

DEMCO[®] Butterfly Valves

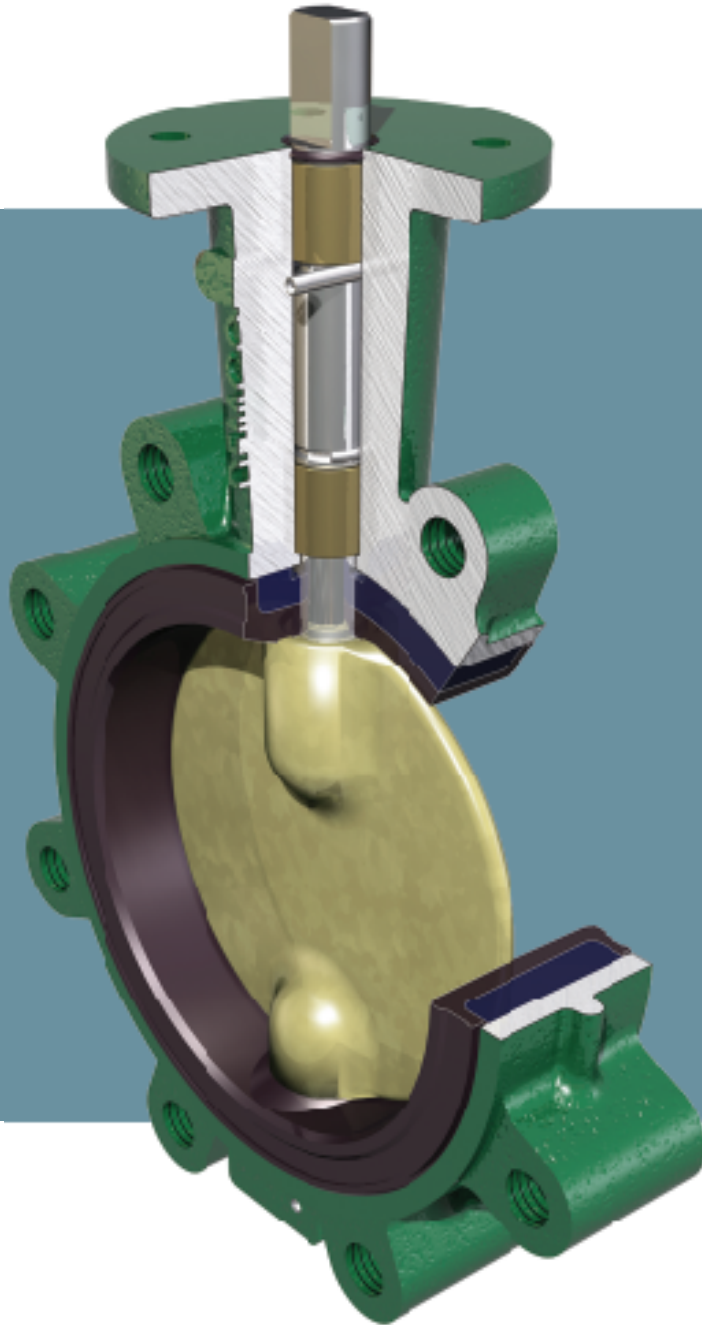

DEMCO[®]

TABLE OF CONTENTS

DEMCO BUTTERFLY VALVES

Features and Benefits	1
Styles and Accessories	3

PRODUCT SPECIFICATIONS

How to Order Valves	5
Base Numbers and Weights	8
Marine Series	9
Component Parts List	10
Dimensional Data (Valves)	12

**HOW TO ORDER
AND TECHNICAL INFORMATION**

Handles	18
Worm Gear Operators	19
Stem Extensions	21
General Technical Information	22
Torque Data	26
Standard Material Data	27

MATERIAL SELECTION GUIDE	28
---------------------------------------	----

TRADEMARK INFORMATION	32
------------------------------------	----

BUTTERFLY VALVES FEATURES AND BENEFITS

One of the most durable of all resilient-seated butterfly valves in the industry, this valve excels in a wide variety of applications.

Cast in both wafer and tapped-lug patterns in a wide variety of material choices, DEMCO Butterfly Valves feature a one-piece body for minimum weight and maximum strength.

The unique stem hole design in the disc ensures a dry stem journal and the hard-backed seat allows ease of installation, reliable operation, and is field-replaceable without special tools. DEMCO Butterfly Valves are available in sizes 2 in. through 36 in. (50 mm through 900 mm).

Engineered for long-term, maintenance-free performance, DEMCO Butterfly Valves are commonly selected for a variety of applications spanning a wide range of industries:

- Chemical and petrochemical
- Agriculture
- Oil and gas drilling and production
- Food and beverage
- Water and waste water
- Cooling towers (HVAC)
- Power
- Mining and materials
- Dry bulk handling
- Marine and government

Bi-directional sealing

This valve provides bi-directional sealing at full rated pressure with identical flow from either direction.

Integral flange seal

Molded into the edge of the seat is an integral flange seal which accommodates ASME weld neck, slip-on, threaded and socket flanges as well as "stub end" type C flanges.

ASME Class 150 rating

Body rating is ASME Class 150 (285 psi non-shock). Wafer body diameters are designed to self-center in ASME Class 150 flange patterns.

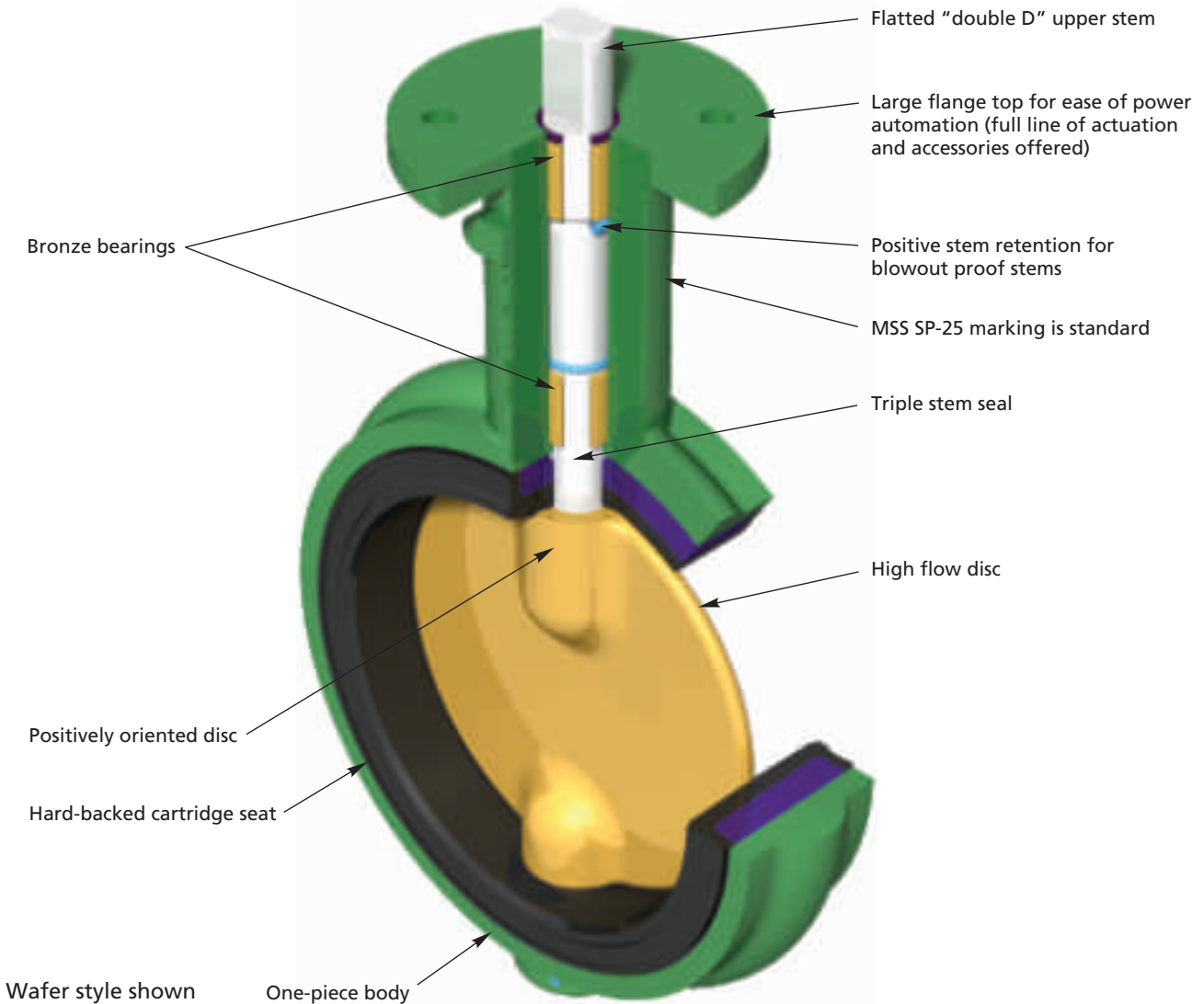

BUTTERFLY VALVES FEATURES AND BENEFITS

Multiple pressure ratings

Three drop tight pressure ratings are offered for 2 in. to 12 in. (50 mm to 300 mm) sizes.

The standard shut-off pressure rating is 200 psi, but 285 and 50 psi shut-off ratings are also available and where drop-tight closure is not required and minimal torque is desired, a throttling 0 psi rated valve is available.

Both the 50 psi and throttling ratings allow for smaller actuators, which can significantly reduce overall installation cost in automated applications.

The 14 in. to 36 in. (350 mm to 900 mm) size valves are available in 150 and 50 psi drop-tight shut-off ratings as well as throttling.

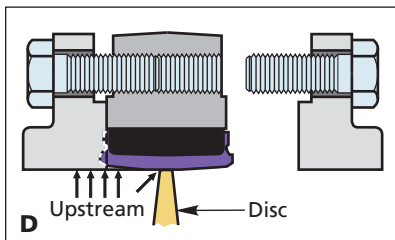
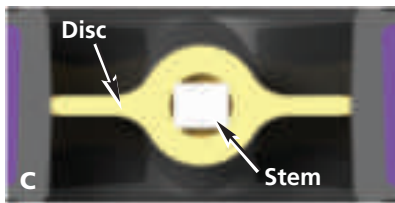
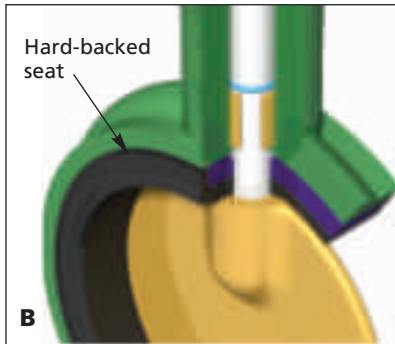
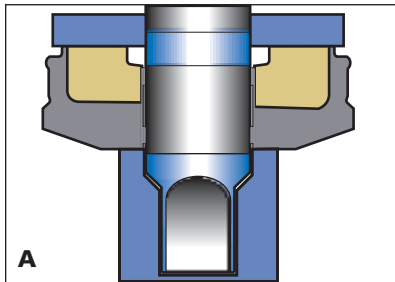

A Dry stem journal eliminates potential for leakage

The DEMCO disc is uniquely designed with a continuous annular raised land around the stem hole and disc edge which presses into the seat flat at every angular position. The resilient seat presses back with a higher specific force than the line pressure, preventing leakage to the stem. In addition, two O-ring ribs are provided in the seat stem bore creating a triple stem seal. In competitive stem seal designs with boot seats, a seal is accomplished by an interference "squeezing" on the stem or an O-ring in the stem journal. The potential for leakage behind the seat is high for this competitive design. As the disc wipes the seat, elongation of the stem seal area allows leakage to collect behind the seat. This condition is eliminated by DEMCO's dry stem journal and hard-backed seat.

B Hard-backed cartridge seat

The DEMCO cartridge seat is constructed by permanently bonding a resilient elastomer to a rigid backing ring. In addition to superior sealing integrity, this design; 1) makes valve installation easier because no special precautions are required for disc position. This is especially advantageous when installing valves with fail closed actuators; 2) eliminates high torque and premature failure caused by elastomer distortion as found in other non-rigid seat designs; 3) simplifies seat replacement because it is slip fitted into the body, with no need for special tools.

C Positively oriented disc

Proper orientation of the stem/disc connection is assured by the rectangular drive. In 2 in. through 24 in. (50 mm through 600 mm) size valves, the disc is permitted to float on the stem to perfectly center in the valve seat. This design enhances drop-tight sealing and prolongs service life.

D End-of-line service

Lug body valves may be used in end-of-line service, with downstream piping removed. (Only weld neck or socket flanges can be used for this service). Since upstream pressure is excluded between the flange and the seat face by the exclusive DEMCO flange seal design, there is no effective force to slide the seat downstream.

DEMCO 2 in. through 12 in. (50 mm through 300 mm) Lug Butterfly Valves are suitable for liquid service up to 200 psi with downstream piping removed (150 psi 14 in. through 36 in.

(350 mm through 900 mm)).

Lug body valves are recommended for isolation of pumps, control devices or other system components which may need to be removed for repair or replacement.

Lug valves are also suitable for installation at points from which piping expansion may proceed. Such valves are normally blanked with blind flanges, to protect the exposed seats until new piping is attached.

SPECIFICATIONS

Sizes

2 in. through 36 in. (50 mm through 900 mm)

Body type and style designations

Long neck NE-C and NF-C:
2 in. through 36 in. (50 mm through 900 mm), wafer / lug, 36 in. (900 mm).

Short neck NE-I, and NE-I Sanitary:
2 in. through 12 in. (50 mm through 300 mm) wafer / lug.

NE-IT Teflon: 2 in. through 10 in. (50 mm through 250 mm) wafer / lug.

NE-D: 2 in. through 12 in. (50 mm through 300 mm) wafer.

Marine: 2 in. through 24 in. (50 mm through 600 mm) wafer / lug.

Pressure rating

2 in. through 12 in. (50 mm through 300 mm):
0 (Throttling), 50, 200 and 285 psi.
2 in. through 10 in. (50 mm through 250 mm)
NEI-T: 150 psi 14 in. through 36 in. (350 mm through 900 mm): 0, 50 and 150 psi.

Operating Temperatures

-30°F to 300°F (-34°C to 204°C) depending on seat material selection and application (see page 27)

Standard Material Options

Bodies: Iron, steel, stainless steel and bronze

Discs: Nickel plated ductile iron, bronze and stainless steel

Stems: 416 and 316 stainless steel

Seats: Buna-N, EPDM, FKM, Neoprene

*Many more options available (see how to order, pages 5, 6, 7 and 27 or consult factory).

BUTTERFLY VALVES STYLES AND ACCESSORIES

This versatile valve comes in a variety of styles to suit an even wider range of applications. In addition, a variety of quality accessories are available to further enhance its suitability to the application.

Series NE-C

Sizes 2 in. through 12 in. (50 mm through 300 mm), this series is a general purpose valve with neck length designed to provide full clearance of the valve top over two inches of insulation on ASME Class 150 pipe flanges; available in both wafer and lug styles.



Series NE-I

Sizes 2 in. through 12 in. (50 mm through 300 mm), it is suited for a wide range of applications in many industries, including food and beverage utilities and process flow lines. This short neck design is offered in a wide variety of body materials. The valves are designed for installation between ASME Class 125/150 flanges.



Series NE-D Valve

Sizes 2 in. through 12 in. (50 mm through 300 mm), it is a short neck valve with body notches to fit popular lightweight flange patterns, making it ideal for bulk material handling and the transportation industry. Valves will also center in ASME Class 125/150 flanges.



Series NF-C

Sizes 14 in. through 36 in. (350 mm through 900 mm) are available in both wafer and lug styles.

The wafer body has two drilled locator lugs at top and bottom for ASME Class 150 flanges. Bronze bearings are installed on both stems for minimum operating torque.



Series NF-C 16 in. (400 mm)



Series NF-C 30 in. (750 mm)

Series NE-I Sanitary

Sizes 2 in. through 12 in. (50 mm through 300 mm), it is similar to our Series NE-I valve, but is exclusively designed to meet the rigorous requirements of sanitary service in the food and beverage industry. The body is available in bronze, stainless steel, aluminum or electroless nickel-coated ductile iron. FDA - approved materials are used for all wetted parts. Handle parts are bronze and stainless steel, permitting caustic washdown.

Other benefits:

- DEMCO dry journal stem seal system gives absolute assurance of sanitary butterfly valve construction.
 - Drilled passageways, a design originated by DEMCO, vent the entire interior of the disc to atmosphere. No closed chamber is provided for the culture of undesirable organisms.
 - Discs are produced from investment castings, smooth and non-porous. Stem bosses are minimized for increased flow.
 - The projecting inner surface of the resilient seat contacts and is compressed by the mating flange to form a smooth and uninterrupted flow way.
- This positive seal between the innermost contact of the seat and flange ensure aseptic conditions after a piping flush.

Sanitary Features

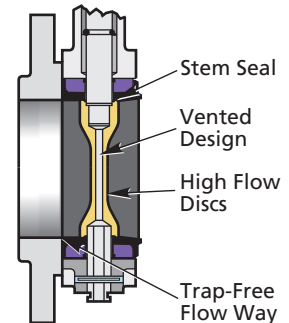

Series NEI-T Teflon

Because of the inert, aseptic non-stick character of Teflon, DEMCO's NEI-T Teflon-lined Butterfly Valve is ideal for "clean" lines in food and beverage plants.

The Teflon seat consists of a virgin Teflon liner overlaying and bonded to an elastomer cushion (either Buna-N or EPDM are available) which provides resilience for sealing.

The Teflon liner extends over the seat faces, completely covering and sealing the resilient material from contact with line fluids.

Marine

DEMCO Marine Butterfly Valves are available in the NE-C Lug, NE-I Lug and Wafer and NE-D Wafer styles and conform to Title 46 of the Code of Federal Regulations, Part 56 of the U.S. Coast Guard's Marine Engineering Regulations as well as the American Bureau of Shipping Standard including tagging per MSS-SP-25 and testing per MSS-SP-67.

BUTTERFLY VALVES STYLES AND ACCESSORIES



A
DEMCO NE-C Wafer

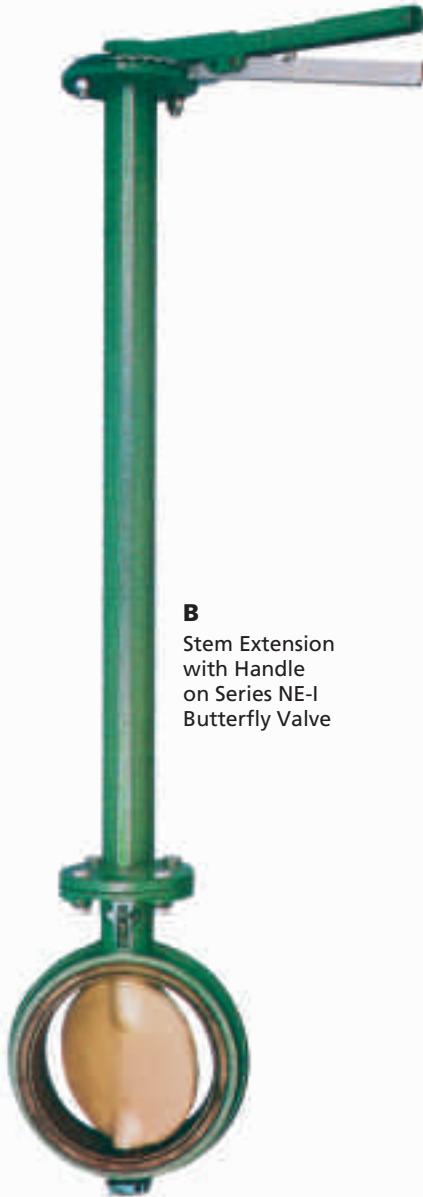

B
Stem Extension
with Handle
on Series NE-I
Butterfly Valve

A
Actuators

Consult Factory for Actuation options.

B
Handles and Stem Extensions

Three basic handle designs interchange on any 2 in. to 12 in. (50 mm to 300 mm) valves: ten position locking, two position locking and memory-stop. Memory-stop handles provide throttling which is infinitely adjustable and can be set by a lock nut with memory-stop setting (adjustable open stop).

Handles are available in basic trim, corrosion-resistant trim and sanitary trim. Stem extensions are fabricated from carbon steel parts and contained in a tubular housing.

Gaskets and O-rings seal the stem extension at top and bottom. These extensions are fabricated to specified lengths.

C
Gear Operators

DEMCO Weatherproof Gear Operators are offered with a choice of handwheel, chain-wheel, or square nut. The worm gearing has self-locking set screws to control open and closed positioning or an optional adjustable memory stop for "balance return" to a preset open position after closing.

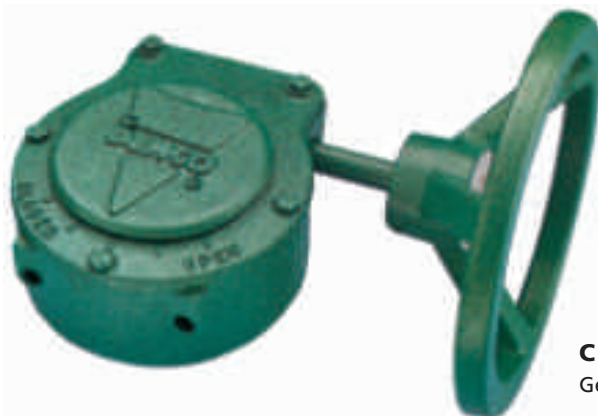

C
Gear Operated

BUTTERFLY VALVES SERIES NE-C, NE-I, NE-D, NEI-T 2 in through 12 in. (50 mm through 300 mm)

Key No.	Qty.	Description	Material
1	1	Body	*
2	1	Seat	*
3	1	Disc	*
4	1	Upper Stem	*
6	1	Lower Stem	*
7	2	Spring Pin	Stainless Steel
14	1	Retainer	Stainless Steel
22	1	Top O-Ring	Buna-N
23	•	Stem O-Ring	Buna-N
24	2	Bearing	Bronze

- * See **How to Order** for material choices/styles.
Complete material specs on page 27.
• 4 required for throttling valves only.

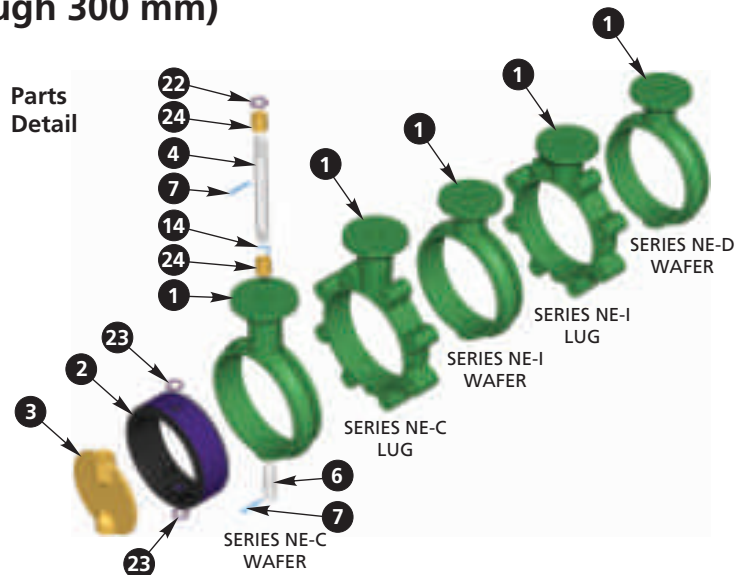

HOW TO ORDER (Example: 6 in. (150 mm) NE-C, 200 psi, Wafer, Standard Trim with Handle 22124-1215311)

X X X X X	-	X	X	X	X	XX	X
Base Part Number		Body Configuration	Body Material*	Stem Material	Disc Material	Seat Elastomer	Actuation
NE-C/NE-I/NEI-T	Wafer	1	NE-C (Longneck)	NE-C, NE-I & NE-D	NE-C, NE-I & NE-D	NE-C, NE-I & NE-D ⁷	Handle
	Lug	5					
NE-D	Wafer	1	Cast Iron (wafer)	316 SS**	Monel ⁶	Black Neoprene	Throttling Mem./Stop
			NE-I & NE-I Sanitary	Monel ⁶	Aluminum Bronze	Hypalon ⁵	Square Nut
			Ductile Iron (NE-I, wafer only)	316 SS Vented***	Ductile Iron Nickel Plated	FKM	2 position Lkg.
			Aluminum Bronze	316 SS Solid***	PVF Coated Ductile Iron ¹	Peroxide Cured EPDM	10 position Sanitary (NEI-T only)
			Carbon Steel (NE-I only)	NEI-Sanitary	Alloy 20 ²	Natural Rubber	None
			Aluminum (NE-I, wafer only)	316 SS***	Hastelloy "C" ⁶	White Neoprene	10 Position Lkg. Corrosion resistant
			ENC Coated Ductile Iron			ETM-30230	2 Position Lkg. Corrosion resistant
			Stainless Steel			Fluorosteam	Throttling/Mem. Stop Corrosion resistant
			NE-D			Peroxide Cured Food Grade EPDM	
			Ductile Iron			Peroxide Cured Buna-N	
			NEI-T			Sulfur Cured Food Grade EPDM	
			Ductile Iron Wafer-Shortneck Lug-Longneck			NEI-T	
			Gray Iron (longneck wafer)			BunaN/Teflon ⁶	
			Aluminum Bronze			Peroxide Cured EPDM/Teflon ⁶	
			Carbon Steel			Sulfur Cured EPDM/Teflon ⁶	
			Aluminum (wafer only)			NEI Sanitary All Seats Food Grade	
			Stainless Steel			Black Neoprene	
						FKM	
						EPDM	
						White Neoprene	
						Sulfur Cured EPDM	

* Standard coating is green enamel; other coatings available on request.

** 17-4 PH SS for 8 in. - 12 in. (200 mm - 300 mm) upper stem only.

*** Except 17-4 PH upper 8 in. & 10 in. (200 mm & 250 mm).

1 200 psi only.

2 Except 285 psi.

3 Polished-ground to #4 dairy finish, Tumbled-vibratory finish to remove "as cast" surface, Unpolished- "as cast" surface.

4 When these options used with NE-I Sanitary butterfly valves, handles will be bronze with SS parts and fasteners.

5 Gear operator recommended for 8 in. - 12 in. (200 mm - 300 mm) sizes in all series.

6 See material trademark note on page 32.

7 Other seat options available (consult factory).

BUTTERFLY VALVES SERIES NF-C

14 in. through 24 in. (350 mm through 600 mm)

Key No.	Qty.	Description	Material
1	1	Body	*
2	1	Seat	*
3	1	Disc	*
4	1	Upper Stem	*
6	1	Lower Stem	*
7	2	Spring Pin	Stainless Steel
14	1	Retainer (Spacer) ■	Stainless Steel
22	1	Top O-Ring	Buna-N
23	•	Stem O-Ring	Buna-N
24	2	Bearing	Bronze

- * See **How to Order** for material choices/styles.
 Complete material specs on page 27.
- 4 required for throttling valves only.
 - 14 in. through 20 in. (350 mm through 500 mm) Spacer.

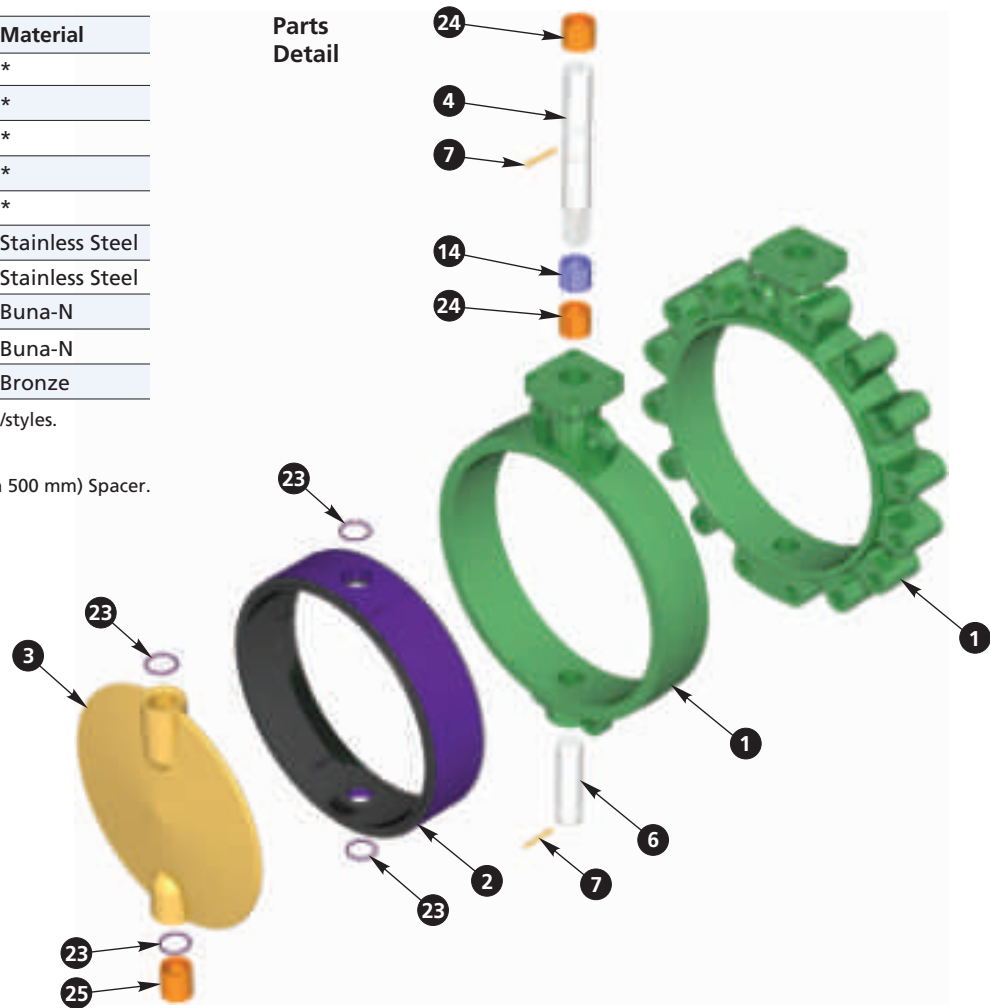

HOW TO ORDER (Example: 18 in. (450 mm) NF-C, 150 psi Lug, SS Trim, Buna-N Seat, WGO. 23822-512231A)

X X X X X		-	X	X	X	X	XX	X																																														
Base Part Number			Body Configuration	Body Material*	Stem Material	Disc Material	Seat Elastomer	Actuation																																														
Wafer	1	<table border="1"> <tr><td>Ductile Iron (lug)</td><td>1</td></tr> <tr><td>Cast Iron (wafer)</td><td>2</td></tr> <tr><td>Aluminum Bronze (lug)</td><td>3</td></tr> <tr><td>Steel (lug)</td><td>4</td></tr> <tr><td>Stainless Steel (lug)</td><td>8</td></tr> </table>	Ductile Iron (lug)	1	Cast Iron (wafer)	2	Aluminum Bronze (lug)	3	Steel (lug)	4	Stainless Steel (lug)	8	<table border="1"> <tr><td>416 SS</td><td>1</td></tr> <tr><td>316 SS</td><td>2</td></tr> <tr><td>Monel²</td><td>3</td></tr> </table>	416 SS	1	316 SS	2	Monel ²	3	<table border="1"> <tr><td>316 SS</td><td>2</td></tr> <tr><td>Monel²</td><td>3</td></tr> <tr><td>Aluminum Bronze</td><td>4</td></tr> <tr><td>Nickel Plated Iron</td><td>5</td></tr> <tr><td>PVF Coated Ductile Iron¹</td><td>6</td></tr> </table>	316 SS	2	Monel ²	3	Aluminum Bronze	4	Nickel Plated Iron	5	PVF Coated Ductile Iron ¹	6	<table border="1"> <tr><td>Buna-N</td><td>31</td></tr> <tr><td>Black Neoprene</td><td>32</td></tr> <tr><td>Hypalon²</td><td>33</td></tr> <tr><td>FKM</td><td>34</td></tr> <tr><td>EPDM</td><td>35</td></tr> </table>	Buna-N	31	Black Neoprene	32	Hypalon ²	33	FKM	34	EPDM	35	<table border="1"> <tr><td>None</td><td>9</td></tr> <tr><td colspan="2">Gear Operators</td></tr> <tr><td>Hand Wheel</td><td>A</td></tr> <tr><td>Chain Wheel</td><td>C</td></tr> <tr><td>Square Nut</td><td>D</td></tr> <tr><td>Bare Shaft</td><td>E</td></tr> </table>	None	9	Gear Operators		Hand Wheel	A	Chain Wheel	C	Square Nut	D	Bare Shaft	E
	Ductile Iron (lug)		1																																																			
Cast Iron (wafer)	2																																																					
Aluminum Bronze (lug)	3																																																					
Steel (lug)	4																																																					
Stainless Steel (lug)	8																																																					
416 SS	1																																																					
316 SS	2																																																					
Monel ²	3																																																					
316 SS	2																																																					
Monel ²	3																																																					
Aluminum Bronze	4																																																					
Nickel Plated Iron	5																																																					
PVF Coated Ductile Iron ¹	6																																																					
Buna-N	31																																																					
Black Neoprene	32																																																					
Hypalon ²	33																																																					
FKM	34																																																					
EPDM	35																																																					
None	9																																																					
Gear Operators																																																						
Hand Wheel	A																																																					
Chain Wheel	C																																																					
Square Nut	D																																																					
Bare Shaft	E																																																					
Lug	5																																																					

Based on shut-off pressure. See page 8

- * Standard coating is green enamel; other coatings available on request.
- 1 150 psi only.
 - 2 See material trademark note on page 32.

BUTTERFLY VALVES SERIES NF-C 30 in. and 36 in. (750 mm and 900 mm)

Key No.	Qty.	Description	Material
1	1	Body	*
2	1	Seat - Hard-Backed	*
3	1	Disc - 150 psi	*
4	1	Upper Stem	*
6	1	Lower Stem	*
7	2	Disc Screw	18-8 SS
8	1	Key	Stainless Steel
9	2	O-Ring	Buna-N
14	1	Spacer	Steel
24	2	Upper Bearing	Bronze
25	1	Lower Bearing	Bronze
26	1	Thrust Collar	Bronze
27	1	Set Screw	18-8 SS
28	1	Cap	Ductile Iron
29	4	Screw	Carbon Steel
30	4	Lockwasher	Carbon Steel

* See **How to Order** for material choices/styles.
Complete material specs on page 27.

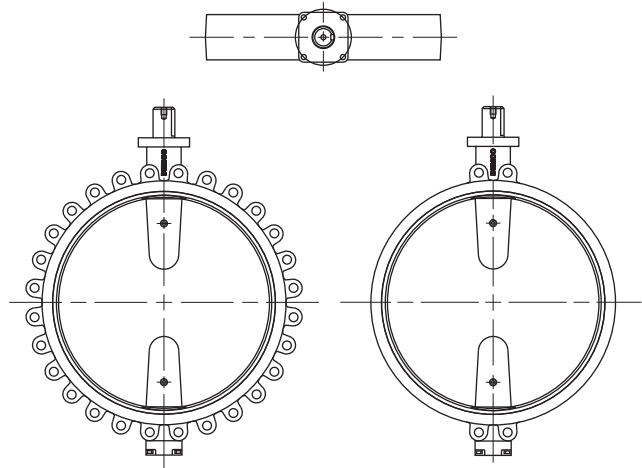

Parts Detail

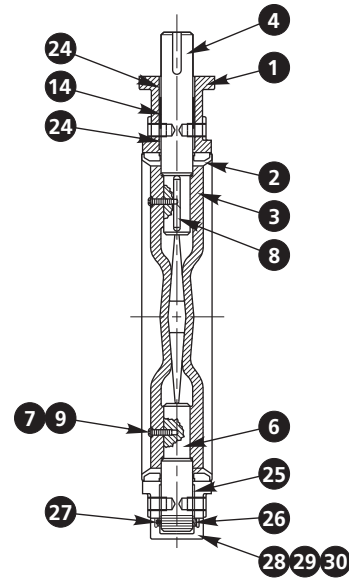

HOW TO ORDER (example: 36 in. (900 mm), 150 psi, Bronze Disc, EPDM Seat with Gear Op 24357-111435A)

XXXXX	-	X	X	X	X	XX	X																																		
Base Part Number		Body Configuration	Body Material*	Stem Material	Disc Material	Seat Elastomer	Actuation																																		
		<table border="1"> <tr> <td>Wafer</td> <td>1</td> </tr> <tr> <td>Lug</td> <td>5</td> </tr> </table>	Wafer	1	Lug	5	<table border="1"> <tr> <td>Ductile Iron (Wafer or Lug)</td> <td>1</td> </tr> </table>	Ductile Iron (Wafer or Lug)	1	<table border="1"> <tr> <td>416 SS</td> <td>1</td> </tr> <tr> <td>316 SS</td> <td>2</td> </tr> <tr> <td>Monel¹</td> <td>3</td> </tr> </table>	416 SS	1	316 SS	2	Monel ¹	3	<table border="1"> <tr> <td>316 SS</td> <td>2</td> </tr> <tr> <td>Monel¹</td> <td>3</td> </tr> <tr> <td>Aluminum Bronze</td> <td>4</td> </tr> <tr> <td>Ductile Iron Nickel Plated</td> <td>5</td> </tr> </table>	316 SS	2	Monel ¹	3	Aluminum Bronze	4	Ductile Iron Nickel Plated	5	<table border="1"> <tr> <td>Buna-N</td> <td>31</td> </tr> <tr> <td>FKM</td> <td>34</td> </tr> <tr> <td>EPDM</td> <td>35</td> </tr> </table>	Buna-N	31	FKM	34	EPDM	35	<table border="1"> <tr> <td>Hand Wheel</td> <td>A</td> </tr> <tr> <td>Chain Wheel</td> <td>C</td> </tr> <tr> <td>Square Nut</td> <td>D</td> </tr> <tr> <td>Bare Stem</td> <td>E</td> </tr> </table>	Hand Wheel	A	Chain Wheel	C	Square Nut	D	Bare Stem	E
Wafer	1																																								
Lug	5																																								
Ductile Iron (Wafer or Lug)	1																																								
416 SS	1																																								
316 SS	2																																								
Monel ¹	3																																								
316 SS	2																																								
Monel ¹	3																																								
Aluminum Bronze	4																																								
Ductile Iron Nickel Plated	5																																								
Buna-N	31																																								
FKM	34																																								
EPDM	35																																								
Hand Wheel	A																																								
Chain Wheel	C																																								
Square Nut	D																																								
Bare Stem	E																																								
<table border="1"> <tr> <td>See page 8</td> </tr> </table>								See page 8																																	
See page 8																																									

* Standard coating is green enamel; other coatings available on request.

¹ See material trademark note on page 32.

BUTTERFLY VALVES BASE PART NUMBERS AND WEIGHTS

SERIES NE-C, 2 in through 12 in. (50 mm through 300 mm)*

Description	in. (mm)	2 (50)	2 1/2 (65)	3 (80)	4 (100)	5 (125)	6 (150)	8 (200)	10 (250)	12 (300)
200 psi		22119	22120	22121	22122	22123	22124	22125	22126	22127
285 psi		22225	22226	22227	22228	22229	22230	22231	22232	22233
50 psi		22234	22235	22236	22237	22238	22239	22240	22241	22242
Throttling		22243	22244	22245	22246	22247	22248	22249	22250	22251
Weight (lbs-bare stem)	Wafer	5.8	7.0	7.7	11.4	14.7	17.6	28.5	47.9	71.0
	Lug	8.0	9.9	10.7	17.0	24.5	28.5	43.5	65.9	98.5

SERIES NE-I, 2 in through 12 in. (50 mm through 300 mm)*

Description	in. (mm)	2 (50)	2 1/2 (65)	3 (80)	4 (100)	5 (125)	6 (150)	8 (200)	10 (250)	12 (300)
200 psi		22128	22129	22130	22131	22132	22133	22134	22135	22136
285 psi		22252	22253	22254	22255	22256	22257	22258	22259	22260
50 psi		22261	22262	22263	22264	22265	22266	22267	22268	22269
Throttling		22270	22271	22272	22273	22274	22275	22276	22277	22278
Weight (lbs-bare stem)	Iron, Steel, SS	4.9	6.4	6.9	10.2	13.7	16.4	28.4	44.8	66.8
	Bronze	4.7	6.2	6.7	9.9	13.4	16.0	28.0	44.3	66.3
Wafer	Aluminum	2.8	3.4	4.1	5.9	8.7	10.8	18.2	30.4	47.2
	Bronze	6.8	8.7	9.5	15.7	23.1	27.0	42.0	64.4	96.8
Lug	Steel, SS	7.0	8.9	9.7	16.0	23.5	27.5	42.5	64.9	97.5

SERIES NE-I, SANITARY, 2 in through 12 in. (50 mm through 300 mm)*

Description	in. (mm)	2 (50)	2 1/2 (65)	3 (80)	4 (100)	6 (150)	8 (200)	10 (250)	12 (300)
200 psi		23150	23151	23152	23153	23154	23155	23156	23157
Weights		See chart above, NE-I, 2 in. - 12 in. (50 mm - 300 mm)							

SERIES NE-D, 2 in through 12 in. (50 mm through 300 mm)*

Description	in. (mm)	2 (50)	2 1/2 (65)	3 (80)	4 (100)	5 (125)	6 (150)	8 (200)	10 (250)	12 (300)
200 psi		22181	22129	25093	22183	22184	22185	22134	22186	22136
285 psi		22279	22253	25135	22281	22282	22283	22258	22284	22260
50 psi		22285	22262	25132	22287	22288	22289	22267	22290	22269
Throttling		22291	22271	25136	22293	22294	22295	22276	22296	22278
Weight (lbs-bare stem) Wafer		4.9	6.4	6.9	10.2	13.7	16.4	28.4	44.8	66.8

SERIES NEI-T, 2 in through 10 in. (50 mm through 250 mm)*

Description	in. (mm)	2 (50)	2 1/2 (65)	3 (80)	4 (100)	6 (150)	8 (200)	10 (250)
150 psi		24680	24681	24682	24683	24684	24685	24686
Weight (lbs-bare stem)	Iron, Steel, SS	4.9	6.4	6.9	10.2	16.4	28.4	44.8
	Bronze	4.7	6.2	6.7	9.9	16.0	28.0	44.3
Wafer**	Aluminum	2.8	3.4	4.1	5.9	10.8	18.2	30.4
	Bronze	6.8	8.7	9.5	15.7	27.0	42.0	64.4
Lug**	Steel, SS	7.0	8.9	9.7	16.0	27.5	42.5	64.9

* Gear Operator recommended for 8 in. through 12 in. (200 mm through 300 mm) sizes.

** See NE-C chart above for weights of Long Neck Wafer and Lug valves.

SERIES NF-C, 14 in through 24 in. (350 mm through 600 mm)

Description	in. (mm)	14 (350)	16 (400)	18 (450)	20 (500)	24 (600)
150 psi		23820	23821	23822	23823	23824
50 psi		24440	24441	24442	24443	24444
Throttling		24445	24446	24447	24448	24449
Weight (lbs-bare stem)	Wafer	102	166	214	257	401
	Lug	116	203	239	332	535

SERIES NF-C

30 in through 36 in. (750 mm through 900 mm)

Description	in. (mm)	30 (750)	36 (900)
150 psi		24141	24357
50 psi		24924	25061
Weights	Wafer	935	1500
	Lug	1050	2020

Marine Valves: Consult factory for data sheets B-255, B-256 and B-258.

DEMCO MARINE BUTTERFLY VALVES

DEMCO Marine Butterfly Valves meet all the requirements of U.S.C.G. Marine Engineering Regulations as outlined in Title 46, Code of Federal Regulations, Part 56 and American Bureau of Shipping including tagging per MSS-SP-25 and testing per MSS-SP-67. All valves are shell tested at 1 1/2 times rated working pressure and seat tested at rated working pressure.

MARINE SERIES, 2 in through 36 in. (50 mm through 900 mm)

Description	in. (mm)	2 (50)	2 1/2 (65)	3 (80)	4 (100)	5 (125)	6 (150)	8 (200)	10 (250)	12 (300)
200 psi		22923	22924	22925	22926	22927	22928	22929	22930	22931
50 psi		22932	22933	22934	22935	22936	22937	22938	22939	22940
285 psi		22914	22915	22916	22917	22918	22919	22920	22921	22922

Weight (lbs-bare stem)
NE-C Long Neck Body

		2 (50)	2 1/2 (65)	3 (80)	4 (100)	5 (125)	6 (150)	8 (200)	10 (250)	12 (300)
Wafer	Gray Iron	5.8	7.0	7.7	11.4	14.7	17.6	28.5	47.9	71.0
Lug	Ductile Iron	8.0	9.9	10.7	17.0	24.5	28.5	43.5	65.9	98.5

NE-I Short Neck Body

		2 (50)	2 1/2 (65)	3 (80)	4 (100)	5 (125)	6 (150)	8 (200)	10 (250)	12 (300)
Wafer	Iron, Steel, SS	4.9	6.4	6.9	10.2	13.7	16.4	28.4	44.8	66.8
	Bronze	4.7	6.2	6.7	9.9	13.4	16.0	28.0	44.3	66.3
Lug	Bronze	6.8	8.7	9.5	15.7	23.1	27.0	42.0	64.4	96.8
	SS, Steel	7.0	8.9	9.7	16.0	23.5	27.5	42.5	64.9	97.5

Description	in. (mm)	14 (350)	16 (400)	18 (450)	20 (500)	24 (600)	30 (750)	36 (900)
150 psi		24611	24612	24613	24614	24615	2227182-	2227183-
50 psi		24653	24654	24655	24656	24657	2227184-	2227185-

Weight (lbs-bare stem)
NF-C Long Neck Body

		14 (350)	16 (400)	18 (450)	20 (500)	24 (600)	30 (750)	36 (900)
Lug	Ductile Iron	116	203	239	332	535	1050	2020
	Bronze	113	199	235	325	525	N/A	N/A

HOW TO ORDER

(Example: 6 in. (150 mm) 200 psi Wafer, Standard Trim with 10 position handle, 22928-1114311)

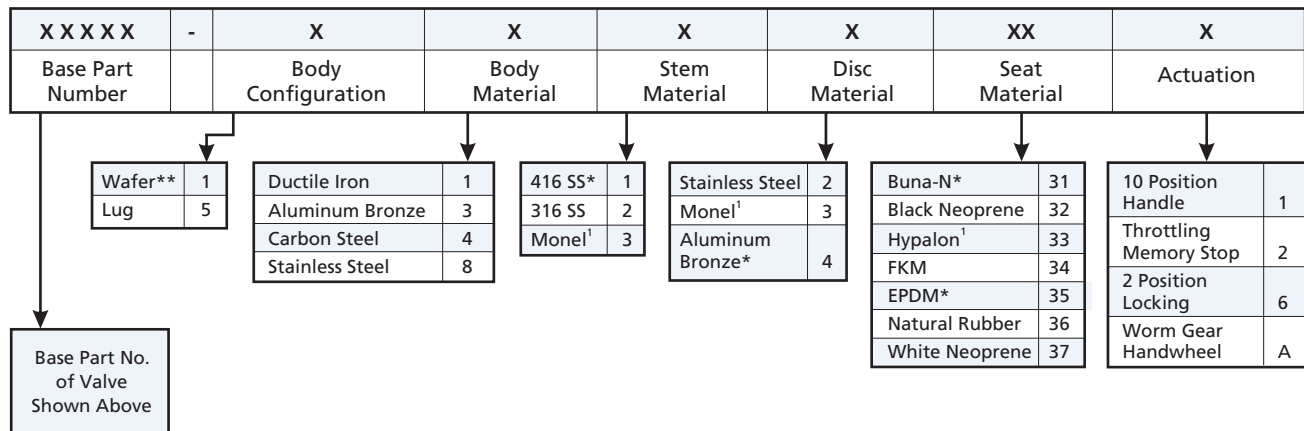

* Standard base trim options.

** Wafer 2 inch through 12 inch only.

Lug 2 inch through 36 inch.

Note: 30 inch and 36 inch available Ductile Iron Lug Body only.

1 See material trademark note on page 32.

BUTTERFLY VALVES COMPONENT PARTS LIST: SERIES NE-C, NE-I, NE-D

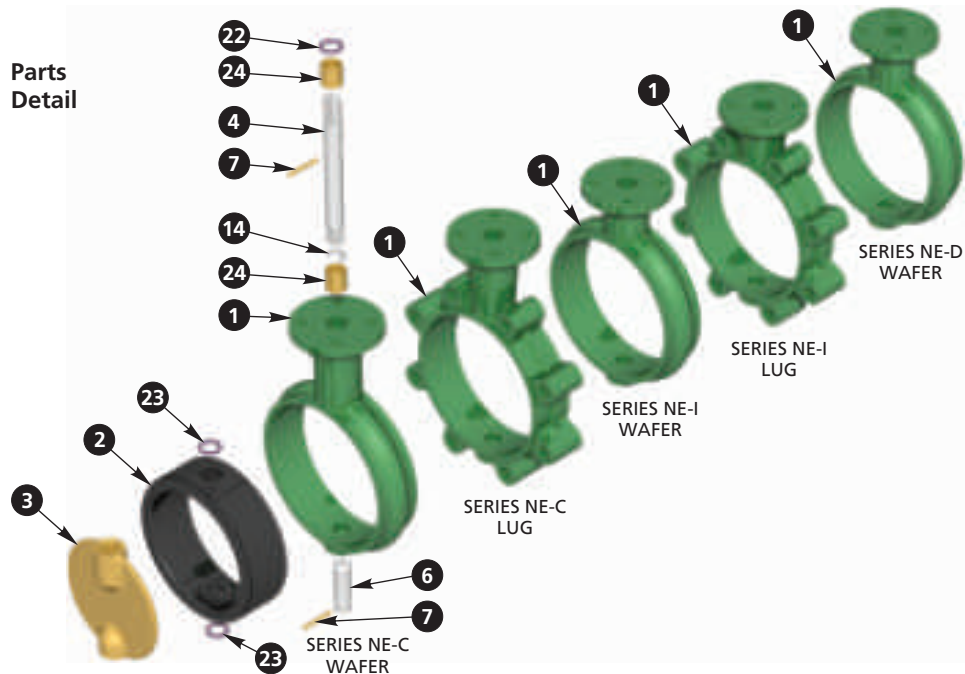

PARTS LIST FOR SERIES NE-C, NE-I & NE-D (replacement parts for NE, NE-S & NE-N, consult factory or company representative).

KEY No.	COMPONENT DESCRIPTION	2 in. (50 mm)	2 1/2 in. (65 mm)	3 in. (80 mm)	4 in. (100 mm)	5 in. (125 mm)	6 in. (150 mm)	8 in. (200 mm)	10 in. (250 mm)	12 in. (300 mm)	
1	BODY	NE-C Wafer	22137-012	22138-012	22139-012	22140-012	22141-012	22142-012	22143-012	22144-012	22145-012
			ASTM A48 Gray Iron -012								
	NE-C Lug	Options	21986-051	21987-051	21988-051	21989-051	21990-051	21991-051	21992-051	21993-051	21994-051
			ASTM A395 Ductile Iron -051								
	NE-I Wafer	Options	22681-01x	22682-01x	22683-01x	22684-01x	22685-01x	22686-01x	22687-01x	22688-01x	22689-01x
			ASTM A395 Ductile Iron -011 , ASTM B148 Aluminum Bronze -013 , ASTM A216 WCB Steel -014 , ASTM B179 Aluminum -015 , DI/ENC -016 , ASTM A351 SS -018								
	NE-I Lug	Options	22695-05x	22696-05x	22697-05x	22698-05x	22699-05x	22700-05x	22701-05x	22702-05x	22703-05x
			ASTM B148 Aluminum Bronze -053 , ASTM A216 WCB Steel -054 , ASTM A351 SS -058								
	NE-D Wafer	Options	22187-021	22682-011	20594-021	22189-021	22190-021	22191-021	22687-011	22192-021	22689-011
			ASTM A395 Ductile Iron -0x1								
2	SEAT	Options	1786-xxx	1788-xxx	1790-xxx ⁶	1792-xxx	1794-xxx	1002-xxx	1798-xxx	1815-xxx	1817-xxx
			Buna-N -031 , Black Neoprene -032 , Hypalon ⁷ -033 , FKM -034 , EPDM ¹ -135 , Nat. Rubber -036 White Neoprene -037 , Peroxide Cured Buna-N -231 , Fluorosteam -244 , ETM-30230 -331								
3	DISC	200 psi	22045-0xx	22046-0xx	22047-0xx	22048-0xx	22049-0xx	22050-0xx	22051-0xx	22052-0xx	22053-0xx
		285 psi	22196-0xx	22197-0xx	22198-0xx	22199-0xx	22200-0xx	22201-0xx	22202-0xx	22203-0xx	22204-0xx
		50 psi	22205-0xx	22206-0xx	22207-0xx	22208-0xx	22209-0xx	22210-0xx	22211-0xx	22212-0xx	22213-0xx
		Throttling	22214-0xx	22215-0xx	22216-0xx	22217-0xx	22218-0xx	22219-0xx	22220-0xx	22221-0xx	22222-0xx
		Options	316 SS -002 , Monel -003 , Nickel Plated Ductile Iron -005 , Alloy 20 ² -007 , Hastelloy C ⁷ -008 , Aluminum Bronze ³ -014								
	PVF Coated 200 psi	22714-001	22715-001	22716-001	22717-001	22718-001	22719-001	22720-001	22721-001	22722-001	
4	UPPER STEM	NE-C	22066-00x	22067-00x	22068-00x	22069-00x	22070-00x	22071-00x	22072-00x	22073-00x	22074-00x
		NE-I	22073-00x	22074-00x	22075-00x	22076-00x	22077-00x	22078-00x	22079-00x	22080-00x	22081-00x
		NE-D	22073-00x	22074-00x	22193-00x	22194-00x	22195-00x	22077-00x	22078-00x	22079-00x	22080-00x
	UPPER STEM -Utility Top	NE-C	22334-00x	22335-00x	22336-00x	22337-00x	22338-00x	22339-00x	22340-00x	22341-00x	22342-00x
		NE-I	22341-00x	22342-00x	22343-00x	22344-00x	22345-00x	22346-00x	22347-00x	22348-00x	22349-00x
6	LOWER STEM	22080-00x	22081-00x	22082-00x	22083-00x	22084-00x	22085-00x	22086-00x	22087-00x	22088-00x	
	Stem Material Options	416 SS -001 , 316 SS ⁴ -002 , Monel ⁷ -003									
7	SPRING PIN (2)	302 SS	5448-18720		5448-18724		5448-25028				
14	RETAINER	Stainless Steel	22117		13704	13705		13706	13707		
22	TOP O-RING	Buna-N	5526-114		5526-115	5526-117		5526-119	5526-125		
23	STEM O-RING ⁵	Buna-N	5526-113	5526-115	5526-116	5526-212		5526-214	5526-220		
24	BEARING (2)	Bronze	22526-001	22118-001	13112-001	13115-001		13116-001	13117-0013		

1 EPDM Seat Options: Standard - Peroxide Cured -135, Food Grade -035 Peroxide Cured, Sulfur Cured -235.
 2 Alloy 20 not available for 285 psi.
 3 8 in. through 12 in. (200 mm through 300 mm), 285 psi Aluminum Bronze, use -024.
 4 8 in. through 12 in. (200 mm through 300 mm), Upper Stem 17-4 PH SS (Part Number suffix -012), Lower Stem 316 SS.
 5 4 required for throttling (0 psi) valves only.
 6 3 in. (80 mm) NE-D Seat Part Number 25095-xxx.
 7 See material trademark note on page 32.

BUTTERFLY VALVES COMPONENT PARTS LIST: SERIES NF-C

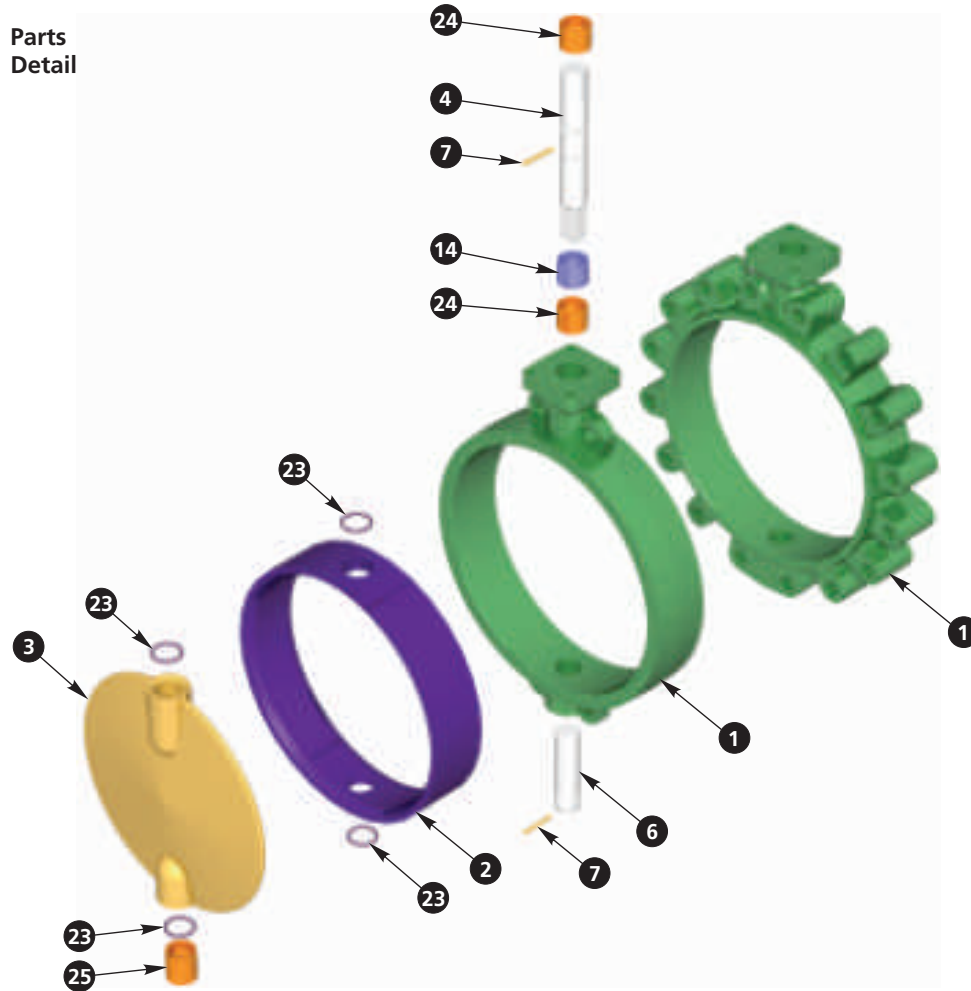
PARTS LIST FOR SERIES NF-C (replacement parts for NF, consult factory or company representative).

KEY No.	QTY.	DESCRIPTION	14 in. (350 mm)	16 in. (400 mm)	18 in. (450 mm)	20 in. (500 mm)	24 in. (600 mm)	Material
1	1	BODY Lug Wafer	23827-051	23911-051	23901-051	23891-051	23875-051	Ductile Iron (Lug) -051
			23825-012	23907-012	23899-012	23881-012	23873-012	Cast Iron (Wafer) -012
2	1	SEAT	23829-03x	23913-03x	23903-03x	23893-03x	7103-03x	Buna-N -031 Blk. Neoprene -032 Hypalon ⁴ -033 FKM -034 EPDM ³ -X35
3	1	DISC -150 psi -50 psi -Throttling -PVF CTD.	23830-0xx	23915-0xx	23905-0xx	23895-0xx	23877-0xx	316 SS -002 Monel ⁴ -003
			24450-0xx	24451-0xx	24452-0xx	24453-0xx	24454-0xx	Aluminum Bronze -014
			24455-0xx	24456-0xx	24457-0xx	24458-0xx	24459-0xx	Ni. Plated Iron -005
			24460-001	24461-001	24462-001	24463-001	24464-001	PVF CTD Iron -001
4	1	UPPER STEM	23833-00x	23917-00x	23897-00x	23897-00x	23879-00x	416 SS -001, 316 SS -002
6	1	LOWER STEM	23834-00x	23918-00x	23898-00x	23898-00x	23880-00x	Monel ⁴ -003
7	2	SPRING PIN	5446-25040	5446-25040	5446-25048	5446-25048	5446-25064	Stainless Steel
14	1	RETAINER (SPACER) ²	5502-137	5502-150	5502-175	5502-175	24470	Steel
23	Note 1	DISC O-RING	5526-220	5526-223	5526-328	5526-328	5526-331	Buna-N
24	2	UPPER BEARING	5086-044	5086-050	5086-048	5086-048	5086-046	Bronze
25	1	LOWER BEARING	5086-045	5086-051	5086-049	5086-049	5086-047	Bronze

1 4 Required, throttling valves only.

2 14 in. through 20 in. (350 mm through 500 mm) Retainer, 24 in. (600 mm) Spacer.

3 EPDM Seat Options: Standard - Peroxide Cured -135, Food Grade -035 Peroxide Cured, Sulfur Cured -235.

4 See material trademark note on page 32.

BUTTERFLY VALVES SERIES NE-C 2 in. through 12 in. (50 mm through 300 mm)

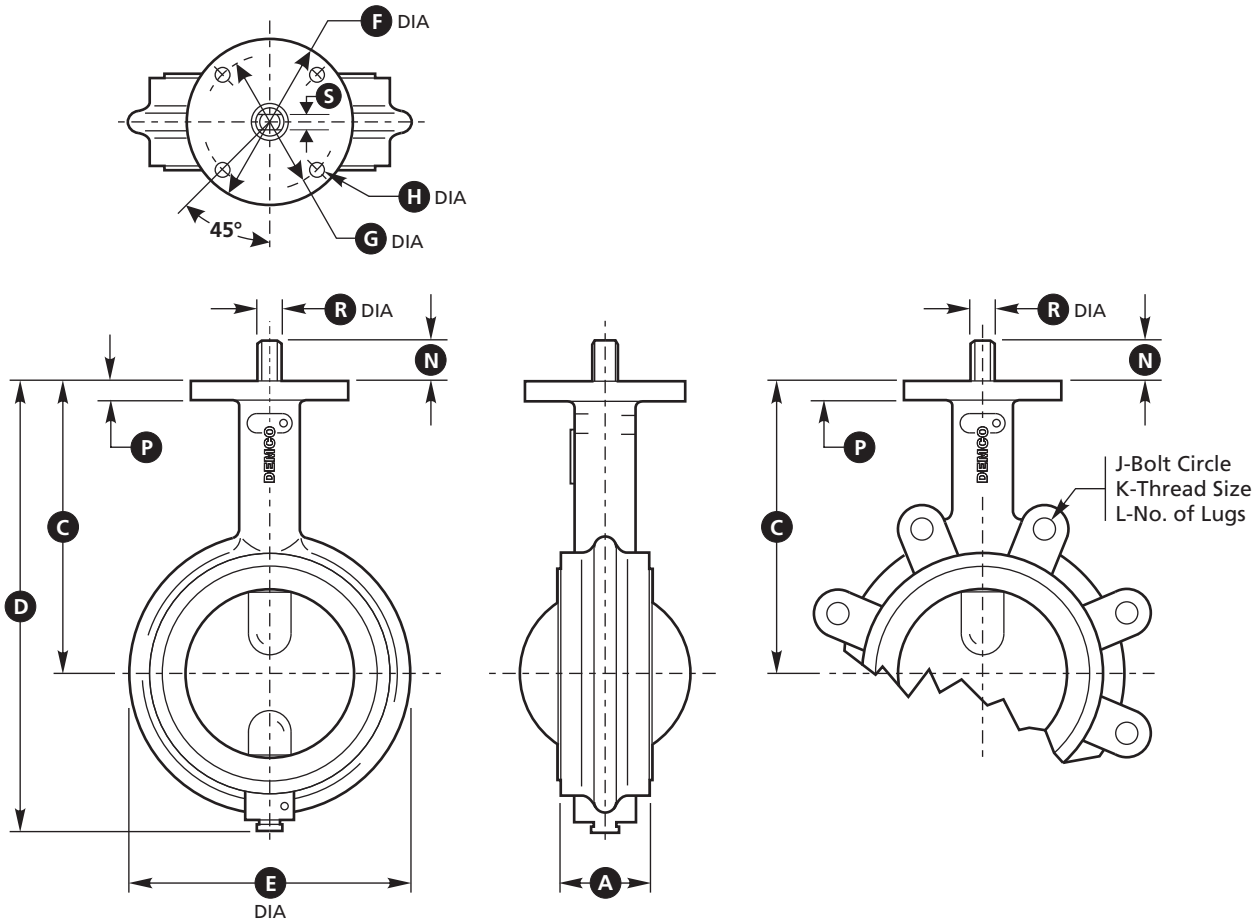

DIMENSIONAL DATA

Size in.	A	C	D	E	F	G	H	J	K	L	N	P	R	S
2	1.74	5.62	8.44	4.12	4.00	3.25	0.408	4.75	5/8-11	4	1.00	0.44	0.625	0.375
2 1/2	1.86	6.12	9.19	4.88	4.00	3.25	0.408	5.50	5/8-11	4	1.00	0.44	0.625	0.375
3	1.86	6.38	9.69	5.38	4.00	3.25	0.408	6.00	5/8-11	4	1.00	0.44	0.625	0.375
4	2.11	7.12	11.00	6.88	4.00	3.25	0.408	7.50	5/8-11	8	1.00	0.44	0.625	0.375
5	2.24	7.75	12.12	7.75	4.00	3.25	0.408	8.50	3/4-10	8	1.25	0.44	0.838	0.500
6	2.24	8.25	13.25	8.75	4.00	3.25	0.408	9.50	3/4-10	8	1.25	0.44	0.838	0.500
8	2.54	9.44	15.56	11.00	6.00	5.00	0.533	11.75	3/4-10	8	1.38	0.56	0.838	0.500
10	2.74	11.25	18.69	13.38	6.00	5.00	0.533	14.25	7/8-9	12	1.38	0.56	0.963	0.625
12	3.24	12.19	21.69	16.12	6.00	5.00	0.533	17.00	7/8-9	12	1.38	0.56	1.338	0.750

Size mm

50	44	143	214	105	102	83	10.36	121	5/8-11	4	25	11.2	15.88	9.53
65	47	155	233	124	102	83	10.36	140	5/8-11	4	25	11.2	15.88	9.53
80	47	162	246	137	102	83	10.36	152	5/8-11	4	25	11.2	15.88	9.53
100	54	181	279	175	102	83	10.36	191	5/8-11	8	25	11.2	15.88	9.53
125	57	197	308	197	102	83	10.36	216	3/4-10	8	32	11.2	21.29	12.70
150	57	210	337	222	102	83	10.36	241	3/4-10	8	32	11.2	21.29	12.70
200	65	240	395	279	152	127	13.54	298	3/4-10	8	35	14.2	21.29	12.70
250	70	286	475	340	152	127	13.54	362	7/8-9	12	35	14.2	24.46	15.88
300	82	310	551	409	152	127	13.54	432	7/8-9	12	35	14.2	33.99	19.05

Note: For general dimensions, see page 24.

BUTTERFLY VALVES SERIES NF-C

14 in. through 24 in. (350 mm through 600 mm)

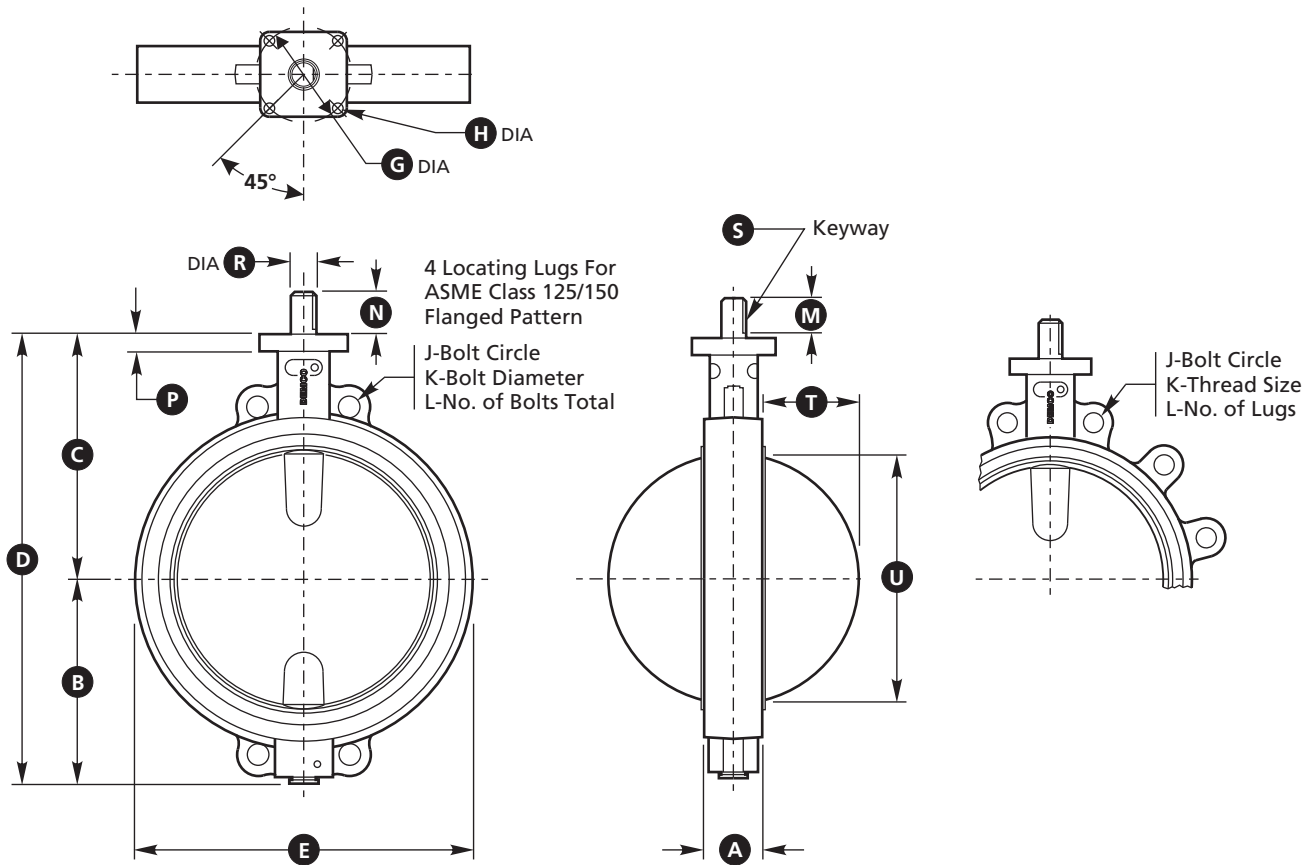

DIMENSIONAL DATA

Size in.	A	B	C	D	E	G	H	J	K	L	M	N	P	R	S	T	U
14	3.00	10.63	12.75	23.4	16.20 17.3*	5.00	0.56	18.75	1-8 1*	12	2.00	2.25	0.88	1.375	5/16 x 5/32	5.12	12.89
16	4.00	11.66	13.75	25.4	18.16 19.2*	5.00	0.56	21.25	1-8 1*	16	2.00	2.25	0.88	1.625	3/8 x 3/16	5.65	14.76
18	4.50	12.96	14.75	27.7	20.35 21.4*	6.50	0.81	22.75	1 1/8-7 1 1/8*	16	2.50	2.75	1.00	1.875	1/2 x 3/16	6.37	16.63
20	5.00	13.97	15.75	29.7	22.63 23.6*	6.50	0.81	25.00	1 1/8-7 1 1/8*	20	2.50	2.75	1.00	1.875	1/2 x 3/16	7.12	18.58
24	6.00	16.19	19.00	35.2	27.31 28.3*	6.50	0.81	29.50	1 1/4-7 1 1/4*	20	2.50	3.00	1.00	1.875	1/2 x 3/16	8.67	22.56
Size mm																	
350	76	270	324	594	411 439*	127	14.2	476	1-8 1*	12	51	57	22.4	34.93	7.94 x 3.97	130	327
400	102	296	349	645	461 488*	127	14.2	540	1-8 1*	16	51	57	22.4	41.28	9.53 x 4.76	144	375
450	114	329	375	704	517 544*	165	20.6	578	1 1/8-7 1 1/8*	16	64	57	25.4	47.63	12.70 x 4.76	162	422
500	127	355	400	754	575 599*	165	20.6	635	1 1/8-7 1 1/8*	20	64	57	25.4	47.63	12.70 x 4.76	181	472
600	152	411	483	894	694 719*	165	20.6	749	1 1/4-7 1 1/4*	20	64	76	25.4	47.63	12.70 x 4.76	220	573

* Wafer valve dimension is the bottom figure. Lug valve dimension is the top figure.
Note: For general dimensions, see page 24.

BUTTERFLY VALVES SERIES NF-C 30 in. through 36 in. (750 mm through 900 mm)

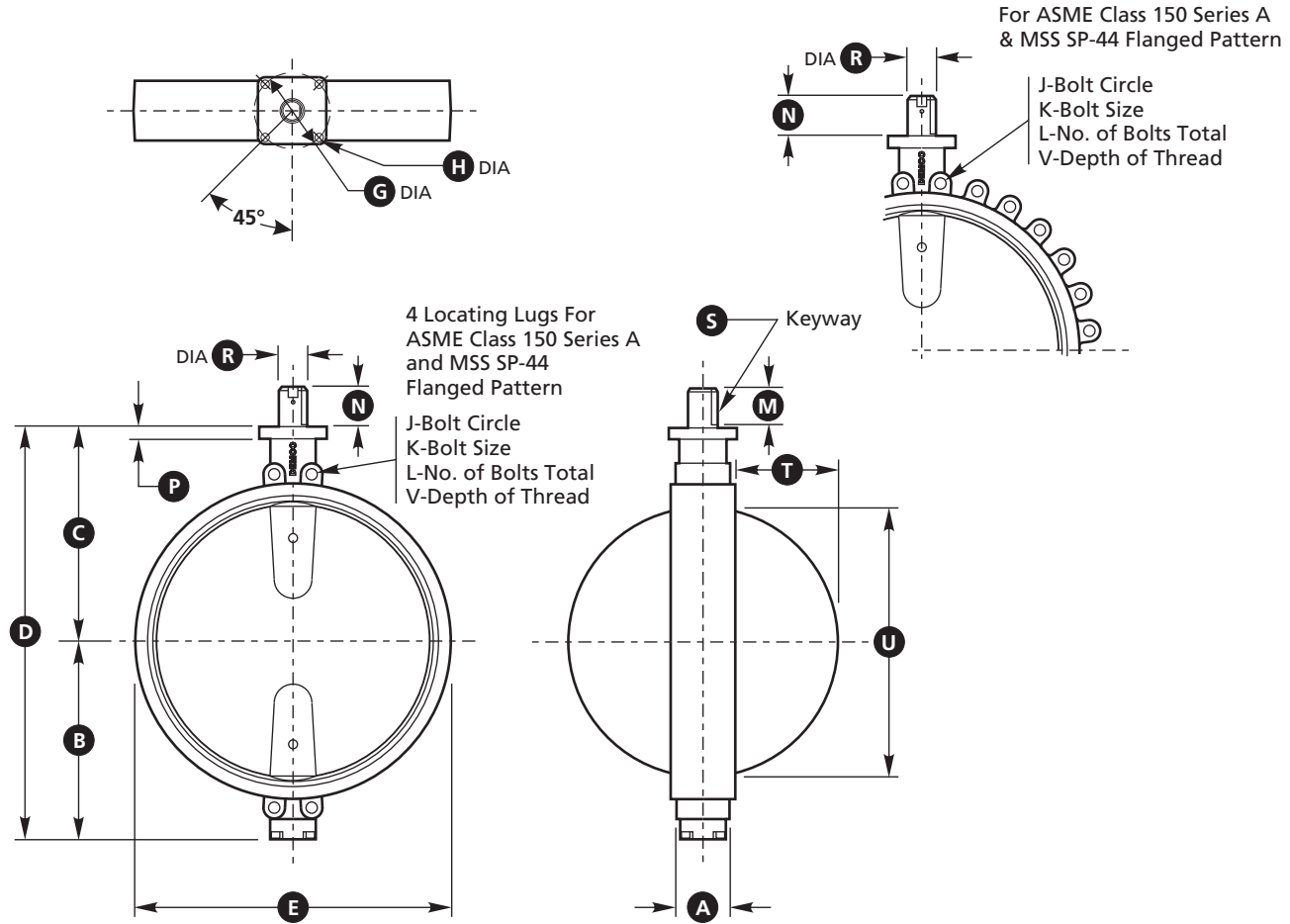

DIMENSIONAL DATA

Size in.	A	B	C	D	E	G	H	J	K	L	M	N	P	R	S	T	U	V
30	6.50	21.2	23.0	44.2	34.1	8.00	0.69	36.00	1 1/4-7UNC	28	3.4	3.7	1.2	3.000	3/4 x 3/8	11.45	28.55	1.750
36	7.88	25.0	27.8	52.8	40.5	10.25	0.81	42.75	1 1/2-6UNC	32	4.0	4.4	1.5	3.625	7/8 x 7/16	13.86	34.71	1.750
Size mm																		
750	165	538	584	1123	866	203	17.53	914	1 1/4-7UNC	28	86	94	30.5	76.2	19.05 x 9.53	291	725	44.45
900	200	635	706	1342	1029	260	20.57	1086	1 1/2-6UNC	32	102	112	38.1	92.1	22.23 x 11.11	352	882	44.45

Note: For general dimensions, see page 24.

BUTTERFLY VALVES SERIES NE-D

2 in. through 12 in. (50 mm through 300 mm)

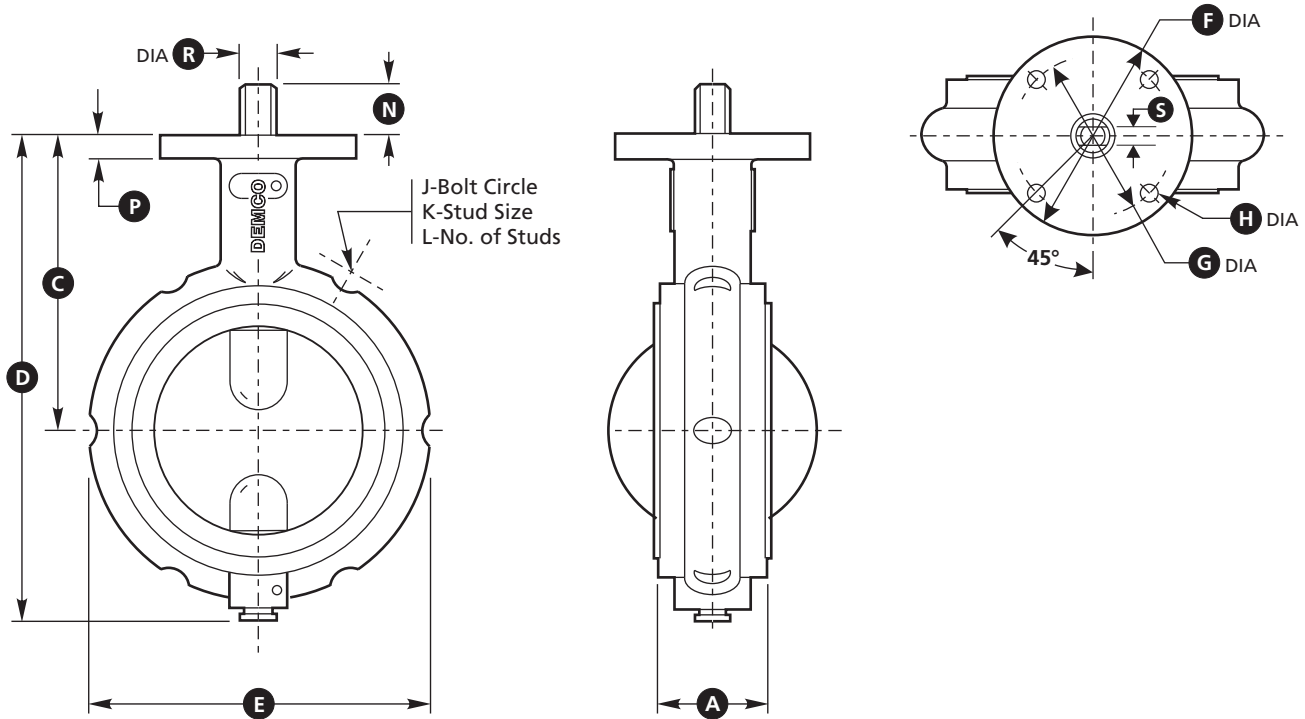

DIMENSIONAL DATA

Size in.	A	C	D	E	F	G	H	J	K	L	N	P	R	S
2	1.74	3.94	6.75	4.12	4.00	3.25	0.408	4.27	3/8	4	1.00	0.44	0.625	0.375
2 1/2	1.86	4.44	7.50	4.88	4.00	3.25	0.408	5.31	3/8	4	1.00	0.44	0.625	0.375
3	1.86	4.88	8.19	5.38	4.00	3.25	0.408	4.91	3/8	6	1.00	0.44	0.625	0.375
4	2.11	6.00	9.88	6.88	4.00	3.25	0.408	7.03	1/2	6	1.00	0.44	0.625	0.375
5	2.24	6.00	10.38	7.75	4.00	3.25	0.408	7.56	1/2	6	1.25	0.44	0.838	0.500
6	2.24	6.50	11.50	8.75	4.00	3.25	0.408	9.16	1/2	8	1.25	0.44	0.838	0.500
8	2.54	8.06	14.19	11.00	6.00	5.00	0.533	11.72	5/8	8	1.38	0.56	0.838	0.500
10	2.74	9.97	17.41	13.38	6.00	5.00	0.533	13.72	5/8	8	1.38	0.56	0.963	0.625
12	3.24	10.91	20.41	16.12	6.00	5.00	0.533	16.62	1/2	12	1.38	0.56	1.338	0.750
Size mm														
50	44	100	171	105	102	83	10.36	108	10	4	25	11.2	15.88	9.53
65	47	113	191	124	102	83	10.36	135	10	4	25	11.2	15.88	9.53
80	47	124	208	137	102	83	10.36	125	10	6	25	11.2	15.88	9.53
100	54	152	251	175	102	83	10.36	179	15	6	25	11.2	15.88	9.53
125	57	152	264	197	102	83	10.36	192	15	6	32	11.2	21.29	12.70
150	57	165	292	222	102	83	10.36	233	15	8	32	11.2	21.29	12.70
200	65	205	360	279	152	127	13.54	298	16	8	35	14.2	21.29	12.70
250	70	253	442	340	152	127	13.54	348	16	8	35	14.2	24.46	15.88
300	82	277	518	409	152	127	13.54	422	15	12	35	14.2	33.99	19.05

Note: For general dimensions, see page 24.

BUTTERFLY VALVES SERIES NE-I, NE-I SANITARY 2 in. through 12 in. (50 mm through 300 mm)

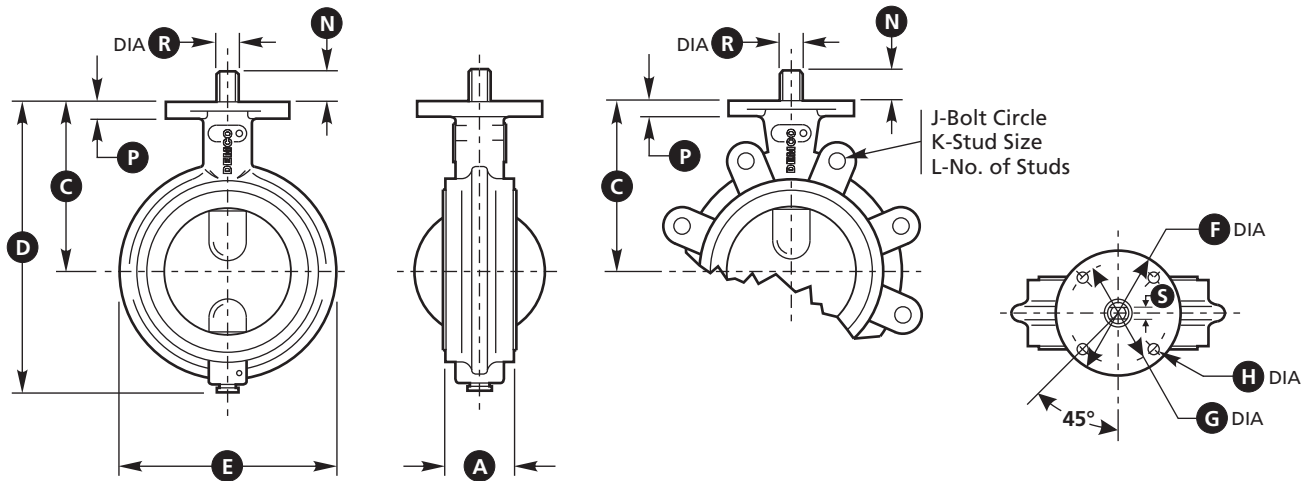

DIMENSIONAL DATA

Size in.	A	C	D	E	F	G	H	J	K	L	N	P	R	S
2	1.74	3.94	6.75	4.12	4.00	3.25	0.408	4.75	5/8-11	4	1.00	0.44	0.625	0.375
2 1/2	1.86	4.44	7.50	4.88	4.00	3.25	0.408	5.50	5/8-11	4	1.00	0.44	0.625	0.375
3	1.86	4.69	8.00	5.38	4.00	3.25	0.408	6.00	5/8-11	4	1.00	0.44	0.625	0.375
4	2.11	5.44	9.31	6.88	4.00	3.25	0.408	7.50	5/8-11	8	1.00	0.44	0.625	0.375
5*	2.24	6.38	10.75	7.75	4.00	3.25	0.408	8.50	3/4-10	8	1.25	0.44	0.838	0.500
6	2.24	6.88	11.88	8.75	4.00	3.25	0.408	9.50	3/4-10	8	1.25	0.44	0.838	0.500
8	2.54	8.06	14.19	11.00	6.00	5.00	0.533	11.75	3/4-10	8	1.38	0.56	0.838	0.500
10	2.74	9.97	17.41	13.38	6.00	5.00	0.533	14.25	7/8-9	12	1.38	0.56	0.963	0.625
12	3.24	10.91	20.41	16.12	6.00	5.00	0.533	17.00	7/8-9	12	1.38	0.56	1.338	0.750

Size mm

50	44	100	171	105	102	83	10.36	121	5/8-11	4	25	11.2	15.88	9.53
65	47	113	191	124	102	83	10.36	140	5/8-11	4	25	11.2	15.88	9.53
80	47	119	203	137	102	83	10.36	152	5/8-11	6	25	11.2	15.88	9.53
100	54	138	236	175	102	83	10.36	191	5/8-11	6	25	11.2	15.88	9.53
125*	57	162	273	197	102	83	10.36	216	3/4-10	6	32	11.2	21.29	12.70
150	57	175	302	222	102	83	10.36	241	3/4-10	8	32	11.2	21.29	12.70
200	65	205	360	279	152	127	13.54	298	3/4-10	8	35	14.2	21.29	12.70
250	70	253	442	340	152	127	13.54	362	7/8-9	8	35	14.2	24.46	15.88
300	82	277	518	409	152	127	13.54	432	7/8-9	12	35	14.2	33.99	19.05

* NE-I Sanitary 5 in. (125 mm) not available.

Note: For general dimensions, see page 24.

BUTTERFLY VALVES SERIES NEI-T

2 in. through 10 in. (50 mm through 250 mm)

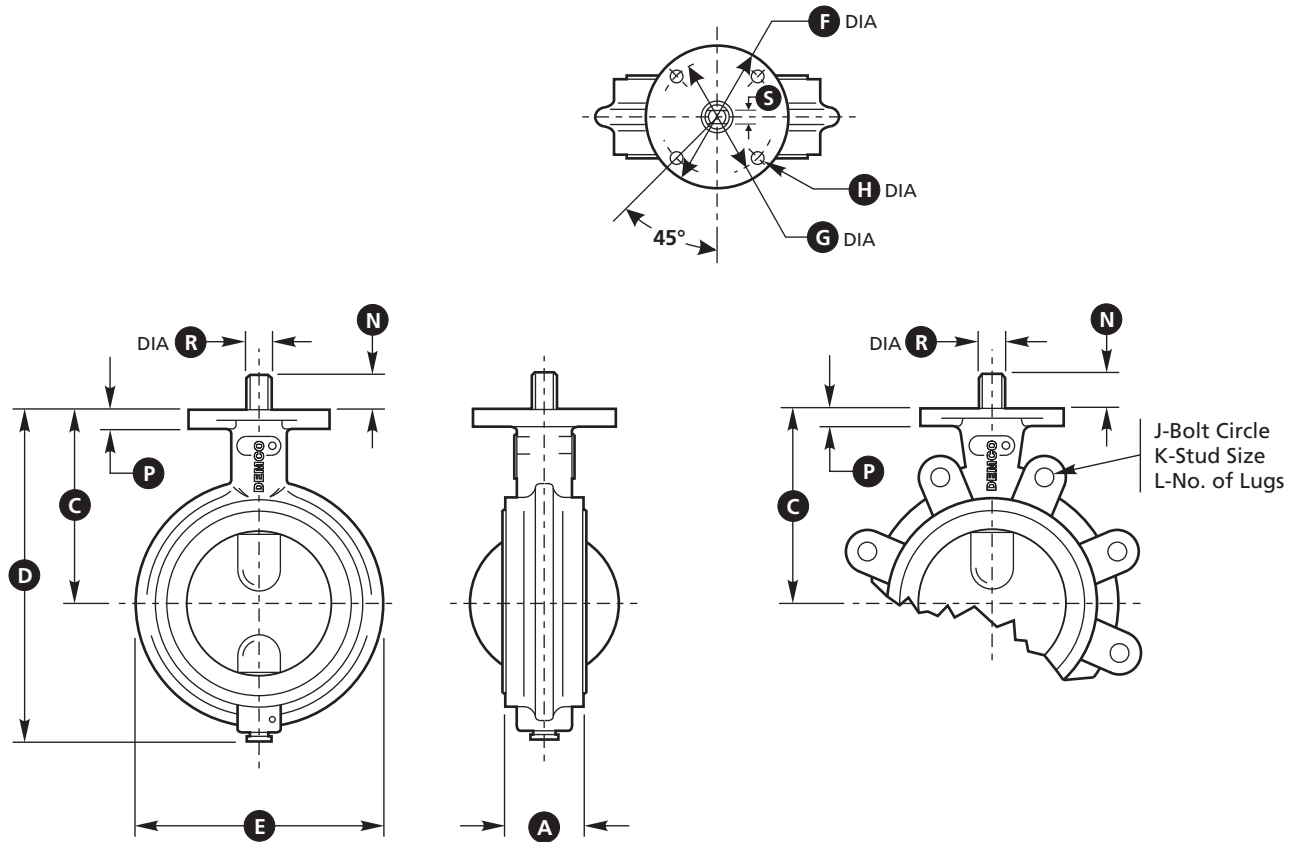

DIMENSIONAL DATA

Size in.	A	C	D	E	F	G	H	J	K	L	N	P	R	S
2	1.74	3.94	6.75	4.12	4.00	3.25	0.408	4.75	5/8-11	4	1.00	0.44	0.625	0.375
2 1/2	1.86	4.44	7.50	4.88	4.00	3.25	0.408	5.50	5/8-11	4	1.00	0.44	0.625	0.375
3	1.86	4.69	8.00	5.38	4.00	3.25	0.408	6.00	5/8-11	4	1.00	0.44	0.625	0.375
4	2.11	5.44	9.31	6.88	4.00	3.25	0.408	7.50	5/8-11	8	1.00	0.44	0.625	0.375
6	2.24	6.88	11.88	8.75	4.00	3.25	0.408	9.50	3/4-10	8	1.25	0.44	0.838	0.500
8	2.54	8.06	14.19	11.00	6.00	5.00	0.533	11.75	3/4-10	8	1.38	0.56	0.838	0.500
10	2.74	9.97	17.41	13.38	6.00	5.00	0.533	14.25	7/8-9	12	1.38	0.56	0.963	0.625
Size mm														
50	44	100	171	105	102	83	10.36	121	5/8-11	4	25	11.2	15.88	9.53
65	47	113	191	124	102	83	10.36	140	5/8-11	4	25	11.2	15.88	9.53
80	47	119	203	137	102	83	10.36	152	5/8-11	6	25	11.2	15.88	9.53
100	54	138	236	175	102	83	10.36	191	5/8-11	6	25	11.2	15.88	9.53
150	57	175	302	222	102	83	10.36	241	3/4-10	8	32	11.2	21.29	12.70
200	65	205	360	279	152	127	13.54	298	3/4-10	8	35	14.2	21.29	12.70
250	70	253	442	340	152	127	13.54	362	7/8-10	8	35	14.2	24.46	15.88

Note: For general dimensions, see page 24.

BUTTERFLY VALVES - HANDLES

HOW TO ORDER

How to Order (X X X X X - 0 0 X)

X X X X X	-	00X
Base Part Number		Trim

Standard	1
Corrosive Resistant	2
Sanitary	3

Description	in. (mm)	2 to 4 (50 to 100)	5 to 6 (125 to 150)	8 (200)	10 (250)	12 (300)
10 Position, Standard, CR	24227	24228	24229	24230	24231	
2 Position, Standard, CR	24232	24233	24234	24235	24236	
10 Position, Sanitary	22319	22320	22321	22322	22323	
2 Position, Sanitary	22324	22325	22326	22327	22328	
Throttling, Standard, CR	24252	24253	24254	24255	24256	
Throttling, Sanitary	22329	22330	22331	22332	22333	
Square Nut, Standard	23356	23357	23358	23359	22360	
Weight (lbs.)	2.3	2.9	6.5	6.5	6.5	

2 Position/10 Position Locking Handles

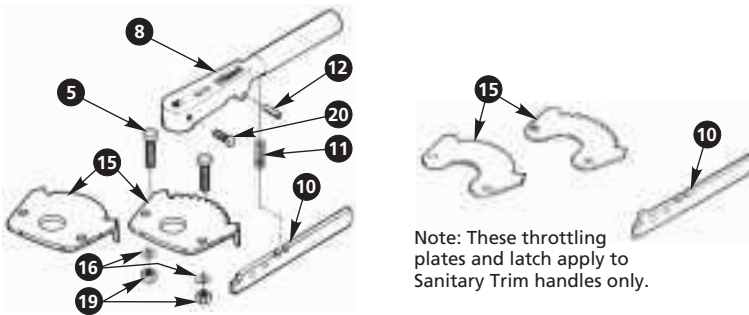

Key No.	Description	Material		
		Standard	Corrosion Resistant	Sanitary
5	Screw	Steel	Stainless Steel	Stainless Steel
8	Handle	Ductile Iron	Ductile Iron	Bronze
10	Latch	Zinc Plated Steel	Stainless Steel	Stainless Steel
11	Spring	Spring Steel	Stainless Steel	Stainless Steel
12	Spring Pin	Spring Steel	Stainless Steel	Stainless Steel
15	Throttle Plate	Zinc Plated Steel	Stainless Steel	Stainless Steel
16	Lockwasher	Steel	Stainless Steel	Stainless Steel
19	Nut	Steel	Stainless Steel	Stainless Steel
20	Set Screw	Steel	Stainless Steel	Stainless Steel
25*	Throttling Tab	Zinc Plated Steel	Stainless Steel	Stainless Steel
26*	Carriage Bolt	Steel	Stainless Steel	Stainless Steel
27*	Wing Nut	Steel	Stainless Steel	Stainless Steel
28*	Screw	Steel	Stainless Steel	Stainless Steel
29*	Nut	Steel	Stainless Steel	Stainless Steel

* For Throttling memory Stop Handle only.

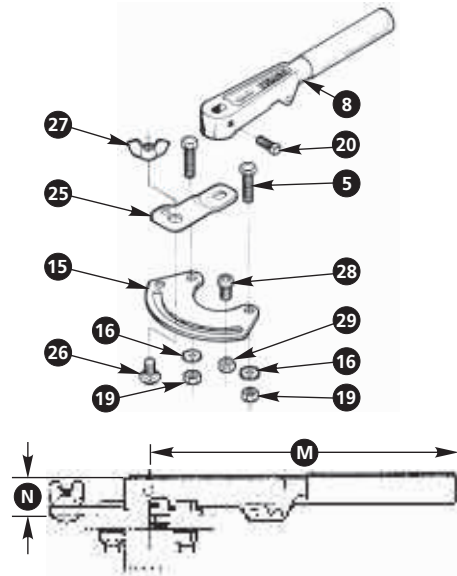

Infinite Throttling with Memory Stop Handle

Dimension (mm)	in. (50 to 100)	2 to 4 (125 to 150)	5 to 6 (200 to 300)	8 to 12 (381)
M	9.50 (241)	11.00 (279)	15.00 (381)	
N	0.85 (21.6)	1.07 (27.2)	1.13 (28.7)	

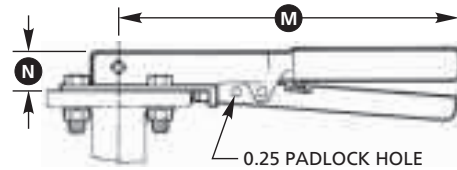

2 Position/10 Position Locking Handles

Dimension (mm)	in. (50 to 100)	2 to 4 (125 to 150)	5 to 6 (200 to 300)	8 to 12 (381)
M	9.50 (241)	11.00 (279)	15.00 (381)	
N	0.87 (22.1)	1.07 (27.2)	1.13 (28.7)	

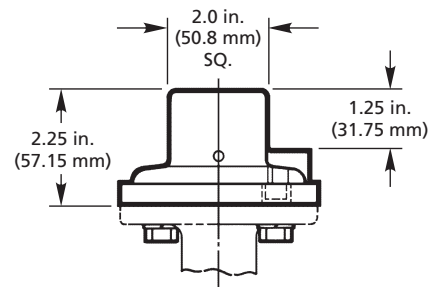

Square Nut Handle

Description	Material
Square Nut Hub	Ductile Iron
Throttle Plate	Steel
Screw	Steel
Set Screw	Steel
Screw	Steel
Lock Washer	Spring Steel

BUTTERFLY VALVES WORM GEAR OPERATORS

Manual worm gear operators are self locking in all positions. Adjustment screws stop travel at open and closed positions. Position indicator is standard on all models. Gearing is permanently lubricated.

Gray iron weatherproof case and cover enclose a ductile iron gear and hardened steel worm supported by bronze bearings. Standard external coating is green enamel; white epoxy, coal tar epoxy and inorganic zinc primer available, special order.

HOW TO ORDER

2 in. through 12 in. (50 mm through 300 mm) (Example: 6 in. (150 mm) with Handwheel 22622-21352)

XXXXXX	-	X	X	X	X	X																				
Base Part Number		Case Material	Gear Material	Actuation	Valve Size	Configuration																				
		Gray Iron 2	Ductile Iron 1	<table border="1"> <tr><td>Crank</td><td>1</td></tr> <tr><td>Hand Wheel</td><td>3</td></tr> <tr><td>Chain Wheel</td><td>5</td></tr> <tr><td>Square Nut</td><td>6</td></tr> <tr><td>None</td><td>9</td></tr> </table>	Crank	1	Hand Wheel	3	Chain Wheel	5	Square Nut	6	None	9	<table border="1"> <tr><td>2 in. to 4 in. (50 mm to 100 mm)</td><td>1</td></tr> <tr><td>5 in. & 6 in. (125 mm & 150 mm)</td><td>5</td></tr> <tr><td>8 in. (200 mm)</td><td>7</td></tr> <tr><td>10 in. (250 mm)</td><td>8</td></tr> <tr><td>12 in. (300 mm)</td><td>9</td></tr> </table>	2 in. to 4 in. (50 mm to 100 mm)	1	5 in. & 6 in. (125 mm & 150 mm)	5	8 in. (200 mm)	7	10 in. (250 mm)	8	12 in. (300 mm)	9	Standard 2
Crank	1																									
Hand Wheel	3																									
Chain Wheel	5																									
Square Nut	6																									
None	9																									
2 in. to 4 in. (50 mm to 100 mm)	1																									
5 in. & 6 in. (125 mm & 150 mm)	5																									
8 in. (200 mm)	7																									
10 in. (250 mm)	8																									
12 in. (300 mm)	9																									
Description		2 in. to 4 in. (50 mm to 500 mm)	5 in. to 6 in. (125 mm to 150 mm)	8 in. (200 mm)	10 in. (250 mm)	12 in. (300 mm)																				
Operator Base No.		22622	22622	22623	22623	22623																				
Additional Information																										
Chain Suffix = Length in Ft.*		4462-XXX	4462-XXX	4462-XXX	4462-XXX	4462-XXX																				
Weight (lb. (kg) with handwheel)		7.8 (3.5)	7.8 (3.5)	17.2 (7.8)	17.2 (7.8)	18.6 (8.4)																				

HOW TO ORDER

14 in. through 36 in. (350 mm through 900 mm)

XXXXXXXX	-	XX								
Base Part Number		Gear Operator Assembly Part Number								
		<table border="1"> <tr><td>Gear Operator Less Actuation</td><td>09</td></tr> <tr><td>Gear Operator With Handwheel</td><td>03</td></tr> <tr><td>Gear Operator With Chainwheel</td><td>05</td></tr> <tr><td>Gear Operator With Square Nut</td><td>06</td></tr> </table>	Gear Operator Less Actuation	09	Gear Operator With Handwheel	03	Gear Operator With Chainwheel	05	Gear Operator With Square Nut	06
Gear Operator Less Actuation	09									
Gear Operator With Handwheel	03									
Gear Operator With Chainwheel	05									
Gear Operator With Square Nut	06									
Description		14 in. (350 mm)	16 in. (400 mm)	18 in. to 20 in. (450 mm to 500 mm)	24 in. (600 mm)	30 in. (750 mm)	36 in. (900 mm)			
Operator Base No.		2060229	2060230	2060231	2060232	2060332	2060334			
Additional Information										
Chain Suffix = Length in Ft.*		4462-XXX	4463-XXX	4463-XXX	19932-XXX	4463-XXX	19932-XXX			
Weight (lb. (kg) with handwheel)		19.0 (8.6)	22.0 (10.0)	33.0 (15.0)	43.0 (19.5)	107.0 (48.5)	137.0 (62.1)			

Valve Size	in.	(mm)	Gear Ratio	Turns/90° Rotation	Maximum Input Torque
	2 to 6	(50 to 150)	30:1	7 1/2	46 ft.-lbs.
	8 to 12	(200 to 300)	48:1	12	65 ft.-lbs.
	14 to 16	(350 to 400)	48:1	12	65 ft.-lbs.
	18 to 20	(450 to 500)	57:1	14 1/4	98 ft.-lbs.
	24	(600)	60:1	15	164 ft.-lbs.
	30	(750)	316:1	79	104 ft.-lbs.
	36	(900)	240:1	60	174 ft.-lbs.

* Chain Length (xxx) = 000 through 999 ft. (Chain ordered separately).

BUTTERFLY VALVES WORM GEAR OPERATORS

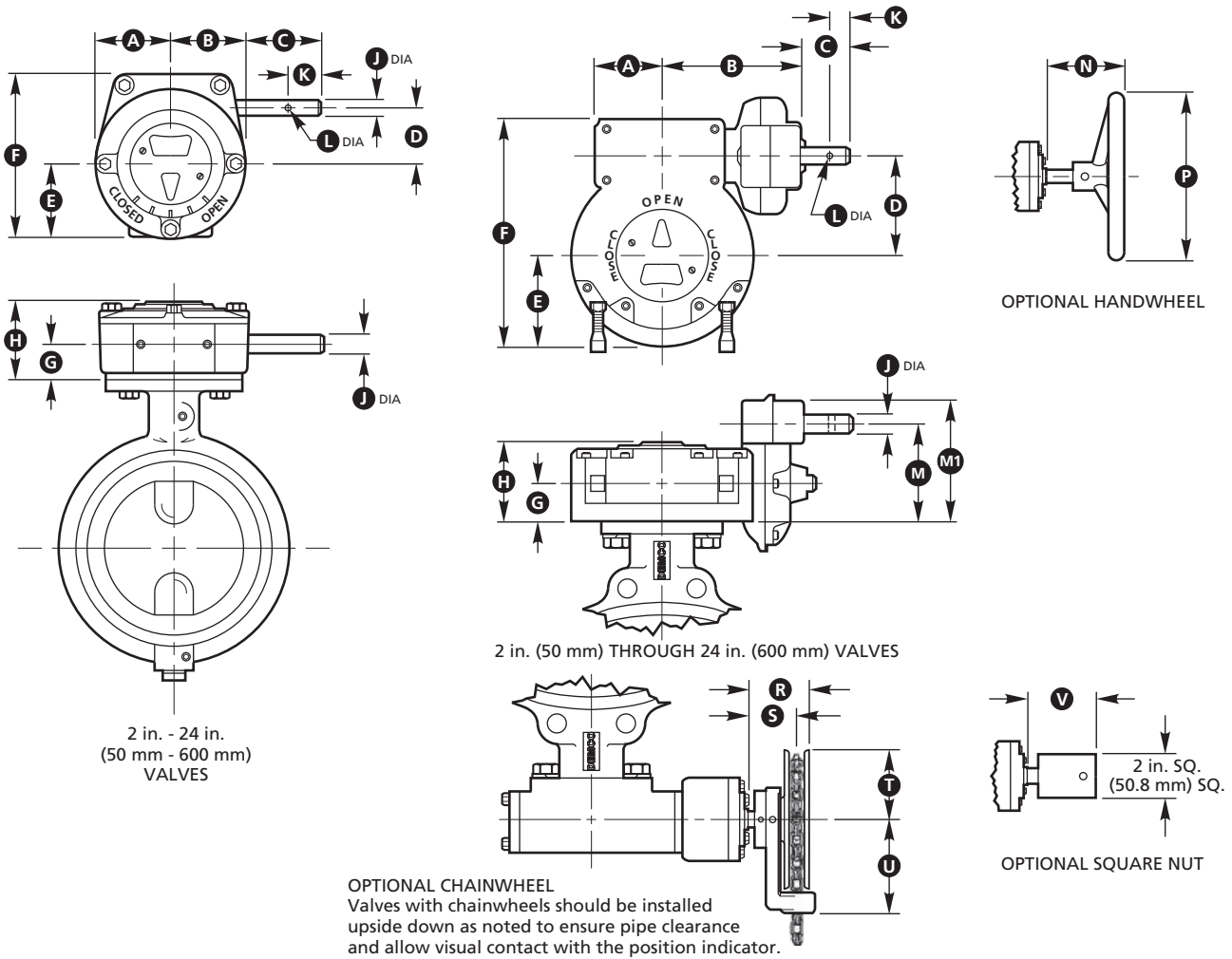

DIMENSIONAL DATA

Size in.	A	B	C	D	E	F	G	H	J	K	L	M	M1	N	P	R	S	T	U	V
2 to 6	1.80	1.80	3.80	1.64	1.59	4.97	0.90	2.30	0.623	1.00	0.19	-	-	4.80	6	4.80	4.10	3.50	4.80	4.60
8 to 10	2.88	2.88	3.38	2.50	2.88	6.50	1.38	3.00	0.623	1.00	0.19	-	-	4.32	6	4.32	3.72	3.50	4.80	4.12
12	2.88	2.88	3.38	2.50	2.88	6.50	1.38	3.00	0.623	1.00	0.19	-	-	5.02	8	4.32	3.72	3.50	4.80	4.12
14	2.88	2.88	5.12	2.50	2.88	6.50	1.38	3.00	0.623	1.25	0.19	-	-	6.56	12	5.88	5.25	5.81	5.75	5.69
16	2.88	2.88	5.88	2.50	2.88	6.50	1.38	3.00	0.623	1.25	0.25	-	-	11.00	18	7.69	6.38	9.12	8.69	6.75
18 to 20	3.12	3.12	7.12	3.00	3.12	7.69	1.50	3.25	1.000	1.25	0.25	-	-	11.25	18	8.94	7.63	9.12	8.69	8.00
24	3.44	3.44	5.28	3.63	3.25	8.38	1.63	3.56	1.000	1.25	0.38	-	-	10.91	24	7.59	5.91	11.00	12.25	6.16
30	4.56	8.88	4.52	4.63	4.63	11.08	2.00	4.44	1.000	1.25	0.39	6.00	7.38	8.65	18	7.59	6.28	9.12	8.69	5.41
36	5.88	9.12	4.56	6.25	5.88	14.50	2.31	5.00	1.000	1.25	0.39	6.36	8.00	10.19	24	8.13	6.44	11.00	12.25	5.44
Size mm																				
50 to 150	46	46	97	42	40	126	23	58	15.8	25	4.8	-	-	122	152	122	104	89	122	117
200 to 250	73	73	86	64	73	165	35	76	16	25	4.8	-	-	110	152	110	94	89	122	105
300	73	73	86	64	73	165	35	76	16	25	4.8	-	-	128	203	110	94	89	122	105
350	73	73	130	64	73	165	35	76	16	32	4.8	-	-	167	305	149	133	148	146	145
400	73	73	149	64	73	165	35	76	16	32	6.4	-	-	279	457	195	162	232	221	171
450 to 500	79	79	181	76	79	195	38	83	25	32	6.4	-	-	286	457	227	194	232	221	203
600	87	87	134	92	83	213	41	90	25	32	9.7	-	-	277	610	193	150	279	311	156
750	116	226	115	118	118	281	51	113	25	32	9.9	152	187	220	457	193	160	232	221	137
900	149	232	116	159	149	368	59	127	25	32	9.9	162	203	259	610	207	164	279	311	138

* DT-1 Gear operator dimensions became standard gear operator midyear 2000 (for old style DT-3, consult factory).

BUTTERFLY VALVES STEM EXTENSIONS

Fabricated from carbon steel or stainless steel, stem extensions are contained in a tubular housing.

Lengths from 3 inches to 16 feet are fabricated to order.

Torsional deflection of lengths over 16 feet requires special design consideration and is available by special order only.

STEM EXTENSIONS

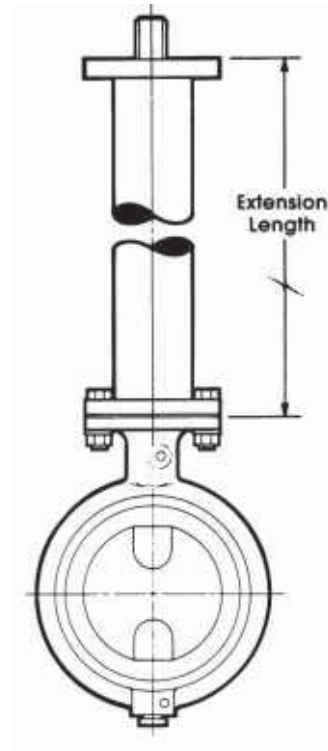

HOW TO ORDER 2 in. through 12 in. (50 mm through 300 mm)

XXXXX	-	XXX
Base Part Number		Length in. (mm)

HOW TO ORDER 14 in. through 24 in. (350 mm through 600 mm)

XXXXX	-	XXXX0
Base Part Number		Length in. (mm)

Description	in. (mm)	2 to 4 (50 to 500)	5 to 6 (125 to 150)	8 (200)	10 (250)	12 (300)	14 (350)	16 (400)	18 to 20 (450 to 500)	24 (600)
Carbon Steel		23318	23319	23320	23321	23322	24529	24530	24531	24532

* Note: Consult factory for 30 in., 36 in., (750 mm, 900 mm) valve stem extensions.

BUTTERFLY VALVES GENERAL TECHNICAL INFORMATION

Pressure Rating

Three drop tight pressure ratings are offered for DEMCO Butterfly Valves. Normally, 200 psi shut-off is used in butterfly applications. However, 285 psi shut-off is optionally available for higher pressure applications. For smaller actuator sizing, 50 psi valves offer reduced torque.

For **minimum torque**, throttling valves, which do not provide drop tight closure, are available.

Vacuum Rating

DEMCO Butterfly Valves will seal against **10 microns of vacuum** (29.9 inches of mercury). For reduced torque and extended seat life, 50 psi discs are recommended for the dry service conditions found in many vacuum applications.

End-of-Line Service

Lug body valves may be used in end-of-line service, with downstream piping removed. (**Weld neck or socket flanges, only, can be used for this service.**) Since upstream pressure is excluded between the flange and the seat face by the exclusive DEMCO flange seal, there is no effective force to slide the seat downstream. DEMCO Lug Butterfly Valves are recommended for **liquid** service up to 200 psi with downstream piping removed.

Lug body valves are recommended for isolation of pumps, control devices or other system components which may need to be removed for repair or replacement.

Lug valves are also suitable for installation at points from which piping expansions may proceed. Such valves are normally blanked with blind flanges, to protect the exposed seats, until new piping is attached.

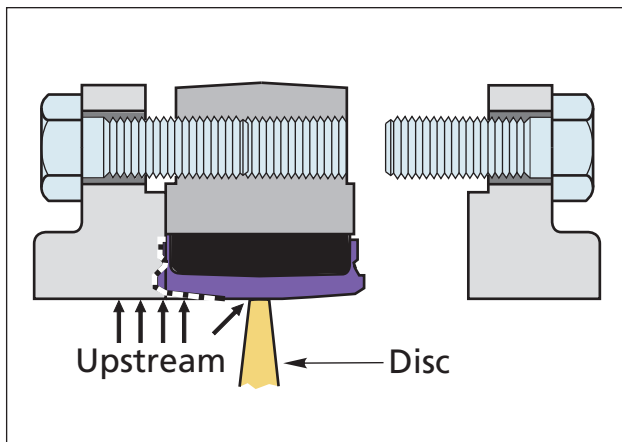

LUG VALVE CONNECTION WITH
DOWNSTREAM FLANGE REMOVED

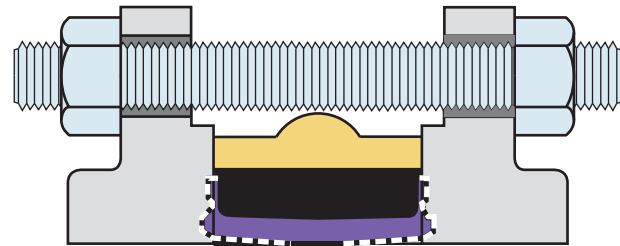

WAFER VALVE CONNECTION

Marking

Each valve is positively identified by marking and tagging per MSS SP 25.

Actuation

Positive latch handles, worm gear operators and automatic actuators are available and totally interchangeable on the DEMCO valve.

The DEMCO top flange is dimensionally compatible with other competitive butterfly valves. With optional "utility top" stem, the DEMCO valve interchanges directly with competitive valves, allowing valve replacement without the need for new actuation.

Installation and Maintenance

DEMCO Butterfly Valves are bi-directional, with identical flow-way from either face. To install, simply close the valve, insert between flanges and make up with studs or cap screws. No regular maintenance or lubrication is ever required. Disassembly is simple, for inspection or replacement of parts.

Open the valve, remove handle or actuator, remove tangential pins, pull out the stems and push the disc and seat out of the body. Reassemble in reverse order, with a small amount of general purpose non-hydrocarbon based lubricant on the outside of stems, seat and disc flats.

Steel or cast iron flanges of either raised or flat-faced type are suitable for use with DEMCO Butterfly Valves. Plastic flanges are subject to damage at installation by over-tightening the bolting and may deflect or "cup," resulting in flange leaks. Refer proposed plastic flange installations to DEMCO Valve Quotations Department for review and recommendation.

Throttling discs, with no seat interference, do not provide a stem seal. Stem O-rings are provided for this application. Flange gaskets assist the O-rings in 2 in. through 12 in. (50 mm through 300 mm) valves, and must be used with throttling discs, only.

BUTTERFLY VALVES GENERAL TECHNICAL INFORMATION

This nomograph gives corresponding values for the parameters of flow rate, valve size, disc angle and pressure drop of DEMCO Butterfly Valves in 1.0 specific gravity water service at 68°F (20°C).

The lower right-hand corner of the graph with heavy line border represents line velocities below 15 feet per second and is normally used for valve sizing in liquid applications.

Butterfly Valves are economical throttling devices. Reliable throttling can be attained at disc openings from 25° to 70°.

Sample Computation for Water
Water, with specific gravity of 1.0 and flow rate of 1200 gpm, through 6 in. (160 mm) Butterfly Valve.

Required: Pressure drop at full and 75° disc opening.

Project horizontally from 1200 gpm to 6 in. (150 mm) valve curve, then vertically upward to full open valve curve, then horizontally to read 0.35 psi pressure drop. Continue upward projection to intersect 75° opening curve, then horizontally to read 0.8 psi pressure drop.

Sample Computation for Air
Air, with density of 0.217 lbs./cu. ft., flow rate of 40,000 cu. ft./hr., through 5 in. (125 mm) Butterfly Valve.

Required: Pressure drop through full open valve.

Disregarding change in gas condition by pressure drop across valve, proceed from 40,000 cu. ft./hr., as in liquid computation, to read 15 psi pressure drop.

Convert pressure drop from water to air by multiplying this value times the ratio of air-to-water densities:

$$15 \text{ psi} \times \frac{0.217}{62.4} = 0.052 \text{ psi}$$

To determine pressure drop for any fluid, multiply value obtained from the nomograph by the quotient of the fluid density, in pounds per cubic foot, divided by 62.4.

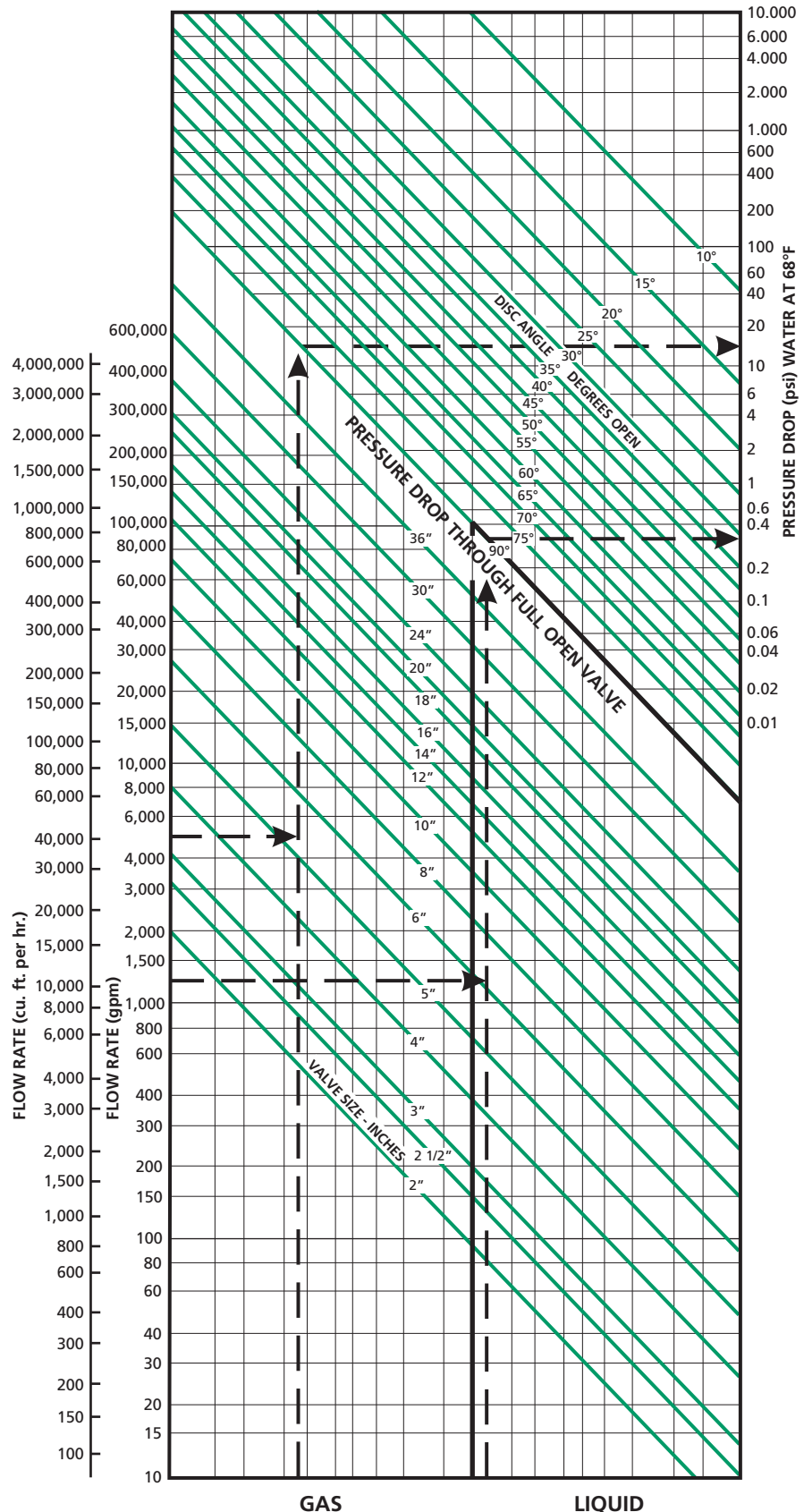

BUTTERFLY VALVES GENERAL TECHNICAL INFORMATION

General Dimensions 2 in. through 20 in. (50 mm through 500 mm)

Dimensions		Valve Size in. (mm)	2 (50)	2 1/2 (65)	3 (80)	4 (100)	5 (125)	6 (150)	8 (200)	10 (250)	12 (300)	14 (350)	16 (400)	18 (450)	20 (500)
A-Schedule 40 Flange ID*	(Except Slip On)		2.07 (53)	2.47 (63)	3.07 (78)	4.03 (102)	5.05 (128)	6.07 (154)	7.98 (203)	10.02 (255)	12.00 (305)	13.25 (337)	15.25 (387)	17.25 (438)	19.25 (489)
	(Slip On)		2.44 (62)	2.94 (75)	3.57 (91)	4.57 (116)	5.66 (144)	6.72 (171)	8.72 (221)	10.88 (276)	12.88 (327)	14.14 (359)	16.16 (410)	18.18 (462)	20.20 (513)
B-Seal Diameter			2.65 (67)	3.15 (80)	3.78 (96)	4.78 (121)	5.84 (148)	7.03 (179)	8.96 (228)	11.09 (282)	13.09 (332)	14.14 (359)	16.16 (410)	18.18 (462)	20.20 (513)
C-Raised Face Diameter			3.62 (92)	4.12 (105)	5.00 (127)	6.18 (157)	7.31 (186)	8.50 (216)	10.62 (270)	12.75 (324)	15.00 (381)	16.25 (413)	18.50 (470)	21.00 (533)	23.00 (584)
D-Valve Body Diameter			4.12 (105)	4.87 (124)	5.37 (136)	6.87 (174)	7.75 (197)	8.75 (222)	11.00 (279)	13.37 (340)	16.12 (409)	17.20 (437)	19.27 (489)	21.43 (544)	23.60 (599)
E-Seat OD			3.12 (79)	3.62 (92)	4.25 (108)	5.25 (133)	6.31 (160)	7.46 (189)	9.43 (240)	11.56 (294)	13.56 (344)	15.14 (385)	17.04 (433)	19.06 (484)	21.08 (535)
F-End-to-End	Threaded ASME Socket & Slip On		3 3/4	4 1/8	4 1/4	4 3/4	5 1/8	5 3/8	6 1/16	6 5/8	7 5/8	7 1/2	9	9 13/16	10 11/16
	Weld End ASME		6 3/4	7 3/8	7 3/8	8 1/8	9 1/4	9 1/4	10 9/16	10 3/4	12 1/4	13	14	15 7/16	16 5/16
	Grooved		6 5/8	7 3/16	7 1/8	7 7/8	8 15/16	8 7/8	10 3/16	10 5/16	11 13/16	-	-	-	-
G-Seat ID			2 1/4	2 13/16	3 5/16	4 3/16	5 1/16	6 1/16	7 15/16	10	11 15/16	13 5/32	15 7/32	17 5/32	19 5/32
H-Disc Chord**, Resilient Seated Valves			1.467 (37)	2.144 (54)	2.743 (70)	3.601 (91)	4.582 (116)	5.624 (142.8)	7.428 (189)	9.382 (238)	11.35 (288)	12.86 (327)	14.72 (374)	16.61 (422)	18.53 (471)
J-Outside-to-Outside	ASME 150		3.25 (83)	3.62 (92)	3.75 (95)	4.00 (102)	4.12 (105)	4.25 (108)	4.81 (122)	5.12 (130)	5.75 (146)	5.75 (146)	6.87 (174)	7.56 (192)	8.31 (211)
	Resilient Seated-sq. in.		2.33	3.92	5.93	10.01	14.98	22.09	39.43	61.52	89.54	111.2	150.5	186.1	238.1
Throughput Area	% Sch. 40 pipe		70%	82%	80%	79%	73%	76%	79%	78%	80%	82%	85%	83%	87%
	Number of Studs		4	4	4	8	8	8	8	12	12	12	16	16	20
Number of Capscrews			8	8	8	16	16	16	16	24	24	24	32	32	40
Size of Studs or Capscrews-Threads per in.			5/8 -11	5/8 -11	5/8 -11	5/8 -11	3/4 -10	3/4 -10	3/4 -10	7/8 -9	7/8 -9	1 -8	1 -8	1 1/8 -7	1 1/8 -7
Length of Studs			5	5 1/2	5 1/2	5 3/4	6 1/2	6 1/2	7	7 1/2	8 1/4	8 1/4	10	10 1/2	11 3/4
Length of Capscrews (in.)			1 1/2	1 1/2	1 1/2	1 3/4	1 3/4	2	2 1/4	2 1/4	2 1/2	2 1/2	3 1/4	3 1/2	4

* DEMCO Butterfly Valves are designed to seal without flange gaskets against flange faces with inside diameters between slip-on flange bore and Schedule 40 weld neck flange bore.

** 2 in. through 12 in. (50 mm through 300 mm) disc will open into Schedule 80 pipe ID.

General Dimensions

24 in. through 36 in. (600 mm through 900 mm)

Dimensions	Valve Size in. (mm)	24 (600)	30* (750)	36* (900)
A-Standard Flange ID (Except Slip On)		23.25 (591)	29.25 (743)	35.25 (895)
B-Seal Diameter		24.25 (616)	30.00 (762)	35.94 (913)
C-Raised Face Diameter		27.25 (692)	-	-
D-Valve Body Diameter		28.23 (717)	34.05 (865)	40.49 (1028)
E-Seat OD		25.49 (647)	31.47 (799)	37.63 (956)
F-End-to-End Weld End, ASME		18.00 (457)	16.75 (425)	18.63 (473)
G-Seat ID		23 1/4	29 5/16	35 5/16
H-Disc Chord		22.57 (573)	28.67 (728)	34.70 (881)
J-Outside-to-Outside, ASME		9.75 (248)	10.75 (273)	12.63 (321)
Number of Studs		20	*	**
Number of Capscrews		40	56	64
Size of Capscrews-Threads per in.		1 1/4 -7	1 1/4 -7	1 1/2 -6
Length of Studs		12 1/2	*	**
Length of Capscrews		4	5	***
Throughput Area	sq. in.	352.4	546	800
	% std. pipe	88%	81%	82%

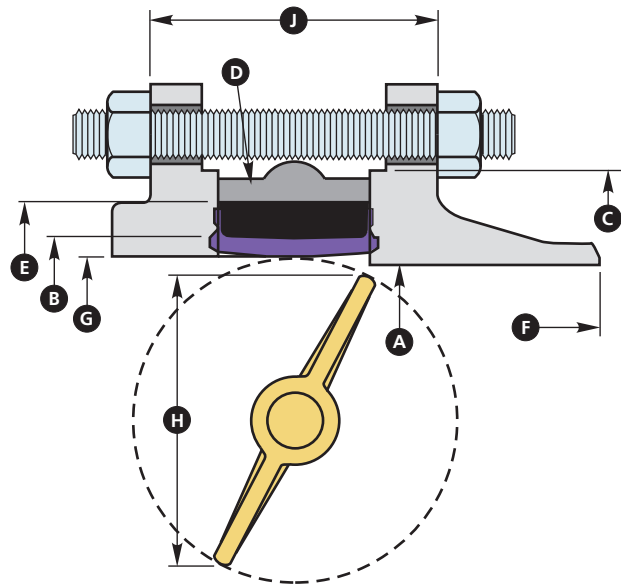

* 24 Studs 1 1/4-7 x 15 1/2; 8 capscrews 1 1/4-7 x 5.

** 28 Studs 1 1/2-6 x 18 1/2; 8 capscrews 1 1/2-6 x 5 1/2.

*** 56 Screws 1 1/2-6 x 6; 8 screws 1 1/2-6 x 5 1/2

• Dimensions are for ASME Class 150 Series A flanges or MSS SP-44 flanges. Consult factory for ASME Class 125 flanges.

BUTTERFLY VALVES GENERAL TECHNICAL INFORMATION

Flow Coefficients (C_v)

Degree Open	Valve Size in. (mm)															
	2 (50)	2 1/2 (65)	3 (80)	4 (100)	5 (125)	6 (150)	8 (200)	10 (250)	12 (300)	14 (350)	16 (400)	18 (450)	20 (500)	24 (600)	30 (750)	36 (900)
90°	145	225	325	590	1,125	1,950	3,250	5,000	7,500	10,000	13,600	18,000	22,600	30,000	47,000	70,000
80°	115	175	260	510	1,000	1,650	2,725	4,300	6,050	8,100	11,500	14,300	18,000	25,000	38,000	60,000
75°	95	135	215	410	830	1,350	2,200	3,600	5,000	6,700	9,500	12,100	15,000	21,000	31,500	48,000
70°	70	105	160	305	625	1,030	1,750	2,750	4,050	5,100	7,100	9,200	11,500	16,500	25,500	39,500
60°	53	83	125	235	490	800	1,300	2,150	3,100	4,100	5,100	7,100	8,700	11,750	18,000	28,000
50°	27	42	63	120	250	410	700	1,150	1,600	2,200	2,650	3,700	4,600	6,100	9,700	15,000
40°	17	26	38	73	155	250	420	670	1,000	1,300	1,700	2,300	2,800	3,800	6,000	9,200
30°	9	15	22	42	88	145	250	390	550	750	900	1,250	1,600	2,200	3,500	5,300
25°	6	10	15	28	60	98	170	260	380	500	650	900	1,125	1,500	2,300	3,500

C_v values, given above, may be employed in the formula:

$$Q = C_v \times \sqrt{\frac{\Delta P \times 62.4}{D}}$$

Where:

- Q = Gallons per minute of flow through the valve.
- ΔP = Pounds per square inch pressure drop across the valve.
- D = Density of fluids in pounds per cubic foot.

Pressure drop is computed by rearranging the formula to:

$$\Delta P = \frac{Q^2 \times D}{C_v^2 \times 62.4}$$

Sample Computations

What is the **flow rate** of water at ambient temperature through a 4 in. (100 mm) butterfly valve 70° open when pressure drop across the valve is 0.5 psi? (Density of water at 68°F is 62.4 pounds per cubic foot.)

$$Q = C_v \times \sqrt{\frac{\Delta P \times 62.4}{D}}$$

$$= 305 \times \sqrt{\frac{0.5 \times 62.4}{D}}$$

$$= 305 \times 0.707$$

$$Q = 215.6 \text{ gallons per minute}$$

What is the **pressure drop** across an 8 in. (200 mm) butterfly valve fully open, flowing 2000 gallons per minute of solvent with a density of 55 pounds per cubic foot?

$$\Delta P = \frac{Q^2 \times D}{C_v^2 \times 62.4}$$

$$= \frac{(2000)^2 \times 55}{(3250)^2 \times 62.4}$$

$$\Delta P = 0.33 \text{ pounds per square inch}$$

Water Hammer

Water hammer is a series of shocks in a piping system caused by rapidly stopping the flow of fluid in that system. Although it is difficult to measure pressure spikes caused by water hammer shock with ordinary equipment, maximum obtainable pressures caused by instantaneous valve closure can be approximated by the following formula:

$$\text{Pressure (max)} = \text{Interrupted velocity (fps)} \times 58 \text{ psi/fps}$$

In other words, pressure increases 58 psi for each foot per second of interrupted pipe line velocity.

A pipe carrying fluid at 15 feet per second velocity will have an instantaneous pressure increase of 870 psi under rapid closure conditions.

The effects of water hammer are seen in a butterfly valve as bent disc and stems, broken bodies or both. Water hammer can be minimized or eliminated by slowing valve closure time in accordance with the following formula:

$$\text{Time seconds} = \frac{0.14Q}{S(P)}$$

Where:

- Q = Flow in gpm.
- S = Upstream pipe size in sq. ft.
- P = Pressure rating of the valve in psi.

Generally, a closing time of 6 to 8 seconds is sufficient to eliminate water hammer.

BUTTERFLY VALVES GENERAL TECHNICAL INFORMATION

Cavitation Data

Liquid flow is accelerated as it passes through a valve in such a manner that pressure is decreased below the vapor pressure and bubbles form. Immediately downstream of the valve, velocity decreases while pressure increases and the bubbles collapse causing noise and possible mechanical damage to the valve and piping. This is called cavitation.

Cavitation can often be identified by the noise of the collapsing bubbles which sounds like gravel flowing in the pipe.

Generally butterfly valves operate with high flow capacities and at low pressure differentials and are not particularly susceptible to cavitation.

When butterfly valves are used as control valves, one can assure that cavitation will not occur by applying the following simplified formula:

$$\Delta P_{max} = K_c(P_1 - P_v)$$

Where:

- ΔP_{max} = Differential pressure across the valve.
- K_c = Cavitation constant (approximately .35 for butterfly valves).
- P_1 = Inlet pressure (psia).
- P_v = Vapor pressure of the flowing liquid (psia).

Example:

What is the maximum pressure drop possible through a butterfly valve at 100 psig inlet pressure with water at 68°F (.339 psia vapor pressure)?

$$\Delta P_{max} = K_c(P_1 - P_v)$$

Under the above conditions it is possible to take a 40.03 psi pressure drop across the valve before cavitation will begin.

Torque

The torque (turning effort) required to operate a given butterfly valve is determined by two factors: friction of disc and seat due to interference and dynamic forces of flow through the valve which tend to open or close the valve. Actuator torque output must meet or exceed the maximum torque requirement of the valve.

Normal Wet Opening Torque requirements due to interference are tabulated below. Dry service will increase opening torque significantly. Consult factory for dry service torque requirements.

The disc of a butterfly valve, in partially opened condition, is subject to "lift" forces from passage of fluid over its surfaces. This effect is analogous to an airplane wing and results in an unbalanced turning force on the disc. Dynamic torque is proportional to pressure drop through the valve and may become significant in some applications.

Dynamic torque typically is a maximum at about 70° disc opening. Under high differential pressure conditions, such torque may exceed the design strength of stems, connections or actuators. The curves at right may be used to calculate dynamic torque for DEMCO Butterfly Valves and should be consulted in any case where high differential pressure may occur during operation of a valve.

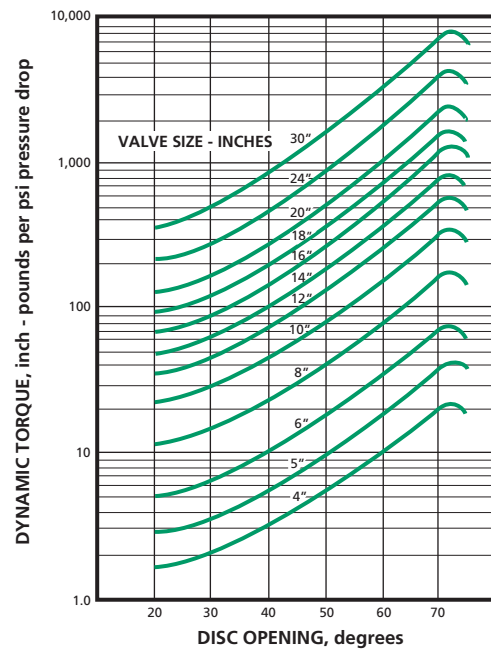

TORQUES

Butterfly Valve Torques (except Series NE I-T)**- Normal Wet Opening

Valve Size	in. (mm)	2 (50)	2 1/2 (65)	3 (80)	4 (100)	5 (125)	6 (150)	8 (200)	10 (250)	12 (300)	14 (350)	16 (400)	18 (450)	20 (500)	24 (600)	30 (750)	36 (900)
285 psi Shut-Off		225	326	510	765	1190	1530	2550	4125	7000	-	-	-	-	-	-	-
200 psi Shut-Off		132	192	300	450	700	900	1500	2650	4500	-	-	-	-	-	-	-
150 psi Shut-Off		-	-	-	-	-	-	-	-	-	7740	10280	12600	15600	30000	50000	67500
50 psi Shut-Off		108	108	192	264	450	550	1000	1800	3000	4500	6500	8400	10800	20000	30000	50000
Throttling*		72	72	90	108	144	180	350	700	1160	1660	2800	3400	5000	8400	-	-

Butterfly Valve Torques (except Series NE I-T)**- Three-Way Assemblies

Valve Size	in. (mm)	2 (50)	2 1/2 (65)	3 (80)	4 (100)	5 (125)	6 (150)	8 (200)	10 (250)	12 (300)	14 (350)	16 (400)	18 (450)	20 (500)	24 (600)	30 (750)	36 (900)
285 psi Shut-Off		338	489	765	1148	1785	2295	3825	6188	10500	-	-	-	-	-	-	-
200 psi Shut-Off		198	288	450	675	1050	1350	2250	3975	6750	-	-	-	-	-	-	-
150 psi Shut-Off		-	-	-	-	-	-	-	-	-	11610	15420	18900	23400	45000	-	-
50 psi Shut-Off		162	162	288	396	675	825	1500	2700	4500	6750	9750	12600	16200	30000	-	-
Throttling*		144	144	180	216	288	360	700	1400	2320	3320	5600	6800	10000	16800	-	-

* When line velocity exceeds 15 feet per second, dynamic torque exceeds opening torque.

** For Series NEI-T Butterfly Valve torque requirement, consult factory.

BUTTERFLY VALVES STANDARD MATERIAL DATA

Bodies

Description	NE-C	NF-C 14 - 24	NF-C 30 & 36	NE-I	NE-D	NE-I Sanitary	NE-T
See page 6 for Assembly Part Number							
Ductile Iron	A395 (60-40-18) *	Lug	Lug	Wafer/Lug	Wafer	Wafer	Wafer/Lug
	ENC Coated				Wafer		Wafer/Lug
Gray Iron	A48 (Class 20)	Wafer					Wafer
	A126 (Class B)		Wafer				
Bronze	B148 (952)		C/F	Wafer/Lug		Wafer/Lug	Wafer/Lug
Steel	A216 (WCB) *		Lug	Wafer/Lug			Wafer/Lug
Stainless Steel	A351 (CF8M)			Wafer/Lug		Wafer/Lug	Wafer/Lug
Aluminum	B26			Wafer		Wafer	Wafer

Discs

Ductile Iron/ Nickel Plated	A536 (65-45-12)	•	•	•	•	•	
Ductile Iron/ PVF Coated	A536 (65-45-12)	•	•		•	•	
Aluminum Bronze	B148 (954)	•			•	•	
	B148 (955)		•	•			
316 SS	A743 (CF8M)	•	•	•	•	•	•
Monel **	A494 (M30C)	•	•		•	•	
Alloy 20, 29 Ni-20 Cr	A743 (CN-7M)	•			•	•	•
Hastelloy C ** 61 Ni-17 Mo-17 Cr	A494 (CW-2M)	•			•	•	•

Stems

416 SS	QQ-S-764-B	•	•	•	•	•	•
316 SS	AMS 5648 B	•	•	•	•	•	•
17-4 PH SS	AMS 5643	•	•		•	•	•
Monel **	B164 (Class A)	•	•	•	•	•	

* Conforms to USCG Marine requirements as outlined in 46 C.F.R., part 56.

**See material trademark on page 32. Consult factory for special material requirements.

Seats See pages 5, 6 and 7 for seat material description and part number scheme for available options for different valve series.

Buna-N is a general purpose elastomer compounded for maximum hydrocarbon or petroleum resistance.
0°F to +180°F *Same as Nitrile, Hycar*, NBR*

General Service EPDM is recommended for water service. Resistance to saturated steam to 275°F is excellent. EPDM is suitable in alkaline solutions. EPDM is not suitable for oil or hydrocarbons. Peroxide cured +20°F to +275°F

Food Grade EPDM is formulated in compliance with FDA guidelines published in the Code of Federal Regulations, Title 21, paragraph 177.2600. This material is suitable for food service, except milk and edible oils. Peroxide cured +20°F to +275°F Sulfur cured -30°F to +225°F *Same as EPDM, Nordel**

Black Neoprene complies with FDA guidelines and is principally recommended for food and beverage service. It is resistant to vegetable oils, brine and oxygen.
0°F to +180°F *Same as Polychloroprene, CPE*

White Neoprene complies with FDA guidelines and offers chemical resistance comparable to black neoprene but uses fillers other than carbon black to provide white coloration. Physical properties are not as good as black neoprene, and white neoprene should be used only when black cannot be tolerated. Storage should be under low light conditions to prevent discoloration. 0°F to +180°F

Hypalon* is compounded for chemical resistance and is excellent in acids and hydrocarbons.
0°F to +180°F *Same as CP*

FKM is excellent at elevated temperatures and also in harsh chemical environments. FKM is not suitable for hot water or steam. +20°F to +300°F *Same as Fluoroelastomer*

Natural Rubber is generally superior to other elastomers in abrasion resistance and is recommended for dry material handling. Use in oils and solvents is not recommended.
-30°F to +150°F

Fluorosteam seats offer heat and chemical resistance to hydrocarbons and hot water or saturated steam. Maximum temperature capability is dependent on fluid resistance, pressure and flow rates. +20°F to +275°F

ETM-30230 is compounded to combine many of the better media properties of Buna-N, EPDM or Neoprene for service in hydrocarbons, gasoline, solvents, animal oils and vegetable oils with a wide temperature range (-30°F to 230°F). Abrasion resistance is equal to Buna-N. Resistance to hydrogen sulfide and carbon dioxide are superior to Buna-N. -30°F to +230°F

NEI-T Teflon* SEAT is Buna-N, or EPDM elastomer bonded to a virgin TFE covering providing an inert, aseptic non-stick surface which is excellent for sanitary food service applications. 0°F to +250°F

Other Seat Elastomers are available for special applications. Consult factory.

* See material trademark note on page 32.

BUTTERFLY VALVES MATERIAL SELECTION GUIDE

The following application data is for use in determining the available material most likely to give satisfactory service and is not meant to imply any type warranty. However, certain factors such as temperature, concentration and combinations of chemicals may affect the fluid resistance of any material. In questionable applications, testing is always the most positive way to determine suitability. Some materials are available in certain valve sizes and series only.

APPLICATION CODE	STEM & DISC								SEAT							
	Nickel Plated Ductile Iron	416 SS	316 SS	Monel*	Aluminum Bronze	Alloy 20	Hastelloy C*	PVF	Buna-N	Neoprene	Hypalon*	FKM	EPDM	Natural Rubber	ETM-30230	
Acetaldehyde	U	U	E	E	U	E	E	G	G	F	U	F	E	U	-	
Acetic Acid-Crude	U	U	E	E	F	U	E	E	G	E	E	-	-	-	-	
Acetic Acid-Pure	U	U	E	F	F	E	E	E	G	E	E	-	-	-	-	
Acetic Acid-10%	U	U	E	F	U	E	E	-	G	E	E	-	-	-	G	
Acetic Acid-80%	U	U	E	F	U	E	E	-	G	E	E	-	-	-	-	
Acetic Acid-Anhydrite	U	U	E	F	U	E	E	U	U	E	E	U	F	F	U	
Acetone	G	G	E	E	E	E	E	U	U	U	U	E	F	U	U	
Acetophenone	U	U	G	E	U	-	-	F	U	-	-	E	-	-	U	
Acetylene	G	E	E	E	E	E	U	-	G	F	F	E	-	F	G	
Acrylonitrile	G	G	E	E	E	-	-	U	U	F	F	U	U	U	-	
Air (dry)	E	E	E	E	E	-	-	-	E	E	E	E	G	-	-	
Alcohol-Amyl	F	G	E	E	E	E	-	E	F	F	G	G	E	G	E	
Alcohol-Butyl	F	G	E	E	E	E	E	E	F	G	G	E	F	F	-	
Alcohol-Ethyl	U	-	E	E	E	E	E	E	G	G	G	G	G	G	E	
Alcohol-Methyl	U	-	E	E	E	E	E	-	F	E	E	F	E	G	-	
Alum-Ammonium	U	-	G	-	-	-	-	-	G	G	F	G	-	F	-	
Alum-Chrome	U	-	G	-	-	-	-	-	G	G	G	G	-	F	-	
Alum-Potassium	U	G	-	-	G	-	-	-	G	G	F	E	G	-	-	
Alumina	G	G	G	G	G	E	E	-	E	F	G	G	E	E	-	
Aluminum Chloride	U	U	F	G	U	E	-	E	G	G	G	E	E	G	G	
Aluminum Fluoride	U	-	G	G	-	E	-	E	G	G	G	G	E	G	G	
Aluminum Hydroxide	U	-	G	G	G	-	-	E	G	G	-	G	G	-	-	
Aluminum Sulphate	U	G	G	-	U	G	E	-	E	E	E	E	E	E	-	
Amines	U	F	E	G	-	E	U	-	U	U	U	U	F	-	-	
Ammonia, Anhydrous	F	-	E	E	U	-	E	E	G	G	U	U	G	U	U	
Ammonia Solutions	F	G	E	G	U	E	E	-	G	G	U	U	G	U	U	
Ammonium Chloride 50% 180°F	U	F	G	G	U	E	E	E	E	E	E	E	E	E	G	
Ammonium Hydroxide	F	G	E	F	U	E	E	E	U	E	E	E	G	E	F	
Ammonium Nitrate 5% 60°F	F	G	E	U	U	E	E	E	E	E	G	E	E	G	G	
Ammonium Phosphate	U	G	E	G	U	E	E	E	E	E	E	E	E	G	G	
Ammonium Sulphate 90% 180°F	U	F	G	G	U	G	G	E	E	E	E	E	E	G	-	
Amyl Acetate	F	G	E	G	G	E	U	F	U	U	U	U	G	U	U	
Amyl Chloride	F	G	E	G	E	E	E	E	U	U	U	-	U	U	-	
Aniline 90% 70°F	F	G	G	G	U	E	E	F	U	U	U	F	F	U	U	
Aniline Dyes	F	G	E	E	F	E	E	-	U	F	F	G	-	-	U	
Antimony Chloride	U	-	-	G	-	-	E	-	G	G	G	E	-	-	U	
Arsenic Acid	U	G	G	G	U	E	-	E	E	E	E	E	G	G	G	
ASTM Oil #1	F	E	E	E	E	E	E	-	E	G	G	E	U	U	-	
ASTM Oil #3	F	E	E	E	E	E	E	-	E	U	U	E	U	U	-	
ASTM Ref. Fuel A	F	E	E	E	G	E	E	-	E	G	G	E	U	U	E	
ASTM Ref. Fuel B	F	E	E	E	G	E	E	-	G	F	F	E	U	U	E	
ASTM Ref. Fuel C	F	E	E	E	G	E	E	-	G	F	F	E	U	U	-	
Asphalt	E	E	E	E	E	E	E	-	G	-	-	E	U	U	E	
Barium Carbonate 60°F	U	-	G	G	G	-	E	E	E	E	-	-	E	-	-	
Barium Chloride	U	-	G	G	F	-	E	E	E	E	E	E	E	E	E	
Barium Hydroxide	F	E	E	G	U	E	-	E	E	E	E	E	E	G	E	
Barium Sulphate 60°F	U	-	E	G	G	-	-	E	E	E	-	-	E	-	E	
Barium Sulphide	F	E	G	F	U	E	-	E	E	E	U	-	-	U	-	
Beer (Beverage)	U	E	E	E	U	E	E	E	G	G	E	E	E	G	G	
Beet Sugar Liquors	F	E	E	E	F	E	-	-	E	E	G	E	-	G	-	
Benzaldehyde	F	E	E	G	E	E	-	E	U	U	U	U	E	U	U	
Benzene (Benzol) 70°F	F	E	E	G	E	E	E	G	U	U	U	G	U	U	U	
Benzoic Acid 5% 70°F	U	G	E	G	G	E	E	E	U	U	U	E	U	U	-	
Black Sulphate Liquor	F	G	E	-	F	E	-	-	G	G	G	E	G	F	-	
Bleaching Powder-Wet	U	G	G	-	U	E	-	-	G	E	F	-	-	F	-	
Borax (Sodium Borate)	U	F	E	E	U	E	E	E	G	E	E	E	E	G	G	
Boric Acid 5% 200°F	U	F	E	G	F	E	E	E	E	E	E	E	E	G	G	
Brine (Acid)	U	-	G	G	G	-	-	E	E	G	G	-	E	U	-	
Brine-Chlorinated	-	-	U	G	G	-	-	-	-	-	-	G	G	-	-	
Bromine-Gas	U	U	U	F	-	U	E	E	U	U	U	E	U	U	-	
Bromine-Water	U	U	U	F	-	U	E	E	U	G	G	E	U	U	-	
Butadiene	F	G	E	E	G	-	E	E	F	-	G	G	-	U	U	
Butane-Butylene	G	E	E	E	E	E	E	E	G	G	G	E	U	U	G	
Butyl Acetate	G	E	E	E	E	E	E	U	U	U	U	U	U	U	U	
Butyric Acid 5% 70°F	U	G	E	G	G	E	-	-	U	U	U	G	G	U	-	
Calcium Bisulfite	U	G	E	U	U	G	-	E	E	E	E	E	U	U	-	
Calcium Carbonate 60°F	F	-	G	E	G	-	E	E	E	E	-	E	-	-	-	
Calcium Chlorate 20% 160°F	-	G	E	G	U	E	E	E	-	E	E	-	-	-	-	

BUTTERFLY VALVES MATERIAL SELECTION GUIDE (Continued)

APPLICATION E - Excellent
CODE G - Good
 F - Fair
 U - Unsatisfactory

Stem & Disc
 Nickel Plated Ductile Iron
 416 SS
 316 SS
 Monel+
 Aluminum Bronze
 Alloy 20
 Hastelloy C+
 PVF
Seat
 Buna-N
 Neoprene
 Hypalon+
 FKM
 EPDM
 Natural Rubber
 ETM-30230

	Nickel Plated Ductile Iron	416 SS	316 SS	Monel+	Aluminum Bronze	Alloy 20	Hastelloy C+	PVF	Buna-N	Neoprene	Hypalon+	FKM	EPDM	Natural Rubber	ETM-30230
Calcium Chloride	F	G	G	G	E	G	E	E	E	E	E	-	-	-	E
Calcium Hydroxide 50% 175°F	F	E	E	E	U	E	E	E	G	E	E	-	-	-	G
Calcium Hypochloride	-	G	G	-	-	G	-	-	U	U	E	E	-	U	F
Calcium Sulphate 90% 60°F	F	E	E	G	E	E	-	E	F	F	-	E	-	-	-
Calgon	F	-	E	-	-	E	-	-	E	E	-	E	-	-	-
Caliche Liquor	U	-	E	-	-	E	-	-	E	E	E	E	E	E	-
Cane Sugar Liquors	F	E	E	G	E	E	-	-	E	E	-	-	-	-	G
Carbon Dioxide (Dry)	F	E	E	-	E	E	-	E	E	G	G	E	-	G	G
Carbon Disulfide	U	-	E	G	G	-	-	G	U	U	U	E	U	U	-
Carbon Tetrachloride (Dry)	U	G	G	E	G	E	-	E	U	-	-	E	-	-	F
Carbonic Acid	U	G	E	E	-	E	E	E	G	E	E	E	E	E	G
Caster Oil	G	G	E	E	G	E	E	E	G	E	E	E	G	G	G
Caustic Solutions 34% 200°F	U	G	E	F	U	E	E	-	F	F	F	E	G	U	F
China Wood Oil (Tung)	F	-	E	E	F	E	E	-	E	E	G	E	U	U	-
Chlorine Gas-Dry 70°F	U	F	G	G	G	G	E	E	U	U	G	E	F	U	-
Chlorobenzene 90% 70°F	F	E	G	G	G	E	-	E	U	U	U	G	U	U	U
Chloroform 70°F	F	G	E	E	G	E	-	E	U	U	U	E	U	U	-
Chlorosulfonic Acid 10%	U	U	G	F	G	U	E	F	U	U	U	U	U	U	-
Chocolate	-	-	-	-	-	-	-	-	E	U	-	-	-	-	-
Chromic Acid 5% 70°F	U	G	G	F	U	E	-	E	U	U	E	E	U	U	-
Citrus Acid 5% 150°F	U	F	E	G	F	E	E	E	E	E	E	E	E	F	E
Coconut Oil (Food)	U	U	E	G	G	E	-	E	E	F	F	E	F	U	-
Coffee (Food)	U	U	E	G	F	E	-	E	E	E	E	E	E	E	-
Copper Chromate	-	-	E	-	-	-	-	-	-	-	-	-	-	-	-
Copper Sulphate 80% 175°F	F	G	E	F	U	E	-	E	E	E	E	E	E	E	-
Corn Syrup	-	-	E	-	-	-	-	-	-	-	-	-	E	-	-
Cottonseed Oil	G	E	E	E	E	E	E	E	E	F	G	G	F	U	G
Creosol	U	F	E	E	-	E	-	F	U	U	U	F	U	U	-
Creosote	E	E	E	E	G	E	E	-	G	U	F	E	U	U	U
Cresylic Acid	U	G	E	G	G	E	-	G	U	U	U	E	U	U	-
Crude Oil	G	G	E	E	E	E	E	-	E	-	-	E	U	U	E
Cyclohexane	F	E	E	G	G	E	-	E	U	U	U	E	U	U	-
Dextrose (Food)	U	U	E	-	-	E	-	-	E	-	-	-	-	-	-
Diacetone	U	-	E	-	E	-	-	U	U	U	U	U	E	U	-
Diamylamine	F	E	E	-	E	E	-	-	G	F	-	U	-	G	-
Dichlorethene	U	-	G	G	G	G	-	F	U	U	-	G	U	-	U
Diesel Fuels	E	E	E	E	G	E	E	E	E	F	F	E	U	F	E
Diethyl Amine	F	E	E	G	E	E	-	U	G	F	F	U	F	U	-
Dimethane Sulfide	-	-	-	-	-	-	-	-	-	-	F	U	G	-	-
Dowtherms	G	E	E	E	G	E	-	-	U	G	G	E	-	-	U
Drilling Mud	G	-	E	E	G	-	-	-	E	F	E	E	-	G	E
Ethers	U	-	G	G	G	E	E	F	U	U	U	F	F	U	-
Ethyl Acetate	F	G	E	E	G	E	E	F	U	U	U	U	G	U	U
Ethyl Chloride 5% 60°F	F	G	E	G	E	E	E	E	E	G	G	G	G	G	G
Ethyl Glycol	G	E	E	E	E	E	E	E	E	G	E	E	E	E	-
Ethylene Dichloride	U	-	G	G	G	-	-	E	U	U	U	F	U	-	U
Ethylene Oxide	G	G	G	G	U	E	-	U	U	U	U	U	F	U	U
Ferric Chloride	U	U	U	U	U	-	U	E	E	G	G	E	E	E	G
Ferric Nitrate (pH7+) 5% 60°F	U	-	G	F	U	E	-	E	E	E	E	E	E	E	E
Ferric Sulphate 5% 60°F	U	-	E	E	U	-	-	E	E	E	E	E	E	E	E
Ferrous Sulphate	F	G	G	-	U	E	-	E	E	E	-	E	E	E	-
Fluorine 70°F	U	U	F	G	U	G	-	E	G	F	G	G	F	-	-
Fluorosilicic Acid	U	F	G	G	F	E	-	E	E	G	E	-	-	G	-
Formaldehyde 70°F	U	G	E	G	E	E	E	G	F	-	E	E	-	F	F
Formic Acid 5% 150°F	U	G	E	G	G	E	E	E	G	E	E	E	E	E	G
Freon 11	F	E	E	E	E	E	-	E	G	G	E	G	U	-	-
Freon 12	F	E	E	E	E	E	-	E	G	G	U	U	U	-	F
Freon 22	F	E	E	E	E	E	-	E	U	-	E	U	E	-	F
Freon 113	F	E	E	E	E	E	-	-	G	G	E	G	U	U	F
Freon 114	F	E	E	E	E	E	-	-	G	G	F	F	U	-	F
Fructose	-	-	E	-	-	-	-	-	-	-	-	-	E	-	-
Fruit Juices (Food) 70%	U	U	E	E	U	E	E	-	E	E	F	E	G	G	-
Fuel Oil	F	E	E	E	E	E	E	E	G	F	F	E	U	U	E
Furfural	F	E	E	G	G	E	E	U	U	U	U	U	F	U	U
Gallic Acid 5% 200°F	U	-	E	G	-	E	E	F	G	G	G	E	G	E	-
Gasohol	F	G	E	-	G	-	-	E	U	-	-	G	U	-	U
Gasoline-Regular	G	E	E	E	E	E	E	E	G	-	G	E	U	U	E
Gasoline-Unleaded	F	E	E	E	E	-	-	E	U	-	-	E	U	-	G
Gelatin (Food)	U	U	E	G	G	E	-	-	E	E	E	E	E	E	E
Glucose	U	F	E	-	E	E	-	E	E	E	E	E	E	E	E
Glycerine/Glycerol 70°F	F	E	E	G	G	E	E	E	E	E	E	E	E	E	E
Heptane	F	G	E	G	E	E	-	E	E	G	G	E	U	U	-
Hexane	F	G	E	G	E	E	-	E	E	G	G	E	U	U	E
Hydraulic Oils	F	G	E	E	E	E	-	-	G	F	E	E	U	U	G

* See material trademark note on page 32.

BUTTERFLY VALVES MATERIAL SELECTION GUIDE (Continued)

APPLICATION E - Excellent
 CODE G - Good
 F - Fair
 U - Unsatisfactory

Nickel Plated Ductile Iron
 416 SS
 316 SS
 Monel+
 Aluminum Bronze
 Alloy 20
 Hastelloy C+
 PVF
 Stem & Disc
 BUNA-N
 Neoprene
 Hypalon+
 FKM
 EPDM
 Natural Rubber
 ETM-30230
 Seat

APPLICATION	Nickel Plated Ductile Iron	416 SS	316 SS	Monel+	Aluminum Bronze	Alloy 20	Hastelloy C+	PVF	BUNA-N	Neoprene	Hypalon+	FKM	EPDM	Natural Rubber	ETM-30230
Hydrobromic Acid 200°F	U	U	U	U	U	U	E	E	U	U	E	E	E	E	-
Hydrochloric Acid 10% 60°F	U	U	U	F	U	U	E	E	F	G	G	E	G	-	-
Hydrochloric Acid 20% 60°F	U	U	U	U	U	U	E	E	F	G	G	E	-	-	-
Hydrochloric Acid 35% 60°F	U	U	U	U	U	U	G	G	F	G	G	E	-	-	U
Hydrocyanic Acid	U	-	G	F	U	E	E	E	G	G	E	E	G	G	-
Hydrofluoric Acid 48%	U	F	U	F	U	F	E	E	U	U	E	E	-	-	-
Hydrofluoric Acid 60%	U	U	U	U	U	F	E	E	G	U	G	G	E	G	-
Hydrofluoric Acid 100%	U	U	U	U	U	F	E	E	U	U	U	F	-	-	-
Hydrofluosilicic Acid 5% 70°F	U	G	G	G	E	G	E	G	G	G	E	E	E	E	-
Hydrogen	F	G	E	E	F	E	-	E	E	E	E	E	E	G	-
Hydrogen Peroxide 90%	U	F	G	G	U	G	E	E	U	U	G	G	F	U	G
Hydrogen Sulfide-Dry	F	F	E	G	F	G	E	E	F	-	G	G	E	G	G
Hydrogen Sulfide-Wet	F	F	G	F	F	E	-	E	-	-	G	G	G	U	F
Iodine Solution	U	U	U	U	U	U	E	E	F	U	G	E	G	F	-
Iso-Octane	F	E	E	E	E	E	E	E	E	G	G	E	U	U	G
Isopropyl Alcohol	F	E	E	E	E	E	E	-	G	F	E	E	E	E	G
Isopropyl Ether	F	E	E	E	E	E	E	-	G	F	F	U	U	U	-
Kerosene	E	E	E	E	E	E	E	E	E	G	U	E	U	U	E
Lacquer Solvents	F	E	E	E	E	E	E	-	U	U	U	U	U	U	U
Lactic Acid 5% 70°F	U	F	G	G	U	E	E	U	G	E	E	E	G	G	-
Lard Oil 70°F	G	-	E	G	G	E	E	E	E	F	U	E	U	U	E
Lemon Oil	U	F	E	E	E	E	E	E	G	F	-	-	-	-	-
Linseed Oil	F	E	E	E	E	E	E	E	E	G	G	E	U	-	-
Lubricating Oil	E	E	E	E	E	E	E	E	E	F	G	E	U	U	E
Magnesium Chloride 4% 75°F	F	F	G	G	F	E	E	E	E	E	E	E	E	E	E
Magnesium Hydroxide	F	E	E	G	G	E	-	E	G	E	E	E	E	G	G
Magnesium Sulphate 5% 120°F	F	G	E	E	E	E	E	E	E	E	E	E	E	G	E
Mecuric Chloride 3% 60°F	U	U	F	U	U	F	E	E	E	E	E	E	E	E	E
Mecuric Cyanide	U	-	E	U	U	E	E	F	G	F	F	G	-	F	-
Mercurous Nitrate (pH7+)	U	-	G	U	U	E	E	E	F	F	-	-	-	-	-
Mercury	E	E	E	E	U	E	E	E	E	E	E	E	E	E	E
Methyl Acetate	F	G	E	-	-	E	-	-	U	U	U	U	G	U	U
Methyl Acetone	F	E	E	-	E	E	-	-	U	U	U	-	-	U	-
Methyl Cellosolve	F	E	E	E	E	E	-	E	U	U	U	U	G	U	-
Methyl Chloride	G	G	E	G	E	E	-	E	U	U	U	G	F	U	-
Methyl Ethyl Ketone (MEK)	E	E	E	-	E	E	-	U	U	U	U	E	E	U	U
Milk (Food)	U	U	E	F	U	E	E	E	E	E	-	E	U	-	-
Mineral Oil	F	-	E	E	G	E	E	E	E	G	G	E	U	U	E
Molasses (Food)	U	U	E	-	U	E	-	G	-	E	-	-	E	-	-
Naphtha	F	E	E	G	G	E	E	E	G	U	U	E	U	U	G
Naphthalene	F	E	E	G	G	E	-	E	U	U	U	E	U	U	-
Natural Gas (Methane)	G	E	E	-	E	E	-	-	E	E	E	E	U	F	E
Nickel Ammonium Sulphate	U	-	E	F	U	-	-	-	-	E	-	-	-	-	-
Nickel Chloride	U	-	G	G	U	G	E	E	E	E	E	E	E	E	-
Nickel Sulphate 10% 60°F	U	-	E	G	G	E	E	E	E	E	E	E	E	G	-
Nitric Acid 10% 70°F	U	-	G	U	U	G	G	U	U	G	E	E	G	U	U
Nitric Acid 30% 70°F	U	-	G	U	U	G	G	U	U	F	E	E	G	U	U
Nitric Acid 60% 175°F	U	-	G	U	U	G	G	U	U	U	U	E	U	U	U
Nitric Acid 70%	U	U	G	U	U	G	G	U	U	U	U	E	U	U	U
Nitrobenzene	U	-	E	G	-	E	-	F	U	U	U	G	U	-	U
Oils and Fats	E	E	E	G	E	E	-	-	E	-	-	U	U	-	E
Oils, Fish	U	G	E	-	F	E	-	-	G	E	F	U	U	-	E
Oleic Acid 100°F	U	F	G	G	G	E	E	E	F	G	G	G	-	U	G
Oleum (Fuming Sulfuric Acid)	U	U	F	-	-	G	G	-	U	U	U	E	U	U	U
Oxalic Acid	U	F	G	F	F	G	G	F	G	G	G	E	G	G	F
Oxygen	E	E	E	E	E	E	-	E	G	E	E	E	E	-	G
Ozone	U	G	E	-	-	-	-	E	U	F	E	E	E	U	G
Palmitic Acid	U	G	E	G	G	E	-	E	E	G	F	G	G	F	G
Perchloroethylene	F	G	E	G	G	E	-	E	F	U	U	E	U	U	F
Petroleum-Refined	G	-	E	E	E	-	-	E	E	G	E	E	U	U	E
Petroleum-Sour	U	G	G	G	F	G	E	E	F	-	E	G	U	-	G
Phenol	U	-	E	E	G	E	E	E	U	U	U	G	-	U	F
Phosgene	-	-	E	-	-	-	-	-	G	U	U	G	U	U	-
Phosphoric Acid 10% 70°F	U	F	G	F	U	G	E	E	G	G	G	E	G	F	-
Phosphoric Acid 25% 70°F	U	U	G	F	U	G	G	E	F	G	G	E	E	U	-
Phosphoric Acid 75% 70°F	U	U	G	F	U	-	F	E	U	G	G	G	E	U	-
Phosphorous Oxychloride	U	-	-	-	-	-	-	-	-	-	-	-	-	-	-
Pickling Sol. (20% Nitric-4% HF)	U	-	G	G	-	-	-	-	U	U	U	G	F	U	U
Picric Acid 80% 70°F	U	-	G	U	-	E	E	E	G	E	E	G	E	G	-
Polyethylene Glycol Dimethyl Ether (Selexol)	-	-	-	-	-	-	-	-	-	-	-	U	G	U	-
Potassium Chloride	U	-	G	G	E	E	-	E	E	E	E	E	E	E	E
Potassium Cyanide	F	G	G	G	U	E	-	E	E	E	E	E	E	E	E
Potassium Hydroxide 5% 70°F	F	G	E	E	U	E	E	G	E	G	E	G	E	G	-
Potassium Nitrate 6% 68°F	F	G	E	G	F	E	E	E	E	E	G	E	E	E	E

BUTTERFLY VALVES MATERIAL SELECTION GUIDE (Continued)

APPLICATION CODE	Stem & Disc								Seat						
	Nickel Plated Ductile Iron	416 SS	316 SS	Monel+	Aluminum Bronze	Alloy 20	Hastelloy C+	PVF	Buna-N	Neoprene	Hypalon+	FKM	EPDM	Natural Rubber	ETM-30230
Potassium Phosphate	U	-	G	G	F	-	-	-	E	E	-	E	-	-	-
Potassium Sulphate 7% 180°F	F	G	E	E	E	E	-	E	E	E	G	E	E	-	E
Potassium Sulfide	U	G	E	F	U	E	-	E	E	G	G	G	G	G	-
Potassium Sulfite	U	-	E	-	-	E	-	-	E	G	G	E	E	G	-
Propane	F	E	E	E	E	E	-	E	E	G	G	E	U	U	E
Resins and Rosins	U	E	E	G	E	E	E	-	F	F	F	E	-	F	-
SAE #10 Oil	G	-	-	-	E	-	-	-	E	-	E	E	U	-	E
Sea Water 70°F	U	F	G	E	E	G	E	E	E	E	E	G	E	F	-
Sewage	U	G	E	G	G	E	-	E	E	E	E	E	G	F	-
Silicate Ester Synthetic Oil	-	-	-	-	-	-	-	-	-	G	E	E	U	-	-
Skydrol 500	G	E	E	-	E	E	-	-	U	U	U	U	E	U	U
Soap Solution (Stearate) 70°F	U	F	E	E	E	E	E	E	E	E	E	E	E	F	E
Sodium Acetate 5% 75°F	U	F	E	G	G	E	E	E	G	G	U	U	E	E	-
Sodium Aluminate	U	-	E	G	G	E	-	-	E	E	G	E	G	G	-
Sodium Bisulfate	U	F	E	-	-	E	-	E	E	E	E	E	E	E	E
Sodium Carbonate 80% 60°F	U	G	E	E	G	E	E	E	E	E	E	E	E	E	E
Sodium Chloride 30% 180°F	U	F	E	E	E	E	E	E	E	E	E	E	E	E	E
Sodium Cyanide	U	-	G	U	U	E	-	E	E	E	E	E	E	E	-
Sodium Fluoride 5% 60°F	U	-	G	G	F	-	E	E	E	E	G	E	G	G	-
Sodium Hydroxide 5%	U	G	E	G	F	E	E	G	G	F	E	G	E	E	-
Sodium Hydroxide 20%	U	F	E	E	F	E	E	G	G	U	E	G	E	E	-
Sodium Hydroxide 50%	U	F	G	G	U	E	E	E	G	U	G	F	G	G	-
Sodium Hydroxide 70%	U	U	F	F	U	G	G	G	F	U	U	U	G	F	-
Sodium Hypochlorite 5% 60°F	U	-	G	G	U	G	E	E	F	U	E	E	G	F	G
Sodium Nitrate 30% 60°F	U	G	E	G	G	E	E	E	G	G	E	E	E	G	G
Sodium Perborate	U	G	G	G	G	-	-	-	G	G	G	E	E	G	-
Sodium Peroxide	U	G	E	G	U	-	-	E	G	G	G	E	E	G	-
Sodium Phosphate 5% 60°F	U	G	E	G	F	E	E	E	E	G	E	E	E	E	U
Sodium Silicate	U	G	E	G	G	E	E	E	E	E	E	E	E	E	-
Sodium Sulphate 80% 60°F	U	G	E	G	G	E	E	E	E	E	E	E	E	G	E
Sodium Sulfide 70% 70°F	U	G	E	-	-	E	E	E	E	E	E	E	E	G	-
Sodium Sulfite 5% 70°F	U	-	E	G	U	E	E	E	E	E	E	E	E	G	-
Steam 225°F	U	U	E	E	E	-	-	-	U	U	U	U	G	U	U
Steam 300°F	U	U	E	E	G	-	-	-	U	U	U	U	U	U	U
Stearic Acid 90% 200°F	U	G	E	G	F	E	E	E	G	G	G	E	G	G	F
Steep Water	-	-	-	-	-	-	-	-	-	-	G	G	-	U	-
Styrene (Fumes)	-	-	E	-	-	-	-	-	U	-	-	G	U	-	-
Sulfamic Acid	-	-	-	-	-	E	-	E	-	-	E	-	G	-	-
Sulphur (Molten)	U	F	G	U	U	E	E	-	U	F	U	G	F	U	F
Sulphur Dioxide 60°F	U	G	E	E	F	E	E	E	U	G	F	E	E	G	-
Sulphur Trioxide	U	G	E	-	-	E	E	-	U	U	U	E	G	G	-
Sulfuric Acid 0-7% 70°F	U	F	G	F	U	E	E	E	U	G	E	E	U	U	F
Sulfuric Acid 7-40% 70°F	U	U	U	U	U	G	G	E	U	U	E	E	U	U	-
Sulfuric Acid 40-75% 70°F	U	U	U	U	U	G	G	E	U	U	G	G	U	U	-
Sulfuric Acid 75-95%	U	U	U	U	U	U	G	E	U	U	U	G	U	U	-
Sulfuric Acid 95-100%	U	U	U	U	U	U	E	E	U	U	G	G	U	U	U
Sulfurous Acid 80% 100°F	U	U	G	F	U	E	E	G	U	U	E	E	U	-	-
Tall Oil	G	G	E	G	-	E	-	E	G	G	-	E	-	E	-
Tannic Acid 150°F	U	F	E	G	G	E	E	G	E	G	G	E	E	E	F
Tar	F	E	E	E	E	E	E	-	F	F	-	E	U	U	F
Tartaric Acid 150°F	U	G	E	G	G	E	E	G	G	G	E	E	G	E	F
Toluol and Toluolene	G	E	E	-	E	E	-	G	U	U	U	E	U	U	U
Toluene Sulfonic Acid	-	-	U	-	-	-	-	U	-	-	-	G	-	-	-
Transformer Oil	-	-	-	-	-	-	-	-	U	-	-	E	U	-	-
Tributyl Phosphate	G	F	E	-	-	E	-	E	U	U	U	U	E	G	-
Trichloroacetic Acid	U	U	U	G	G	-	-	F	G	U	U	F	G	F	-
Trichloroethylene	F	U	E	G	G	E	-	G	U	U	U	E	U	U	U
Triethinolamine	U	U	E	G	-	-	-	G	F	E	E	U	G	G	-
Trisodium Phosphate	U	U	G	G	F	-	-	E	F	F	-	-	-	-	-
Tung Oil	U	U	E	F	E	E	E	-	E	G	G	E	U	U	-
Turpentine	U	U	E	G	G	-	-	E	G	U	U	E	U	U	F
Vinegar 70°F	U	-	E	E	-	E	E	G	G	G	E	E	E	G	-
Water, Acid-Mine	U	-	E	U	-	E	E	G	F	F	E	E	F	F	-
Water-Deionized	-	-	E	-	-	-	-	E	E	-	E	-	E	-	-
Water-Demineralized	U	-	E	E	E	E	-	E	E	E	E	E	E	F	-
Water-Fresh 180°F	G	E	E	E	E	E	E	E	G	G	F	U	E	U	F
Water-Fresh 225°F	G	E	E	E	E	E	E	E	U	U	U	U	E	U	-
Water-salt 180°F	U	U	G	E	G	E	E	E	G	G	F	U	E	U	-
Water-Sewage 80°F	U	G	E	E	E	E	E	-	E	-	-	E	E	-	-
Whiskey and Wine	U	U	E	E	G	E	E	E	E	E	G	E	E	-	-
White Liquor	U	-	E	-	-	E	E	-	G	-	G	-	-	F	-
Xylene, Xylol	F	E	E	-	E	E	-	E	U	U	U	E	U	U	U
Zinc Chloride 5% 160°	U	U	F	G	U	G	G	E	E	E	E	E	E	E	-
Zinc Phosphate	-	-	G	-	-	-	-	E	E	-	-	-	E	-	-
Zinc Sulphate 25% 180°F	U	G	E	G	G	E	E	E	E	E	E	E	E	G	-

* See material trademark note on page 32.

TRADEMARK INFORMATION

DEMCO® is a registered trademark which is owned by Cameron.

This document contains references to registered trademarks or product designations, which are not owned by Cameron.

Trademark	Owner
CELCON	Hoechst Celanese Corporation
DELFIN	E.I. DuPont De Nemours & Company
FLUOREL	Minnesota Mining and Manufacturing Company
HASTELLOY	Haynes International, Inc.
HYCAR	Hydrocarbon Chemical and Rubber Company
HYDRIN	Zeon Chemicals USA, Inc.
HYPALON	E.I. DuPont De Nemours & Company
INCONEL	INCO Nickel Sales, Inc.
MONEL	INCO Alloys International, Inc.
NORDEL	E.I. DuPont De Nemours & Company
STELLITE	Stoody Deloro Stellite, Inc.
TEFLON	E.I. DuPont De Nemours & Company

