



Cartridges & Manifolds



SAE Encapsulated Cartridge

- Meets Performance Requirements of D.O.T. FMVSS 571.106
- Meets Proposed Dimensional Standards of SAE J2494-4 in 6061-T6 Aluminum
- Eliminate the space and labor costs associated with pipe threads.
- Weight Reduction
- 3 barb design



Prestomatic Removable Tank Cartridge





- Meets Performance Requirements of D.O.T. FMVSS 571.106
- Meets SAE J1131 Requirements
- Double O-ring Seal



Manifolds

- Meets Performance Requirements of D.O.T. FMVSS 571.106
- Light Weight Body
- Push to Connect Ports
- O-ring Seal

The World Standard

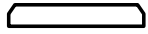
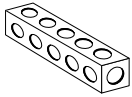
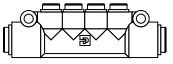
Cartridges	<p>PMCEN-ES Encapsulated Cartridge Replaceable Button</p>  <p>Page J7</p>	<p>PMT CER-ES Encapsulated Cartridge Removeable Collet & O-Ring</p>  <p>Page J7</p>	<p>PMTCE SAE Encapsulated</p>  <p>Page J4</p>	<p>TCPR Removable Tank Cartridge</p>  <p>Page J10</p>			
	Auxiliary	<p>ES External Seal</p>  <p>Page J7</p>	<p>PMB Removable Button</p>  <p>Page J7</p>				
	Manifolds	<p>255MP Brass Manifold</p>  <p>Page J11</p>	<p>24M Composite Manifold</p>  <p>Page J12</p>				

J

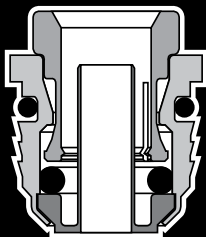

Prestomatic SAE Encapsulated Cartridges

Advantages

Parker Prestomatic[†] SAE Encapsulated Cartridges are a compact, economical design that allows the user to eliminate the space and labor required to install and assemble a conventional pipe thread fitting connection. Weight reduction and the elimination of pipe thread leakage related to improper assembly techniques are achieved. The SAE Cartridge design allows for faster and easier installation of components and assemblies. The SAE Cartridge is retained in the cavity by 3 barbs versus the normal 2 barbs for better performance over a wider diameter tolerance range. The external o-ring seals radially and does not require special chamfers at the top of the cavity to effect a seal. The SAE Cartridge includes a built in tube support. Once the SAE Cartridge is installed in a single step cavity, no special tools are needed for tube assembly. Just bottom the tubing into the cartridge body for a positive seal.

Materials

Parker's Prestomatic SAE Encapsulated Cartridges have been developed for both soft metal and plastic cavity applications. Consult factory for specific cavity or housing materials that would be suitable for a particular application.

Specifications

Cavity dimensions are per the proposed SAE Standard J2494-4. The Prestomatic SAE Encapsulated Cartridge is thoroughly tested to meet or exceed the performance requirements of DOT FMVSS 571.106 and SAE J1131 and the proposed dimensional standards of SAE J2494-4 in 6061-T6 aluminum. Cavity dimensions specified by SAE J2494-4 need to be adjusted slightly for optimum performance in material other than 6061-T6.

Technical Data

- Working pressure from vacuum to 250 psi
- Working temperature from -40°F to +200°F (Note: See tubing manufacturer's recommendations for pressure and temperatures limitations.)

Features

- Easy assembly
- Patented third generation Prestomatic^{*} brass componentry which includes a shoulder for increased side load capabilities, contamination resistance features and tight internal tolerances for a close fit and smooth operation.
- Available in tube sizes 5/32** 1/4", 3/8", 1/2", 5/8" and 3/4"
- Available in elbows and straight configurations
- Built in Brass tube support assures maximum flow and performance characteristics

**DOT only

[†] U.S. Patent No. 5,683,120

Tube Assembly Instructions

1. Cut Parker Parflex thermoplastic squarely using Parker tube cutter PTC-001. Metal tubing should be cut square and free of burrs.
2. Insert end of tubing into cartridge until it bottoms. Pull on tubing to verify it is properly retained
3. To disassemble, simply hold release button against the body and remove tubing
4. To reassemble, lubricate leading end of tubing with light oil or petroleum jelly

Order

By part number and name

Nomenclature

Part numbers are constructed from symbols that identify the style and size of the cartridge

Example:

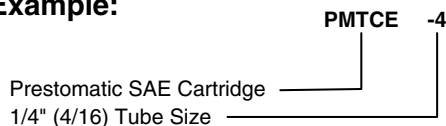

Special Cartridges

Encapsulated cartridge configurations and /or sizes other than those shown in the catalog can be furnished. Non-standard o-ring materials are available. It is suggested that a print or sketch be submitted with the inquiry. Price and delivery for non-stock items furnished on request for specified quantities.



Prestomatic SAE Encapsulated Cartridge PMCE/PMTCE

PART NO.	TUBE SIZE	CAVITY SIZE ±.002	L	M	O.D.	FLOW DIA. D
PMCE-5/32	5/32	.346	.57	.43	.44	.125
PMTCE-4	1/4	.504	.64	.44	.56	.140
PMTCE-4-8	1/4	.775	.66	.42	.87	.140
PMTCE-6	3/8	.650	.84	.64	.75	.217
PMTCE-6-8	3/8	.775	.84	.64	.87	.217
PMTCE-8	1/2	.775	.98	.77	.87	.338
PMTCE-10	5/8	.925	1.07	.86	1.00	.398
PMTCE-12	3/4	1.067	1.12	.93	1.19	.503

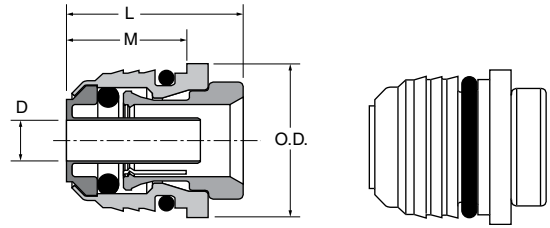

Installation

Apply force evenly over the top surface of the cartridge body until the cartridge shoulder bottoms out on the top of the cavity. The amount of force required will vary depending on the cartridge size and the material of the cavity.

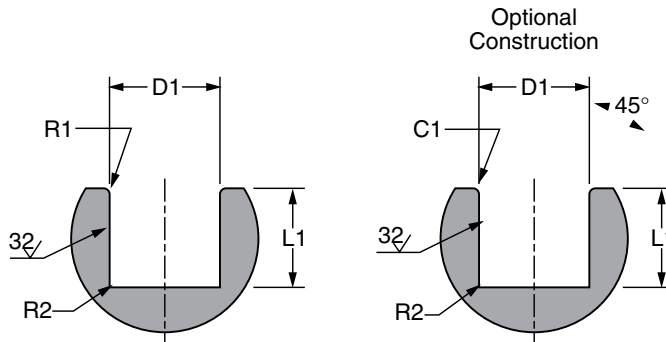
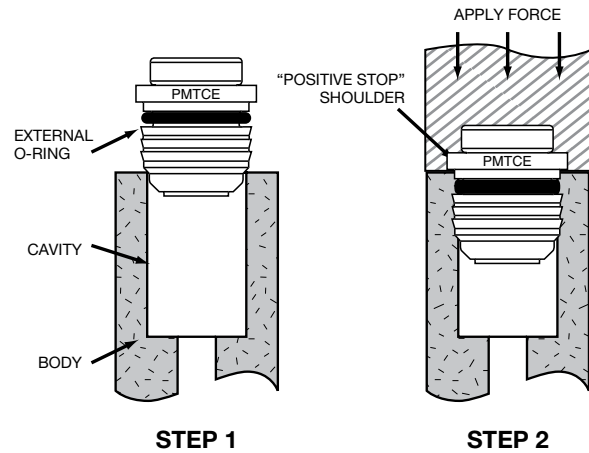

Nominal Tube OD (in)	D1 (mm) ±.05	D1 (in) ±.002	L1 (mm) MIN	L1 (in) MIN	R1 (mm) ±.05	R1 (in) ±.002	R2 (mm) ±.05	R2 (in) ±.002	C1 (mm) ±.05	C1 (in) ±.002
5/32	8.80	.346	11.40	.45	.50	.02	.50	.02	.50	.02
1/4	12.80	.504	12.70	.50	.50	.02	.50	.02	.50	.02
3/8	16.50	.650	16.50	.65	.50	.02	.50	.02	.50	.02
1/2	19.70	.775	19.80	.78	.50	.02	.50	.02	.50	.02
5/8	23.50	.925	22.40	.88	.80	.03	.50	.02	.80	.03
3/4	27.10	1.067	23.90	.94	.80	.03	.50	.02	.80	.03

Cavity material is to be 6061 T6 aluminum

† U.S. Patent No. 5,683,120

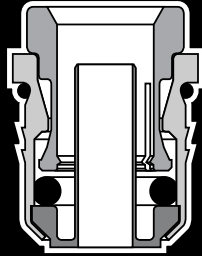

Presto Encapsulated Cartridges

Advantages

Parker Presto Encapsulated Cartridges are a compact, economical design that allows the user to eliminate the space and labor required to install and assemble a conventional pipe thread fitting connection. Weight reduction and the elimination of pipe thread leakage related to improper assembly techniques are also improved. The Presto Cartridge design allows for faster and easier installation of components and assemblies. An external o-ring is included assembled to the Presto Cartridge to insure a leak free cavity. The PMTCER includes a built in tube support. Once the Presto Cartridge is installed in a single step cavity, no special tools are needed to assemble. Just bottom the tubing into the cartridge body for a positive seal. For color coding use the PMCEN cartridge. After installation into a cavity, simply snap on the color coded release button onto the PMCEN Cartridge. The PMTCER requires no additional button assembly.

Materials

Presto Encapsulated Cartridges are designed to be installed into a thermoplastic (Nylon/Glass Filled Nylon/Acetal) cavity. Consult factory for specific cavity or housing materials that would be suitable for a particular application.

Applications Industrial (PMCEN, PMTCER)

Once the Presto Encapsulated Cartridge is installed into an approved cavity material, use with Parker Parflex series "E" polyethylene tubing, series "N" nylon tubing, series "U" polyurethane tubing or soft metal tubing in pneumatic instrumentation circuits and various industrial applications.

Air Brake (PMCEN)

For Air Brake applications, use with Parker Parflex SAE J844 Type A and B nylon tubing. Sizes 5/32" and above meet D.O.T. FMVSS 571.106 air brake performance specifications. The addition of a stainless steel tube support (63 NTA) in sizes 1/4" and above assures that the cartridge assembly will meet the performance requirements of SAE J1131 and D.O.T. FMVSS 571.106. Consult factory for specific cavity or housing material to insure cartridge to cavity assembly will meet SAE J1131 requirements. 1/8" Presto Encapsulated Cartridges are designed for use in pressure protected air accessory lines that are isolated from the air brake system.

Air Brake (PMT CER)

For Air Brake applications use with Parker Parflex SAE J844 Type A&B nylon tubing. PMTCER cartridges with a built in tube support meet performance requirements of D.O.T. FMVSS 571.106 and SAE J1131.

Technical Data

- Working pressure from vacuum to 250 PSI
- Working temperature from -40°F to +200°F (Note: See tubing manufacturer's recommendations for pressure and temperature limitations. Check working temperature of manifold material)
- Buna N (nitrile) O-Rings

Tube Assembly Instructions

1. Cut Parker Parflex thermoplastic squarely using Parker tube cutter PTC-001. Metal Tubing should be cut square and free of burrs.
2. Insert end of tubing into cartridge until it bottoms. Pull on tubing to verify it is properly retained.
3. To disassemble, simply hold release button against the body and remove tubing.
4. To reassemble, lubricate leading end of the tubing with light oil or petroleum jelly.

Order

By part number and name.

Nomenclature

Part numbers are constructed from symbols that identify the style and size of the cartridge. Presto Encapsulated Cartridge buttons for the PMCEN are to be ordered separately from the cartridge and specified by color.

Example:

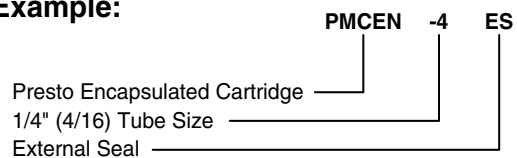

Special Cartridges

Encapsulated cartridge configurations and/or sizes other than those shown in the catalog can be furnished. Non-standard o-ring materials available. It is suggested that a print or sketch be submitted with the inquiry. Price and delivery for non-stock items furnished on request for specified quantities.

PMCCN Features

No tube support required to pass performance requirements of D.O.T. FMVSS 571.106 (PMCCN-532 & larger)

Low profile tube connections are the same height for all sizes, simplifying multiple tube size installations.

External seal

External barb design improves sealing capability.

Positive tube stop. Tube insertion depth is consistent with Prestomatic fittings.

Increased flow diameter due to elimination of tube support.

Housing

Inside Cavity

Optional color coded release buttons can be removed to prevent accidental release of tubing

Collet designed to prevent side load leakage

"Positive stop" shoulder insures that cartridges are installed to the proper depth

Encapsulated o-ring eliminates concerns for out-of-round cavity and damage during shipment

Self-aligning design allows for consistent installation.

Single diameter cavity

Chamfer required for external seal

- Working pressure: Vacuum to 250 psi (See tubing manufacturer's recommendations for pressure and temperature limitations.)
- Temperature Range: -40°F to 200°F
- Optional o-ring materials are available
- Fewer components to inventory
- Encapsulated design eliminates the accidental omission of components during cartridge installation.
- Color coding available
- No threads to leak resulting from improper assembly.
- No thread sealants to contaminate air system

PMTCER Features

Passes performance requirements of D.O.T. FMVSS 571.106 SAE J1131 in size 1/4" and above

Low profile tube connections are the same height for all sizes, simplifying multiple tube size installations.

External seal

External barb design improves sealing capability.

Positive tube stop. Same insertion depth as fitting

Plastic cavity

No special surface finished required.

Integrated button cannot be separated from cartridge.

Collet designed to eliminate side load leakage and is removable for o-ring replacement.

"Positive stop" shoulder insures that cartridges are installed to the proper depth

Tube support is machined concentric to cartridge. Cannot interfere with tube insertion nor can it be dislodged or removed.

Encapsulated replaceable o-ring eliminates concerns for out-of-round cavity and leaks due to damaged o-rings.

Self-aligning design allows for consistent installation.

Single diameter cavity

Chamfer required for external seal

- Working pressure: Vacuum to 250 psi (See tubing manufacturer's recommendations for pressure and temperature limitations.)
- Temperature Range: -40°F to 200°F
- Optional o-ring materials are available
- Fewer components to inventory
- Encapsulated design eliminates the accidental omission of components during cartridge installation.
- One piece button collet
- No threads to leak resulting from improper assembly.
- No thread sealants to contaminate air system



Encapsulated Cartridge PMCEN-Replaceable Button (PMB listed below)

PART NO.	TUBE SIZE	L	H	O.D.	FLOW DIA. D
PMCEN-5/32ES	5/32	.59	.18	.406	.125
PMCEN-4ES	1/4	.62	.18	.500	.188
PMCEN-6ES	3/8	.81	.18	.750	.312

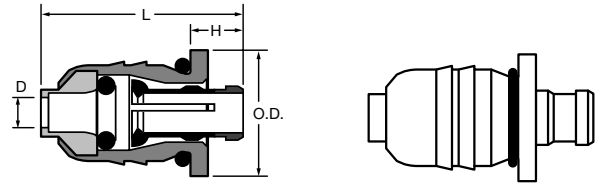

Encapsulated Cartridge PMTCER-Removeable Collet and O-ring

PART NO.	TUBE SIZE	L	H	O.D.	FLOW DIA. D
PMT CER-4ES	1/4	.65	.21	.500	.138
PMT CER-6ES	3/8	.84	.21	.750	.215

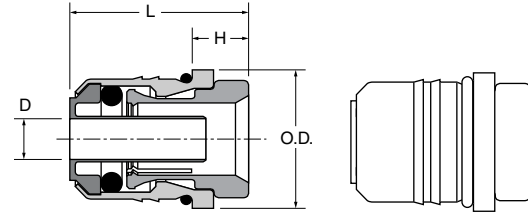

External Seal ES*

PART NUMBER	TUBE SIZE	I.D.	W
ES-2†	1/8	.283	.040
ES-4	1/4	.390	.040
ES-6	3/8	.585	.060

*Material is Nitrite (Buna N), 70 Durometer
 † Note: ES2 is to be used with PMCEN-5/32

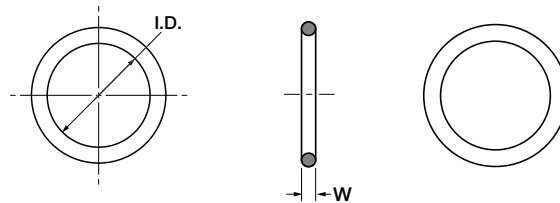

Removable Cartridge Button PMB

PART NUMBER	TUBE SIZE	O.D.	L
5/32PMB-X	5/32	.335	.109
4PMB-X	1/4	.460	.109
6PMB-X	3/8	.710	.109

Specify Color When Ordering,
 Example: 4PMB-BU
 Colors Available:
 BU-Blue G-Green O-Orange
 P-Purple R-Red Y-Yellow
 W-White BL-Black GY-Gray

Note:
 4PMB not available in W

For PMCEN Cartridges only

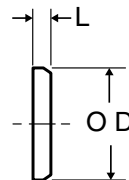

Cartridge Dimensions

TUBE SIZE	A	B	C DIA.	H DIA.	J
5/32	.18	.21	.406	.21	.10
3/16	.18	.21	.437	.24	.10
1/4	.18	.21	.500	.31	.10
3/8	.18	.21	.750	.43	.10

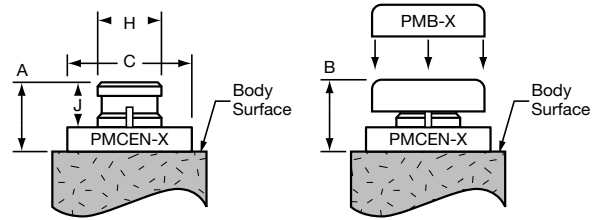

Cavity Dimensions

for use with glass filled nylon and acetal

TUBE SIZE	E DIA. ± .002	F DIA. ± .002	G DIA. MIN.	D MIN.
5/32	.326	.358	.125	.43
3/16	.357	.389	.156	.43
1/4	.433	.465	.188	.46
3/8	.648	.696	.312	.65

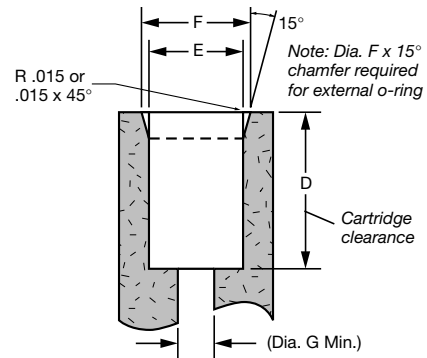

PMCEN Cartridge Installation Instructions

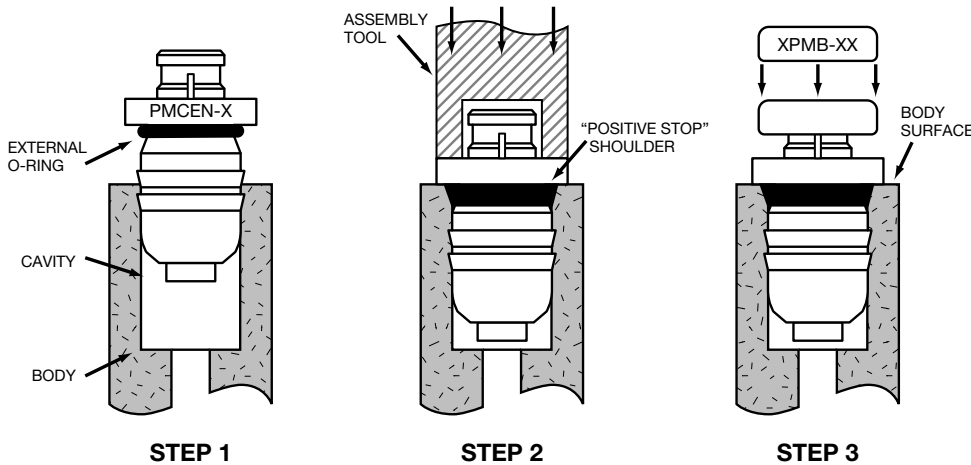

PMT CER Cartridge Installation Instructions

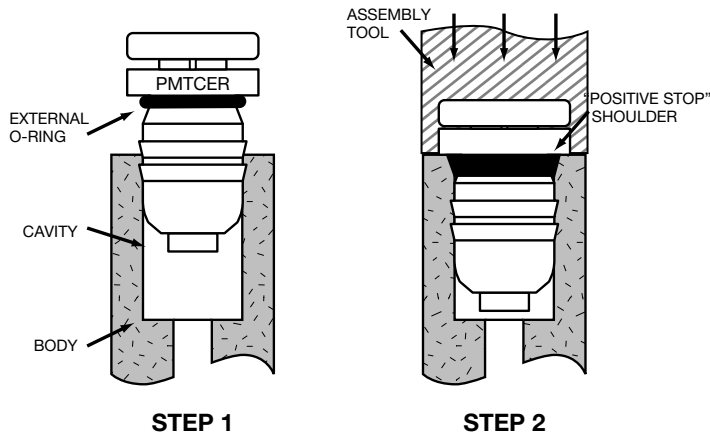

J

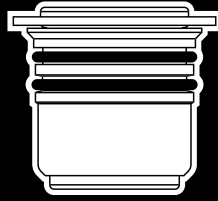

Prestomatic Removable Tank Cartridges

Advantages

Leakage and assembly problems encountered with the use of pipe threaded fittings in out-of-round internal threads that are commonly found in air tank spuds prompted the development of the Prestomatic[†] Removal Tank Cartridge. This threadless cartridge is retained in the spud by a standard retaining ring, and the double Buna-N (Nitrile) o-ring seal virtually guarantees leak free performance.

Specifications

The Prestomatic removable tank cartridge has been thoughtfully tested and meets or exceeds the requirements of DOT FMVSS 571.106 and SAE J1131.

Technical Data

- Working pressure from vacuum to 250 psi
- Working temperature from -40°F to +200°F (Note: See tubing manufacturer's recommendations for pressure and temperatures limitations.)

Features

- Easy assembly
- Patented third generation Prestomatic[®] brass componentry which includes a shoulder for increased side load capabilities, contamination resistance features and tight internal tolerances for a close fit and smooth operation
- Available in sizes 3/8", 1/2", 5/8" and 3/4"
- Available in straight and elbow configurations

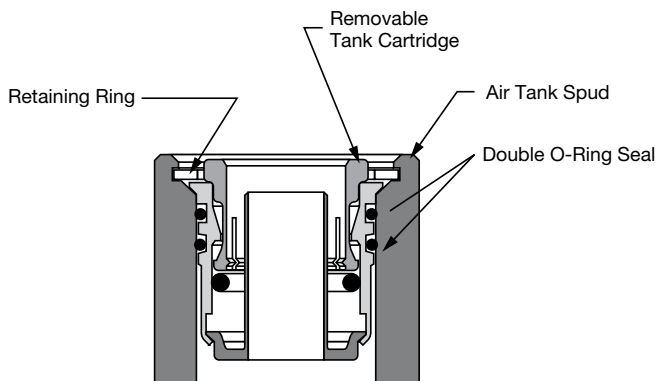

Tube Assembly Instructions

1. Cut Parker Parflex thermoplastic squarely using Parker tube cutter PTC-001.
2. Insert end of tubing into cartridge until it bottoms. Pull on tubing to verify it is properly retained
3. To disassemble, simply hold release button against the body and remove tubing

Order

By part number and name

Nomenclature

Part numbers are constructed from symbols that identify the style and size of the cartridge.

Example:

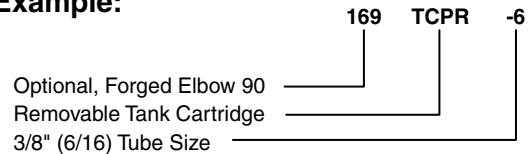

Special Cartridges

Configurations and /or sizes other than those shown in the catalog can be furnished. Non-standard o-ring materials are available. It is suggested that a print or sketch be submitted with the inquiry. Price and delivery for non-stock items furnished on request for specified quantities.

J

Spud Port Requirements for the Removable Tank Cartridge

TUBE SIZE	A	B	C	D	L1	L CLEARANCE
3/8", 1/2"	1.062	1.130	.949	1.27	.58	See Cartridge Dimensions
5/8", 3/4"	1.314	1.396	1.100	1.60	.69	See Cartridge Dimensions

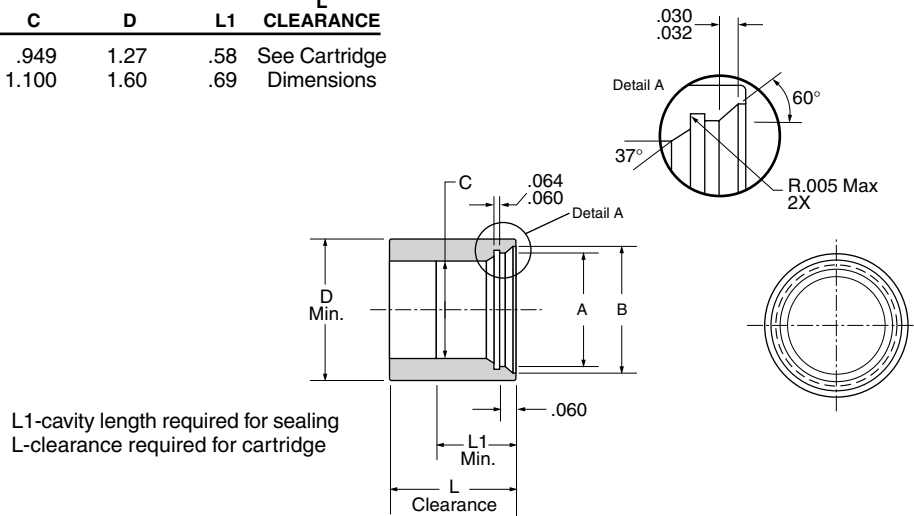

Prestomatic Removable Tank Cartridge TCPR

PART NO.	TUBE SIZE	RR*	L	N	FLOW DIA. D	L CLEARANCE
TCPR-6	3/8	HOI-106	.83	.93	.217	.62
TCPR-8	1/2	HOI-106	.97	.93	.338	.65
TCPR-10	5/8	HOI-131	1.05	1.08	.398	.75
TCPR-12	3/4	HOI-131	1.15	1.19	.500	.90

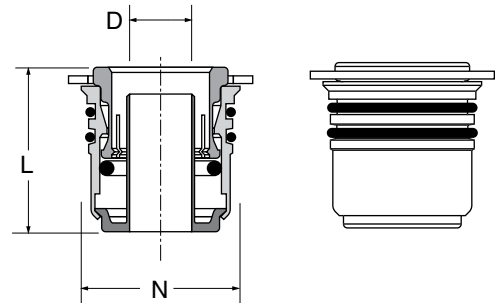

*Retaining ring required for assembly. Retaining ring is not supplied with cartridge. Retaining ring manufactured by Rotor Clip Company, Inc.

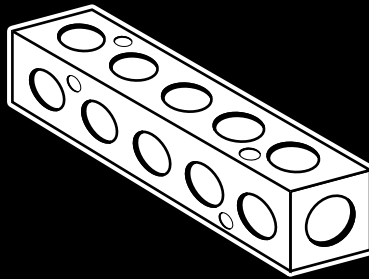

Brass Manifold

Advantages

Parker's Brass Manifold provides a convenient junction for the hook-up of multi-branch distribution lines. Porting is easy with five 1/8" and five 1/4" side ports. Two 3/8" inlet ports allow for maximum flow. Universal dual sided 7/32" mounting holes allow for easy manifold attachment.

Parker's all brass manifold can be readily identified, assuring high quality engineering and reliability. This economical manifold is machined from high quality CA360 brass.

Applications

May be used for air, water or hydraulic requirements. Specific applications include injection molders (coolant lines), packaging equipment, air logic systems (panel builders) and specialized industrial machinery requiring multiple line connections.

Temperature and Working Pressure Ranges

From -65° to +250°F at 1000 PSI maximum.

Nomenclature

Part numbers are constructed from symbols that identify the size and type of manifold. The first series of numbers and letters identifies the style and type fitting. The second series of numbers describes the size.

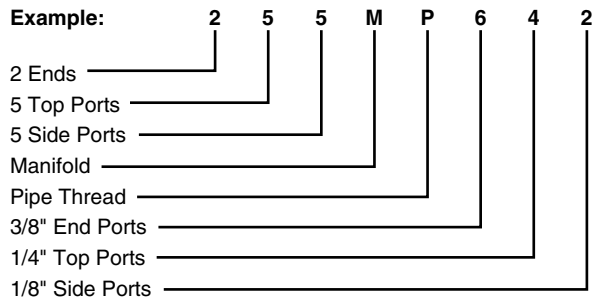

Special Manifolds

Manifold configurations and /or sizes other than our cataloged manifold can be furnished. It is suggested that a print or sketch be submitted with the inquiry.

Pricing

Price and delivery for non-stock items furnished on request for specified quantity.

Brass Manifold 255M

PART NO.	PIPE THREAD A	PIPE THREAD B	PIPE THREAD C	G	MOUNTING HOLE DIA. H	J	K	L	M	N	D
255MP-6-4-2	3/8	1/8	1/4	1.25	.22	.88	1.13	6.25	1.45	.25	.25

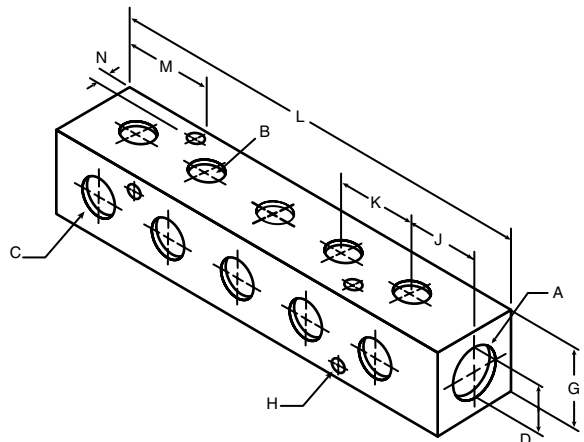

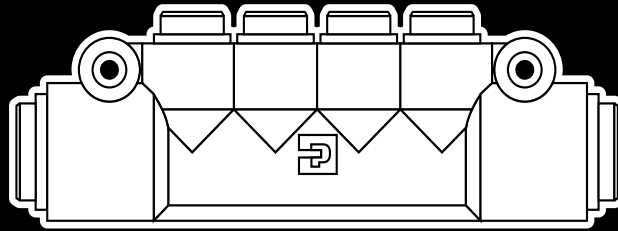

Presto Manifold

Advantages

Presto manifolds provide a convenient junction to connect multiple tubing lines for industrial and transportation applications. With their patented* tube retention design these manifolds meet all of the air brake performance specifications of D.O.T. FMVSS 571.106. The glass reinforced body is lightweight yet durable. Presto manifolds contain 1/4, 3/8 and 1/2 O.D. tube inlet and outlet ports to allow for design and application flexibility. No special tools are needed to assemble. Just bottom the tubing in the port for a positive seal.

Applications

Suitable for industrial or transportation applications requiring multiple branch connections using Parker Parflex series N Nylon for industrial applications, and Parker Parflex S.A.E. J844 type A & B nylon tubing for all transportation applications. Consult the factory with any questions regarding special product applications prior to use. All applications should be carefully tested through the range of conditions that may be encountered.

Technical Data

- Body Material: Glass Filled Nylon
- O-Ring Material: Buna N (Nitrile)
- Working Pressure from: Vacuum to 150 PSI
- Working Temperature from: -40° to 200° F
(Note: See tubing manufacturer's recommendation for pressure and temperature limitations).

Special Manifolds

Presto Manifold sizes other than those shown in the catalog can be formulated upon request. Die tooling charges may apply to non-standards. It is suggested that a print or sketch with specified buy quantities be submitted with the inquiry.

Assembly Instructions

1. Cut tubing squarely with Parker tube cutter PTC-001. Be certain that Manifold ports are clean and free of debris.
2. Insert tubing into port until it bottoms. Pull on tubing to verify that it is properly retained in the manifold.
3. To disassemble, simply hold release button against the manifold body and remove the tubing.
4. To reassemble, make certain that the Manifold ports are clean and free of debris and lubricate leading end of the tubing with light oil or petroleum jelly.

Order

By part number and name.

Nomenclature

Part numbers are constructed from symbols that identify the size and type of manifold. The first series of letters and numbers identify the style and type of manifold. The second series of numbers describe the tube O.D.

Example:

Presto Manifold 24M 6 4
 Inlet Tube O.D. (6/16)
 Outlet Tube O.D. (4/16)

Presto Manifold 24M

PART NO.	TUBE O.D. INLET	TUBE O.D. OUTLET	A	B	D	G	H	M	M1	N
24M-4-4	1/4	1/4	1.33	3.98	.21	2.75	.53	.90	.88	.89
24M-6-4	3/8	1/4	1.33	4.00	.21	2.75	.53	.90	.88	.89
24M-6-6	3/8	3/8	1.65	6.49	.22	4.55	.60	1.02	1.02	1.33
24M-8-8	1/2	1/2	1.65	6.49	.22	4.55	.60	1.02	1.02	1.33
24M-8-6446	1/2	3/8 - 1/4	1.65	6.49	.22	4.55	.64	1.02	1.02	1.17

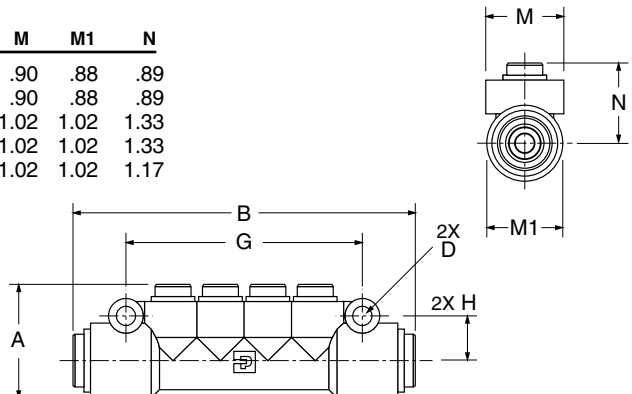

*U.S. Patent Number 5,683,120