



# DIAPHRAGM VALVES

Microelectronics Product Line

Catalog 4505/USA  
October 2003



# DIAPHRAGM VALVES

Microelectronics Product Line

Catalog 4508/USA  
October 2003

## table of contents

Veriflo Division . . . . .	1
SM917 1-1/8" . . . . .	2 - 3
SM930 1-1/8" & 1-1/2" . . . . .	4 - 7
SM955 1-1/2" . . . . .	8 - 11
930 . . . . .	12 - 15
930Y . . . . .	16 - 17
945 . . . . .	18 - 21
945Y . . . . .	22 - 23
955 . . . . .	24 - 25
955AOPLP . . . . .	26 - 27
955Y . . . . .	28 - 29
TITAN II AOP PLUS HP . . . . .	30 - 31
TITAN II AOP PLUS MP . . . . .	32 - 33
TITAN II AOP PLUS LP . . . . .	34 - 35
TITAN II MANUAL PLUS . . . . .	36 - 37
TITAN II Metal-Seal . . . . .	38 - 39
928AOPHP . . . . .	40 - 41
LockOut-TagOut . . . . .	42 - 43
VAC100 . . . . .	44 - 45
Parker Hannifin Corporation . . . . .	46



**Parker Hannifin Corporation**  
Veriflo Division  
250 Canal Boulevard  
Richmond, CA 94804-0034  
Telephone 510.235.9590  
Fax 510.232.7396  
<http://www.veriflo.com>



# VERIFLO DIVISION



**V**eriflo Division, Parker Hannifin Corporation is a leading manufacturer of precision valves, regulators and surface mount components for the control and application of liquids and gases used in the fabrication of semiconductors, as well as in the chemical and petrochemical industries.

## A Leading Manufacturer Of Precision Valves, Regulators & Surface Mount Components

Veriflo has maintained industry leadership over the past 95 years through innovative engineering, manufacturing and by placing a premium on quality customer care.



The division maintains two state-of-the-art Class 10 Clean Rooms at its Richmond, CA, facility and has adopted a corporate wide "Lean Manufacturing" philosophy, which is delivering greater value to the customer by eliminating wasteful steps through continuous improvement activities.

Veriflo Division's two manufacturing facilities develop and manufacture applications for the Semiconductor/High Purity and Instrument/Analyzer industries.

With the focus of maintaining the highest industry standards,



## Maintained Industry Leadership By Placing A Premium On Quality Customer Care

Veriflo Division has achieved an ISO 9001 registration at both its Richmond, CA manufacturing plant and at its Carson City, NV facility. This certification confirms Veriflo's commitment to quality and excellence as recognized by the international community.

The Instrumentation Group of Parker Hannifin specializes in high quality, critical flow components for world-wide process instrumentation, ultra-high-purity, medical, analytical and biopharmaceutical applications.

Parker's Instrumentation Group has ten manufacturing plants and over 300 authorized distributor locations around the world to provide local inventory and technical support. Key markets for the Instrumentation Group include: Chemical Process, Power Generation, Oil and Gas Exploration, Semiconductor Manufacturing, Biomedical, and Analytical Equipment.

*Note: For further information on Veriflo Division and or its product line visit the division web site at [www.veriflo.com](http://www.veriflo.com). For more information on Parker Hannifin Corporation visit the corporation's web site at [www.parker.com](http://www.parker.com).*

# SM917 1-1/8"

## Ultra High Purity Diaphragm Valve



Parker Hannifin Corporation's Veriflo Division presents the Surface Mount 917 1-1/8" Ultra High Purity Diaphragm Valves providing exceptional performance for today's modular surface mount systems.



### features

- ▶ 0.17  $C_v$  for AOP style or 0.15  $C_v$  for 1/4 turn manual style valves.
- ▶ "VeriClean", Veriflo's low sulfur high purity 316L Stainless Steel™, which enhances electropolishing, and corrosion resistance.
- ▶ Standard surface finish 5 micro inch Ra (.13 micro meter).
- ▶ Internally threadless and springless.
- ▶ Fully functional for pressure ranges from vacuum to 125 psig for Air Operated valves and 250 psig for manual valves.
- ▶ Change from air operated actuator to lever or visa versa without intruding into wetted area.
- ▶ 100% Helium leak tested.

### materials of construction

#### Wetted

Body . . . . . "VeriClean", Veriflo's custom high purity type 316L Stainless Steel™  
Seat . . . . . PCTFE, Optional VespeI® or PEEK™  
Diaphragm . . . . . Elgiloy® or equivalent

#### Non-wetted

Nut . . . . . Stainless Steel

### operating conditions

Maximum operating pressure:

AOP . . . . . 125 psig (8.6 barg)  
Manual . . . . . 250 psig (17.2 barg)

Minimum operating pressure . . . . . Vacuum

AOP Actuation . . . . . 75 psig (5 barg) nominal  
Temperature . . . . . -40°F to 150°F (-40°C to 66°C)  
Bake out . . . . . 250°F (121°C) in the open position

### functional performance

Flow capacity:

AOP . . . . .  $C_v = .17$   
1/4 Turn manual . . . . .  $C_v = .15$   
(SEMI Flow Coefficient Test# F-32-0998)

Design Leak Rate:

Outboard . . . . .  $4 \times 10^9$  scc/sec He  
Inboard . . . . .  $2 \times 10^{10}$  scc/sec He  
Across seat . . . . .  $1 \times 10^9$  scc/sec He

Design Proof Pressure:

AOP . . . . . 188 psig (13 barg)  
1/4 Turn Manual . . . . . 375 psig (26 barg)

Design Burst Pressure:

AOP . . . . . 375 psig (26 barg)  
1/4 Turn Manual . . . . . 750 psig (52 barg)

### standard connections

SEMI Modular Interface

### surface finishes

Standard Ra . . . . . 5 micro inch  
(.13 micro meter) or less

### approximate weight

.7 lbs. (.32 kg)



# SM917 1-1/8"

## Dimensional Drawings

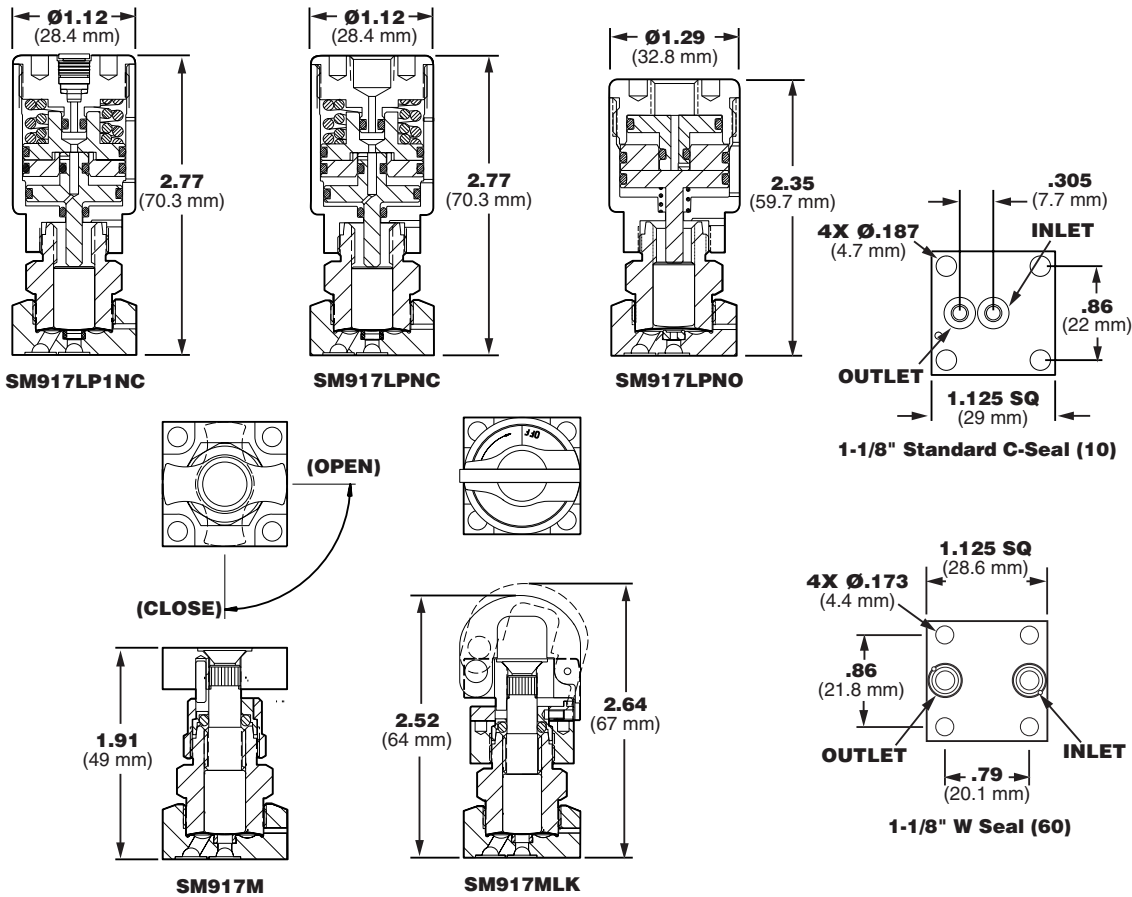

\* Standard Mini-Lever Is Blue

## Ordering Information

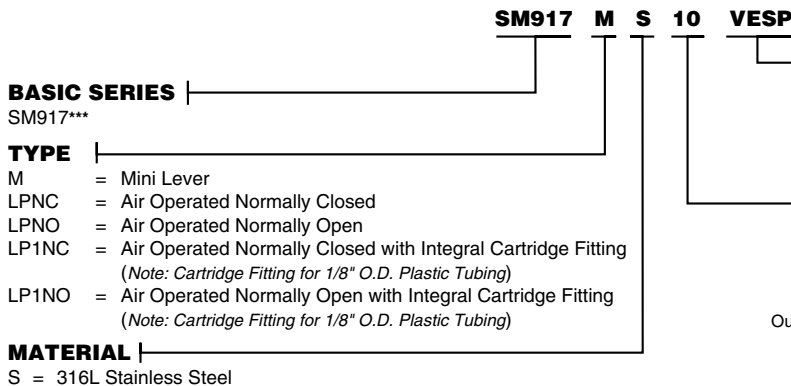

\* LK Includes LOTO Lever for Mini Lever type Valve.

\*\* Recommended for Nitrous Oxide (N<sub>2</sub>O) Service.

\*\*\* Only available with 1-1/8" body size

Vespe<sup>®</sup> is a registered trademark of DuPont Company.  
Elgiloy<sup>®</sup> is a registered trademark of Elgiloy Company.  
PEEK<sup>™</sup> is a trademark of Victrex plc.

### OPTIONAL FEATURES

LK = LockOut-TagOut\*  
VESP = Vespe<sup>®</sup> Seat\*\*  
PEEK = PEEK<sup>™</sup> Seat  
(Note: Consult Factory For Additional Handle Colors)

### PORTING

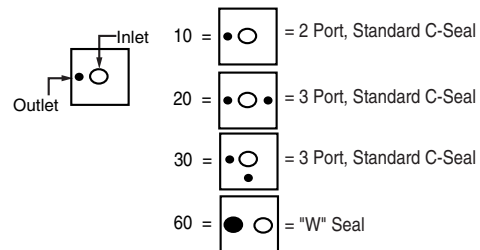

# SM930 1-1/8" & 1-1/2"

**UHP  
Diaphragm  
Valve**



Parker Hannifin Corporation's Veriflo Division presents the Surface Mount 930 Air Operated and Manual Diaphragm Valve. The SM930 diaphragm valve provides exceptional performance for today's modular surface mount systems.



## features

- ▶ Meets SEMI modular interface.
- ▶ "VeriClean", Veriflo's low sulfur high purity 316L Stainless Steel™, which enhances electropolishing, and corrosion resistance.
- ▶ Standard surface finish 5 micro inch Ra (.13 micro meter).
- ▶ Internally threadless and springless.
- ▶ Fully field serviceable seat (special tool required).
- ▶ Fully functional for pressure ranges from vacuum to 125 psig for Air Operated valves and 250 psig for manual valves.
- ▶ Change from air operated actuator to lever or visa versa without intruding into wetted area.
- ▶ 100% Helium leak tested.

## materials of construction

### Wetted

Body . . . . . "VeriClean", Veriflo's custom high purity type 316L Stainless Steel™  
 Seat . . . . . PCTFE, optional Vespel® or PEEK™  
 Diaphragm . . . . . Elgiloy® or equivalent

### Non-wetted

Nut . . . . . Stainless Steel  
 Cap . . . . . Stainless Steel

## operating conditions

Maximum operating pressure:  
 AOP . . . . . 125 psig (8.6 barg)  
 Manual . . . . . 250 psig (17 barg)  
 Minimum operating pressure . . . . . Vacuum  
 AOP Actuation . . . . . 75 psig (5 barg) nominal  
 Temperature . . . . . -40°F to 150°F  
 (-40°C to 66°C)  
 Bake out . . . . . 250°F (121°C) in the open position

## functional performance

Flow capacity:  
 Standard Seal  
 AOP . . . . .  $C_v = .25$   
 1/4 Turn manual . . . . .  $C_v = .20$   
 (SEMI Flow Coefficient Test# F-32-0998)

Design Leak Rate:  
 Outboard . . . . .  $1 \times 10^9$  scc/sec He  
 Inboard . . . . .  $2 \times 10^{10}$  scc/sec He  
 Across seat . . . . .  $1 \times 10^9$  scc/sec He

Design Proof Pressure:  
 AOP . . . . . 188 psig (13 barg)  
 1/4 Turn Manual . . . . . 375 psig (26 barg)

Design Burst Pressure:  
 AOP . . . . . 375 psig (26 barg)  
 1/4 Turn Manual . . . . . 750 psig (52 barg)

## standard connections

SEMI Modular Interface

## surface finishes

Standard Ra . . . . . 5 micro inch  
 (.13 micro meter) or less



# SM930 1-1/8" & 1-1/2"

## Dimensional Drawings 1-1/2"

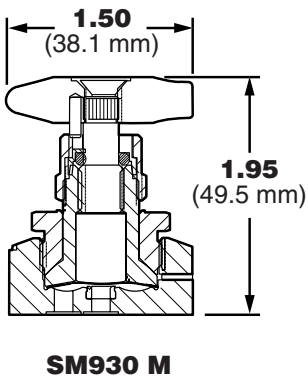
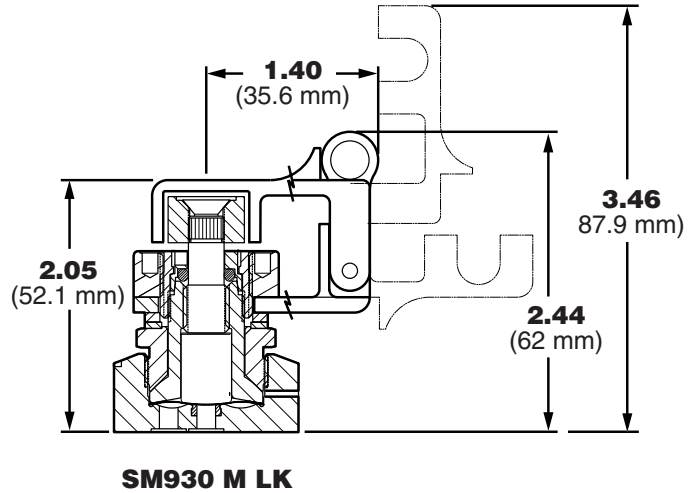
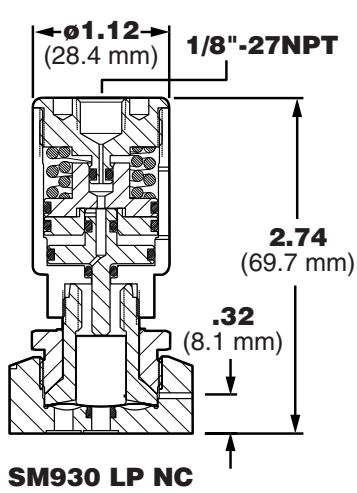

Standard Mini-Lever Color Is Blue

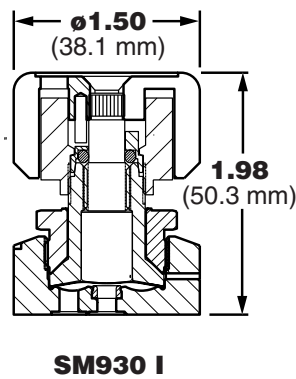

Standard Indicating Knob Color Is Black

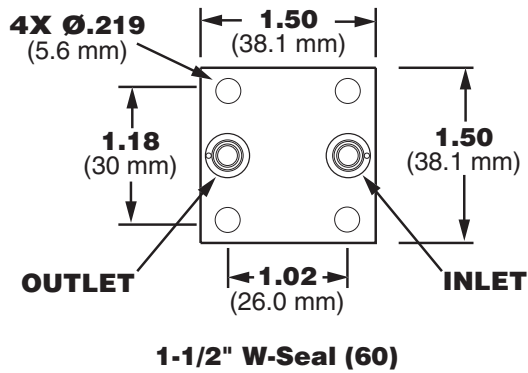
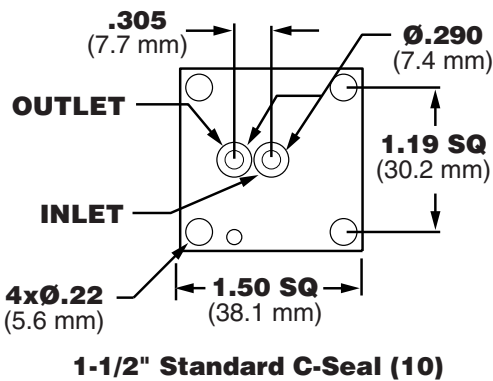

# SM930 1-1/8" & 1-1/2"

## Dimensional Drawings 1-1/8"

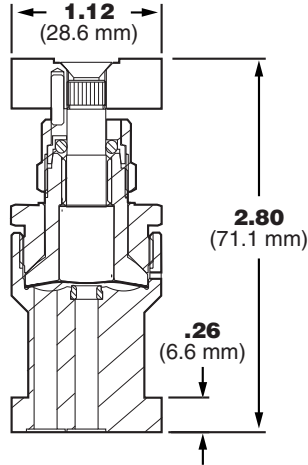

**SM930M\_2**

Standard Mini-Lever Color Is Blue

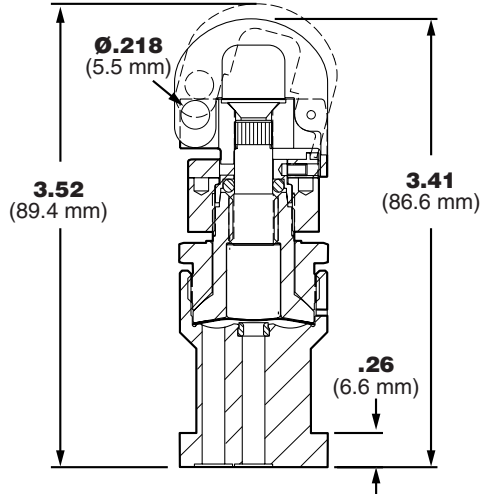

**SM930M\_2LK**

Standard Loto-Mini-Lever Color Is Red

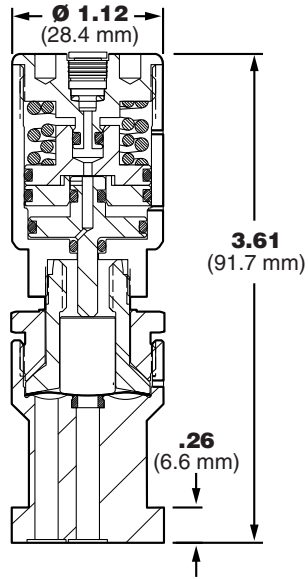

**SM930LP1NC\_2**

New Integral Cartridge Fitting Connects To 1/8" O.D. Plastic Tubing

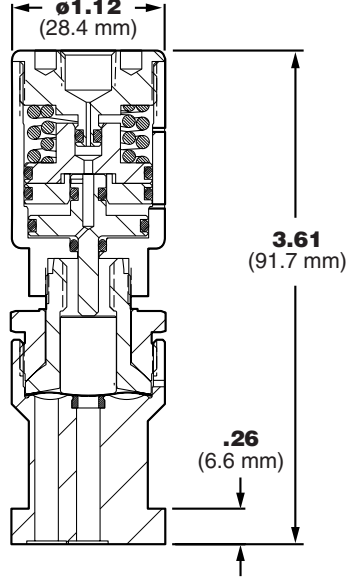

**SM930LPNC\_2**

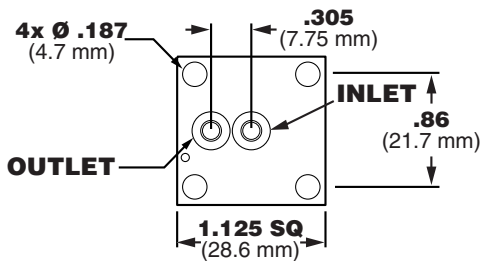

**1-1/8" Standard C-Seal (10)**

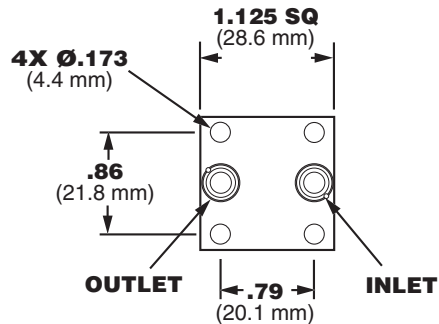

**1-1/8" W-Seal (60)**



# SM930 1-1/8" & 1-1/2"

## Ordering Information

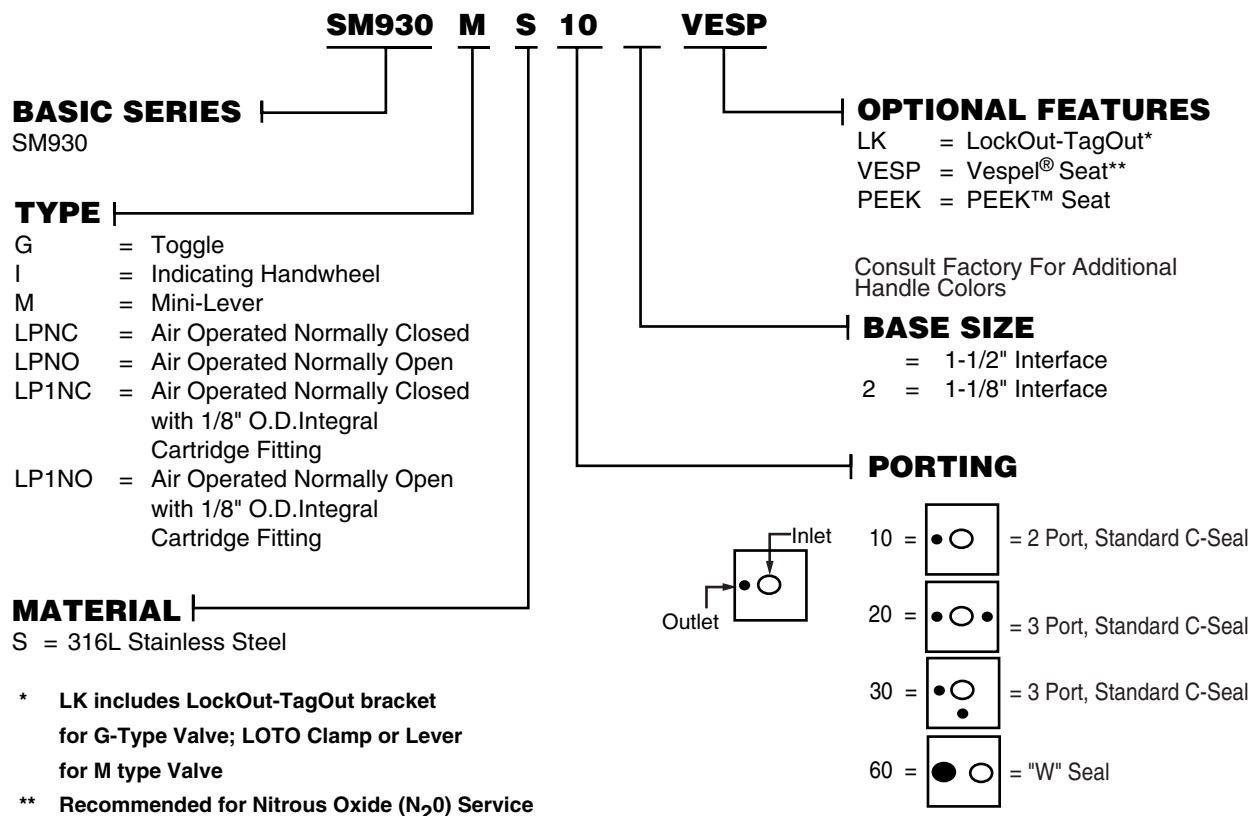

Elgiloy® is a registered trademark of Elgiloy Company.  
 Vespel® is a registered trademark of DuPont.  
 PEEK™ is a trademark of Victrex plc.

# SM955 Valve 1-1/2"

High Flow  
Diaphragm Valve



Parker Hannifin Corporation's Veriflo Division presents the Surface Mount 955 Air Operated and Manual Diaphragm Valve. The SM955 provides exceptional performance for today's modular surface mount systems that have high flow requirements.



## features

- ▶ Meets SEMI Modular Interface.
- ▶ Standard Seal: 0.30  $C_V$  for AOP style, 0.25  $C_V$  for 1/4 turn manual style. High Flow Seal: 0.50  $C_V$  for AOP style, 0.35  $C_V$  for 1/4 turn style valves.
- ▶ "VeriClean" low sulfur high purity 316L VAR Stainless Steel™, which enhances electropolishing, and corrosion resistance.
- ▶ Standard surface finish 5 micro inch Ra (.13 micro meter).
- ▶ Internally threadless and springless.
- ▶ Fully field serviceable seat (special tool required).
- ▶ Fully functional for pressure ranges from vacuum to 125 psig for Air Operated valves and 250 psig for manual valves.
- ▶ Change from air operated actuator to lever or visa versa without intruding into wetted area.
- ▶ 100% Helium leak tested.

## materials of construction

### Wetted

Body . . . . . "VeriClean", Veriflo's custom high purity Type 316L VAR Stainless Steel™  
Seat . . . . . PCTFE, optional Vespel®, or PEEK™  
Diaphragm . . . . . Elgiloy® or equivalent

### Non-Wetted

Nut . . . . . 316L Stainless Steel  
Cap . . . . . 316L Stainless Steel

## operating conditions

Maximum operating pressure:

AOP . . . . . 125 psig (8.6 barg)  
Manual . . . . . 250 psig (17 barg)

Minimum operating pressure . . . . . Vacuum

AOP Actuation . . . . . 75 psig (5 barg) nominal  
Temperature . . . . . -40°F to 150°F (-40°C to 66°C)  
Bake out . . . . . 250°F (121°C) in the open position

## functional performance

Flow capacity:

Standard Seal

AOP . . . . .  $C_V = .30$   
1/4 Turn Manual . . . . .  $C_V = .25$

High Flow Seal

AOP . . . . .  $C_V = .50$   
1/4 Turn Manual . . . . .  $C_V = .35$   
(SEMI Flow Coefficient Test# F-32-0998)

Design Leak Rate:

Outboard . . . . .  $1 \times 10^{-9}$  scc/sec He  
Inboard . . . . .  $2 \times 10^{-10}$  scc/sec He  
Across seat . . . . .  $4 \times 10^{-9}$  scc/sec He

Design Proof Pressure:

AOP . . . . . 188 psig (13 barg)  
1/4 Turn Manual . . . . . 375 psig (26 barg)

Design Burst Pressure:

AOP . . . . . 375 psig (26 barg)  
1/4 Turn Manual . . . . . 750 psig (52 barg)

## standard connections

SEMI modular interface

## internal volume

.70 cc

## surface finishes

Standard Ra . . . . . 5 micro inch  
(.13 micro meter) or less

## approximate weight

.70 lbs (.32 kg)



# SM955 Valve 1-1/2"

## Dimensional Drawings

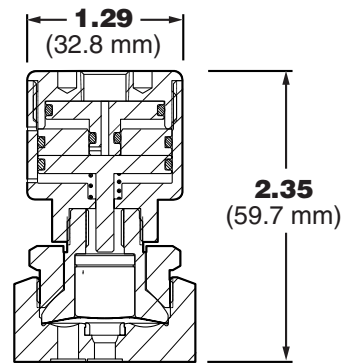
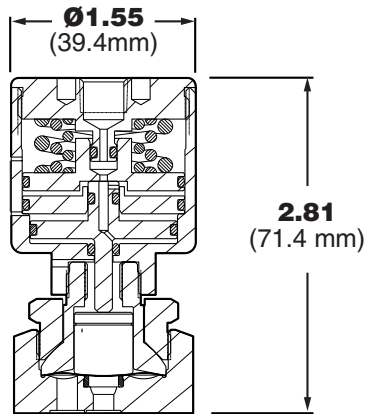
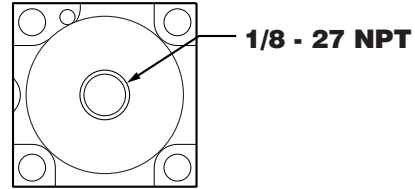
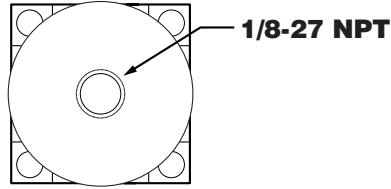

**SM955 LP NC**

**SM955 LP NO**

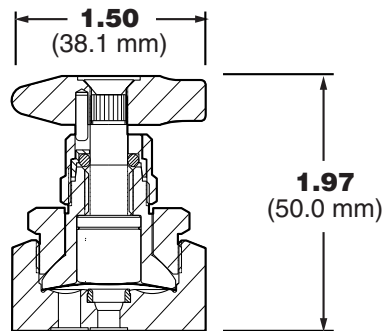
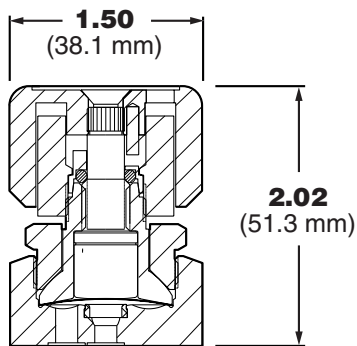
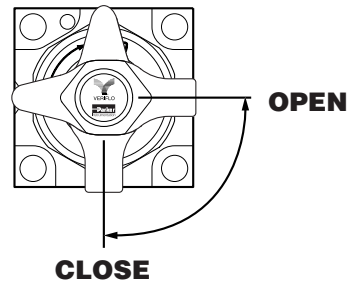
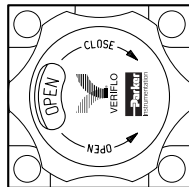

**SM955 I**

**SM955 M**

# SM955 Valve 1-1/2"

## Dimensional Drawings

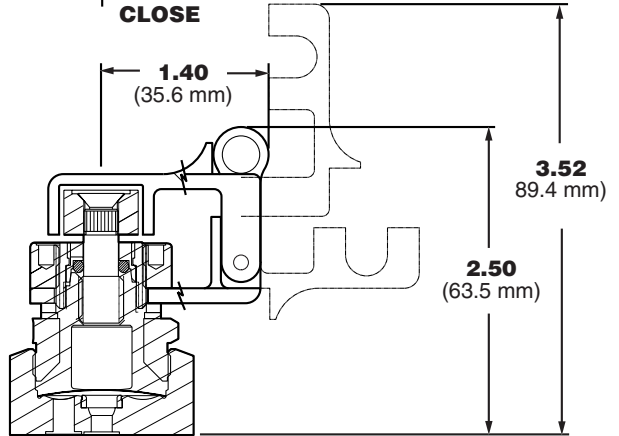
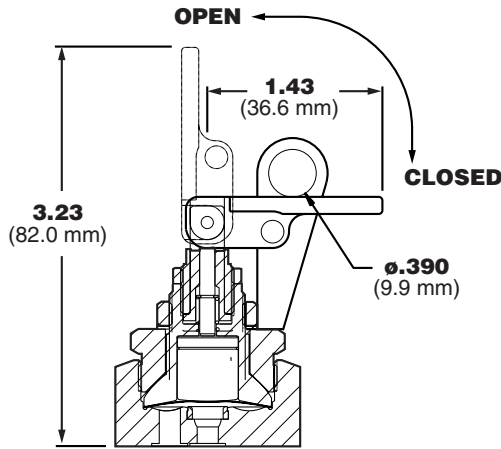
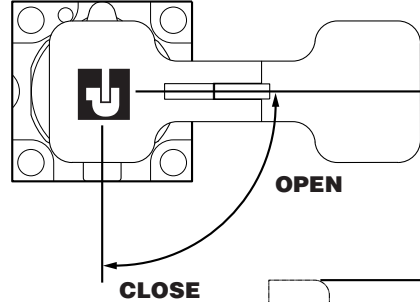
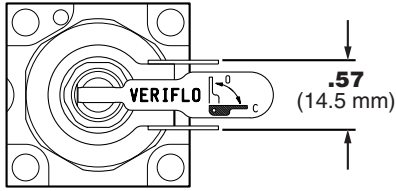

SM955 G LK

SM955 M LK

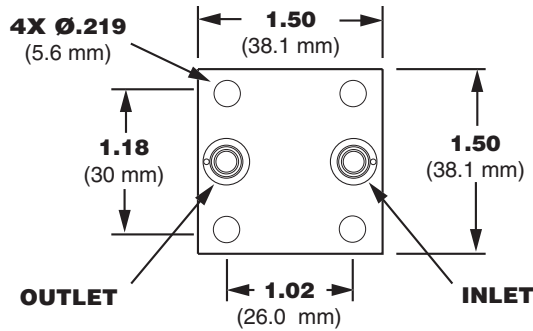
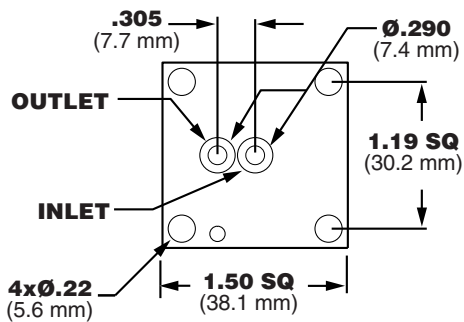

1-1/2" Standard C-Seal (10)

1-1/2" W Seal (60)

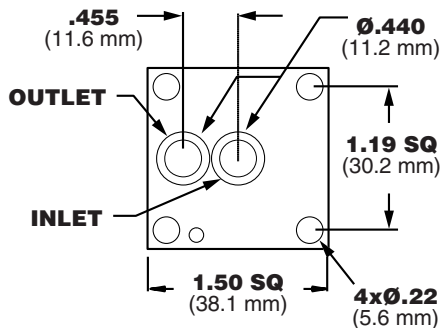

1-1/2" High Flow C-Seal (11)

# SM955 Valve 1-1/2"

## Ordering Information

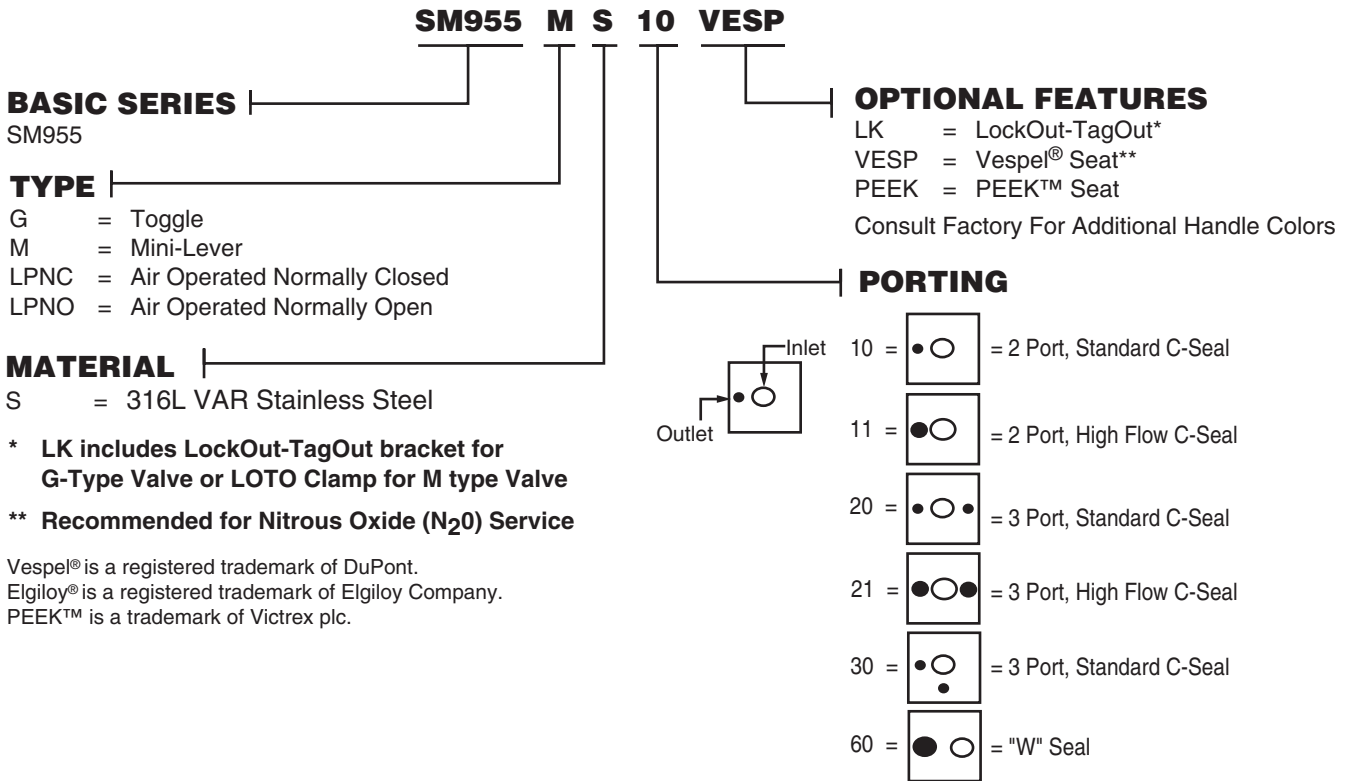

# QUANTUM 930 Valve



Parker Hannifin Corporation's Veriflo Division presents the 930 valve for use in ultra high purity applications.



## features

- ▶ "VeriClean", Veriflo's low sulfur high purity 316L VAR Stainless Steel™, which enhances electropolishing, welding and corrosion resistance.
- ▶ Standard surface finish 5 micro inch Ra (.13 micro meter).
- ▶ Internally threadless and springless.
- ▶ Fully functional from vacuum to 125 psig (for Air Operated Actuator), 250 psig for manual versions.
- ▶ Aerodynamic, fully swept flow passages.
- ▶ Minimum particle generation and particle entrapment areas.
- ▶ Change from air operated actuator to lever or visa versa without intruding into wetted area.
- ▶ 100% Helium leak tested.
- ▶ Maintains key dimensions of Veriflo's 944 and 945 valves.



## materials of construction

### Wetted

Body . . . "VeriClean", Veriflo's custom high purity type 316L VAR Stainless Steel™, Hastelloy C-22®  
 Seat . . . . . PCTFE, optional Vespel®  
 Diaphragm . . . . . Elgiloy® or equivalent

### Non-wetted

Nut . . . . . 316L Stainless Steel  
 Cap . . . . . 316L Stainless Steel

## operating conditions

Maximum operating pressure:  
 AOP . . . . . 125 psig (8.6 barg)  
 Manual . . . . . 250 psig (17 barg)  
 Minimum operating pressure . . . . . Vacuum  
 AOP Actuation . . . . . 75 psig (5 barg) nominal  
 Temperature . . . . . 0°F to 150°F (-18°C to 66°C)  
 Bake out . . . . . 250°F (121°C) in the open position

## functional performance

Flow capacity:  
 AOP . . . . .  $C_V = .3$   
 Lever . . . . .  $C_V = .22$

Design Leak Rate:  
 Outboard . . . . . less than  $1 \times 10^{-9}$  scc/sec He  
 Inboard . . . . . less than  $2 \times 10^{-10}$  scc/sec He  
 Across seat . . . . . less than  $1 \times 10^{-9}$  scc/sec He

Design Proof Pressure:  
 AOP . . . . . 188 psig (13 barg)  
 Manual . . . . . 375 psig (26 barg)

Design Burst Pressure:  
 AOP . . . . . 375 psig (26 barg)  
 Manual . . . . . 750 psig (52 barg)

## standard configuration

Any configuration of FS male and/or female fittings.  
 1/4" gland to gland length . . . . .  $2.78 \pm .02$  in.  
 (70.6 ± .05 mm)  
 Optional . . . . .  $3.06 \pm .02$  in. ( $77.7 \pm .05$  mm)  
 1/2" gland to gland length . . . . .  $4.14 \pm .02$  in.  
 (105.2 mm)  
 1/4" tube stubs inlet and outlet  
 End to end length . . .  $1.75 \pm .02$  in. ( $44.5 \pm .05$  mm)  
 Optional . . . . .  $1.61 \pm .02$  in. ( $40.7 \pm .05$  mm)  
 3/8" & 1/2" tube stubs inlet and outlet

End to end length . . .  $2.24 \pm .02$  in. ( $56.9 \pm .05$  mm)  
 Other configurations available including as many as five ports.

See Valve Selection Guide.

## internal volume

2.64 cc (including face seal fittings)

## surface finish

Standard Ra . . . . . 5 micro inch  
 (.13 micro meter) or less

## approximate weight

1.75 lbs. (.80 kg)

# QUANTUM 930 Valve

## Dimensional Drawings

**930 AOP LP NC**

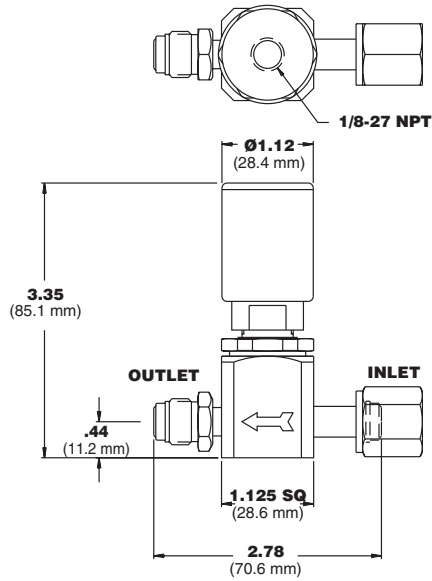

**930 AOP LP NO**

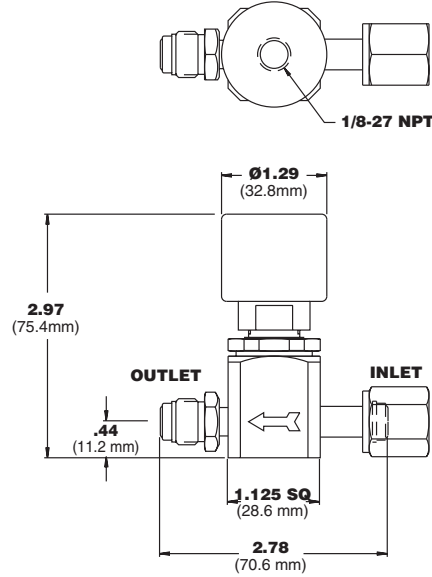

**930 L FS8**

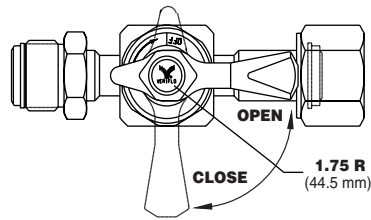

**930 L TS8**

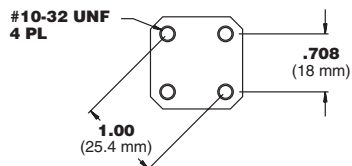
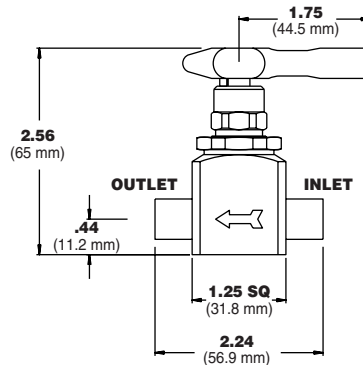
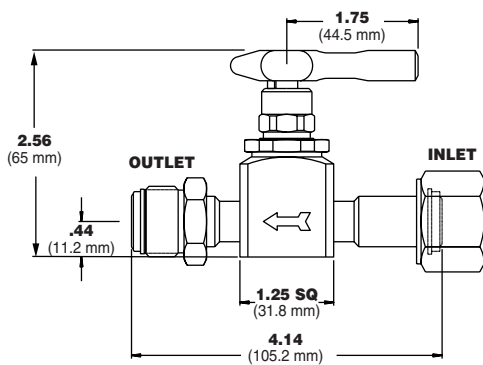
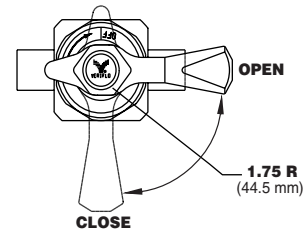

**Standard Mounting Hole Pattern**

# QUANTUM 930 Valve

## Dimensional Drawings

**930 M**

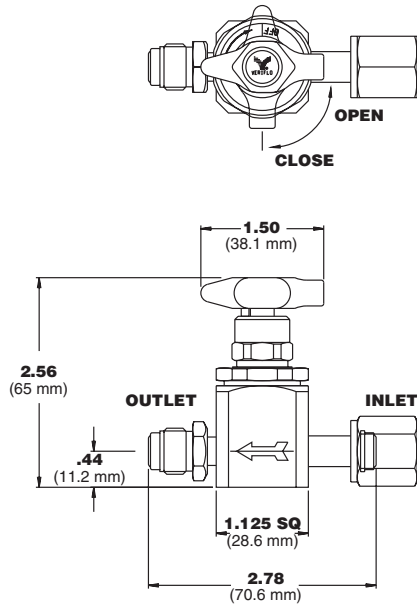

**930 I**

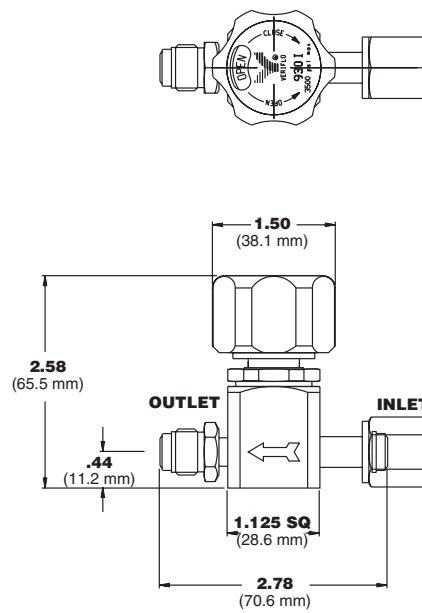

**930 G LK BRACKET**

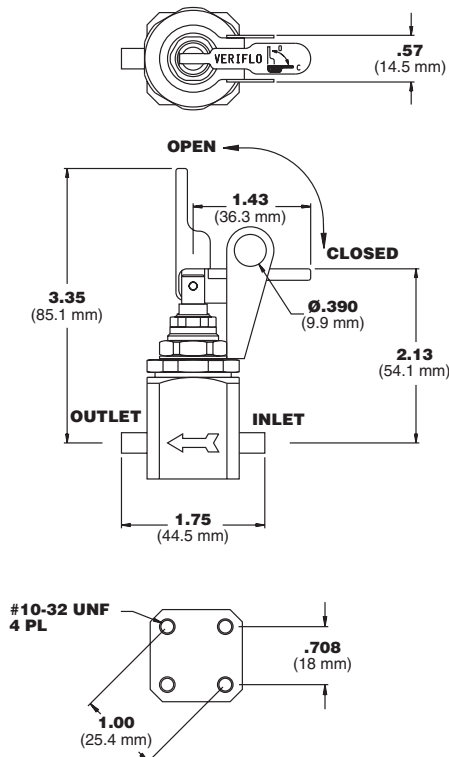

**930 M LK CLAMP**

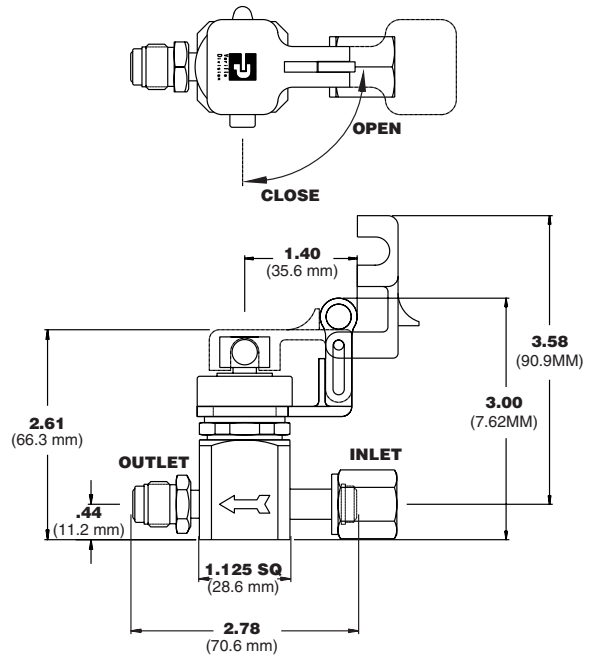

**Standard Mounting Hole Pattern**



# QUANTUM 930 Valve

## Flow Curve

### .3 C<sub>v</sub> Actuator Types

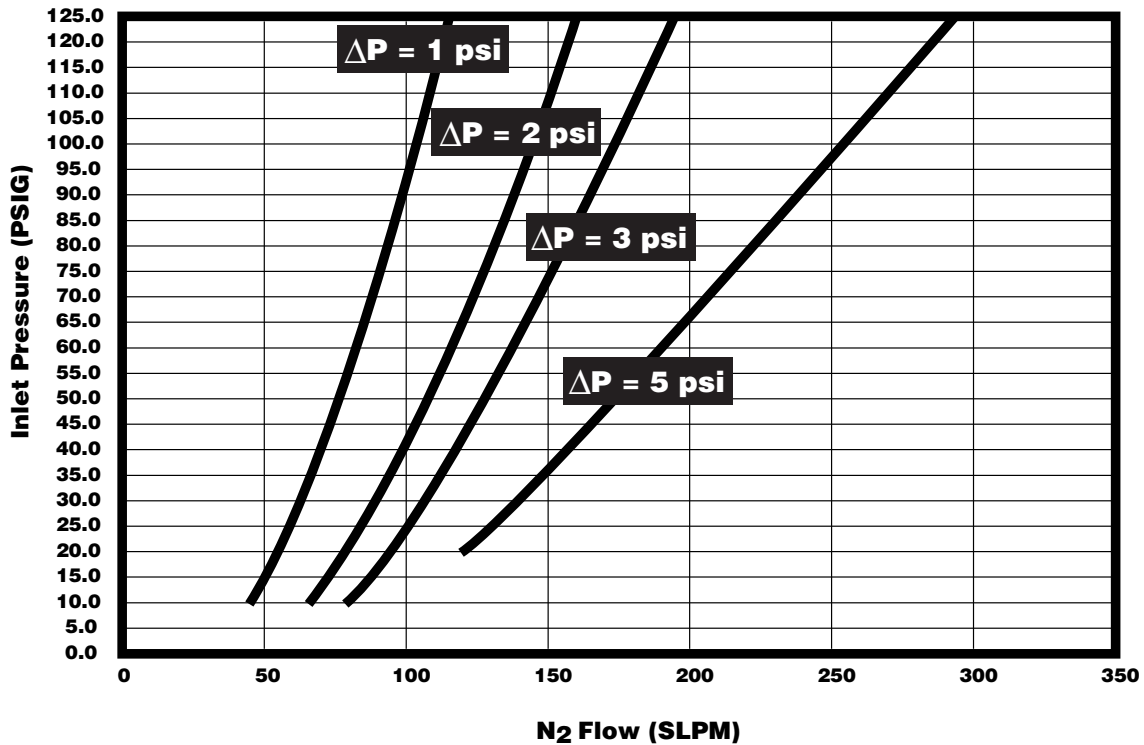

## Ordering Information

### 930 AOPLPNC S FSFM VESP

#### BASIC SERIES

930

#### TYPE

- AOPLPNC = Air Operated, Low Pressure, Normally Closed
- AOPLPNO = Air Operated, Low Pressure, Normally Open
- G = Toggle
- I = Indicating Handwheel
- L = Lever
- M = Mini Lever
- S = Spin Handwheel

#### MATERIAL

- S = 316L VAR Stainless Steel
- H = Hastelloy C-22®

\* 1/2" Connections use larger size body, please see dimensional drawings

\*\* LockOut-TagOut Clamp for M Type Valves  
LockOut-TagOut Bracket for G Type Valves

\*\*\* Not available on I and AOP versions

Hastelloy C-22® is a registered trademark of Haynes International, Inc.

Kel-F 81® is a registered trademark of 3M Company.

Vespe® is a registered trademark of DuPont Company.

Elgiloy® is a registered trademark of Elgiloy Company.

#### OPTIONAL FEATURES

- VESP = Vespe® Seat (For N<sub>2</sub>O use)
- LK = LockOut-TagOut \*\*
- PM = Panel Mount \*\*\*
- 2.3 = 1/4" Fixed Male Face Seal (2 Port Only)

#### CONNECTIONS

- FSMM = 1/4" Face Seal, Male in-Male out
- FSFF = 1/4" Face Seal, Female in-Female out
- FSFM = 1/4" Face Seal, Female in-Male out
- FSMF = 1/4" Face Seal, Male in-Female out
- FS8MM\* = 1/2" Face Seal, Male in-Male out
- FS8FF\* = 1/2" Face Seal, Female in-Female out
- FS8FM\* = 1/2" Face Seal, Female in-Male out
- FS8MF\* = 1/2" Face Seal, Male in-Female out
- TS = 1/4" Tube Stub
- TS6 = 3/8" Tube Stub
- TS8\* = 1/2" Tube Stub

# QUANTUM 930Y

## High Purity Manifold Valve



Parker Hannifin Corporation's Veriflo Division presents the 930Y, a diaphragm valve engineered to meet the specific requirements of semiconductor OEM tool manufacturers.

The 930Y is a sophisticated design with Veriflo's proven ultra high purity, low internal volume components. Space savings and fewer welds make the 930Y ideal for process control and purge systems.

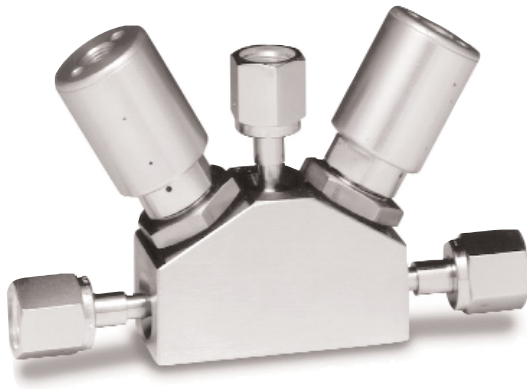

### features

- ▶ High cycle life.
- ▶ Ideal for valve manifold boxes (VMB).
- ▶ Ultra high performance.
- ▶ Internally threadless and springless.
- ▶ NO (normally open), NC (normally closed), or manual actuators available.
- ▶ Fully functional under vacuum conditions.

### materials of construction

#### Wetted

Body . . . . . "VeriClean", Veriflo's custom high purity Type 316L Stainless Steel™  
Seat . . . . . PCTFE (optional VespeI®, PEEK™)  
Diaphragm . . . . . Elgiloy® or equivalent

#### Non-wetted

Nut . . . . . 316L Stainless Steel  
Cap . . . . . 316L Stainless Steel

#### Actuator material

Body . . . . . Anodized Aluminum  
Pistons . . . . . Brass  
O-ring seals . . . . . Viton®

### operating conditions

Maximum operating pressure:

AOP . . . . . 125 psig (8.6 barg)  
Manual . . . . . 250 psig (17 barg)

Minimum operating pressure . . . . . Vacuum  
AOP Actuation . . . . . 75 psig (5 barg) nominal  
Temperature . . . . . 0°F to 150°F (-18°C to 66°C)  
Bake out . . . . . 250°F (121°C) in the open position

### functional performance

Flow capacity:

AOP . . . . .  $C_V = .3$   
Lever . . . . .  $C_V = .22$   
(SEMI Flow Coefficient Test #F-32-0998)

Design Leak Rate:

Outboard . . . . . less than  $1 \times 10^9$  scc/sec He  
Inboard . . . . . less than  $2 \times 10^{10}$  scc/sec He  
Across seat . . . . . less than  $1 \times 10^9$  scc/sec He

Design Proof Pressure:

AOP . . . . . 188 psig (13 barg)  
Manual . . . . . 375 psig (26 barg)

Design Burst Pressure:

AOP . . . . . 375 psig (26 barg)  
Manual . . . . . 750 psig (52 barg)

### surface finishes

Standard Ra . . . . . 10 micro inch  
(.25 micro meter) or less  
Optional Ra . . . . . EV = 5 micro inch  
(.13 micro meter) or less

### standard connections

Any combination of FS male and / or female fittings:

1/4" Gland to gland length . . . . . 4.69 or 4.06  
(see dimensional drawing)

1/4" tube stubs inlet and outlet available:

End to end length . . . . . 3.62

### internal volume

4.26 cc

### approximate weight

2.1 lbs (0.95 kgs)



# QUANTUM 930Y

## Dimensional Drawings

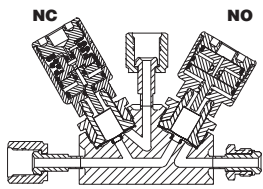

930Y1NO/NCFSMFFA

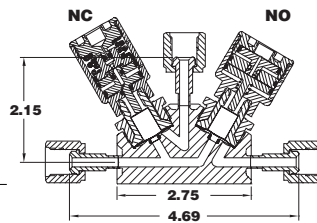
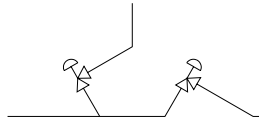

930Y1NO/NCFSFFA

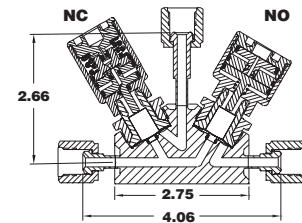

930Y1NO/NCFSFFB

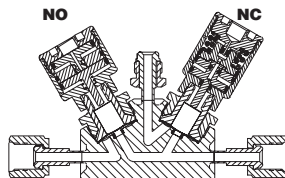

930Y2NC/NOFSMFA

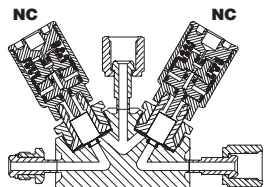
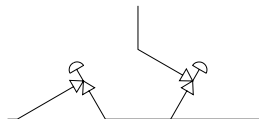

930Y3NC/NCFSFFMA

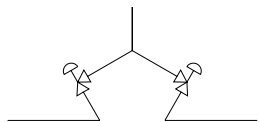

## Ordering Example

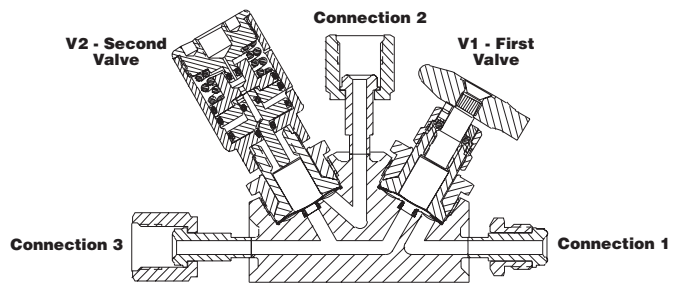

930Y1M/NCFSMFFA

## Ordering Information

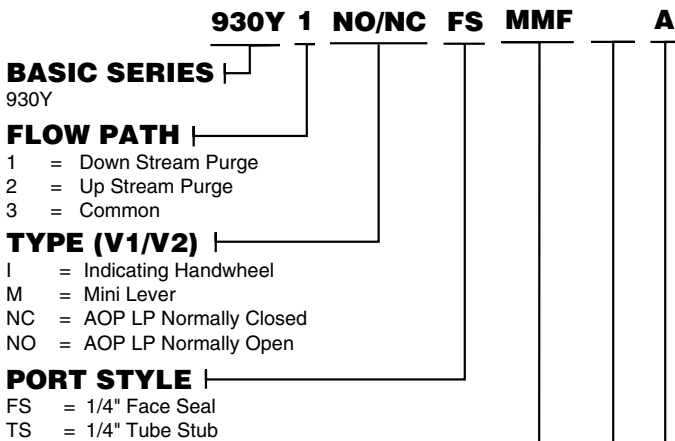

\* Recommended for Nitrous Oxide (N<sub>2</sub>O) Service.

Elgiloy® is a registered trademark of Elgiloy Company.  
Vespe® is a registered trademark of DuPont Company.  
PEEK™ is a registered trademark of Pictrex plc.

## Flow Curve

### .3 C<sub>v</sub> Actuator Types

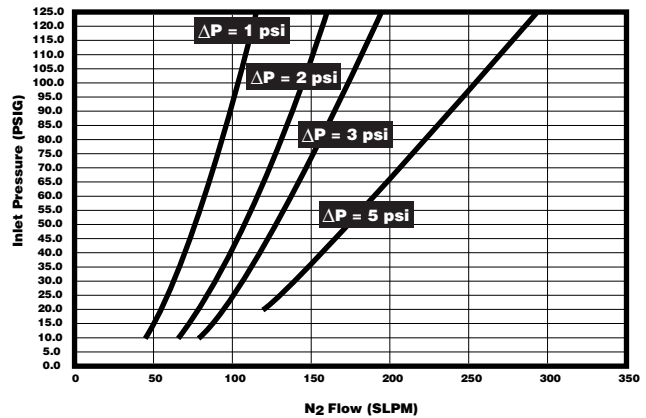

### DIMENSIONS

A = 4.69 x 2.15  
B = 4.06 x 2.66 (FSF or TS only)

### OPTIONAL FEATURES

RD = Red Lever  
BK = Black Lever  
PEEK = PEEK™ Seats  
VESP = Vespe® Seats\*

### PORT CONFIGURATION

M = Face Seal Male  
F = Face Seal Female  
Blank = Tube Stub



# QUANTUM 945 Valve



Parker Hannifin Corporation's Veriflo Division presents the Quantum 945 Valve. The 945 was designed specifically for semiconductor process control and have all of the features and benefits of the 944 Series with reduced internal volume and body size.

A unique feature of the 945 is the machined-on tube stubs, which allows for improved dimensional control.



## features

- ▶ "VeriClean", low sulfur high purity 316L Stainless Steel™ enhances electropolishing, welding and corrosion resistance.
- ▶ Standard Surface Finish is 5 micro inch Ra.
- ▶ Machined on tube stubs or fixed male Face Seal connections.
- ▶ Fully field serviceable seat can be replaced without special tools.
- ▶ Interchangeable actuators without breaking into wetted area.
- ▶ Internally threadless and springless.
- ▶ NO (normally open) or NC (normally closed) actuator available.
- ▶ Fully functional under vacuum conditions.
- ▶ Unique patented compression member which loads the seal uniformly without the need for threaded components or crimping operations.

## materials of construction

### Wetted

Body . . . "VeriClean", Veriflo's custom high purity type 316L Stainless Steel™, optional Hastelloy C-22®  
 Seat . . . . . PCTFE, optional Vespel®  
 Diaphragm . . . . . Elgiloy® or equivalent  
 Compression member . . . . "VeriClean", Veriflo's custom high purity type 316L Stainless Steel, optional Hastelloy C-22®

### Non-wetted

Nut . . . . . 316L Stainless Steel  
 Cap . . . . . 316L Stainless Steel

## operating conditions

Maximum operating pressure:  
 AOPHP and Manual . . . . . 3500 psig (240 barg)  
 AOPLP and Toggle . . . . . 125 psig (8.6 barg)  
 For oxygen . . . . . Refer to CGA G-4.4 Industrial Practices for Gaseous Oxygen

Minimum operating pressure . . . . . Vacuum

### Actuation pressure:

AOPLP . . . . . 60 to 120 psig (4 barg to 8.3 barg)  
 AOPHP . . . . . 75 psig nominal (5 barg)  
 Temperature . . . . . -40°F to 150°F (-40°C to 66°C)  
 Bakeout . . . . . 250°F (121°C) in the open position

## functional performance

### Flow capacity:

AOP,G,S,I . . . . .  $C_v = 0.25$   
 Lever . . . . .  $C_v = 0.18$   
 (SEMI Flow Coefficient Test #F-32-0998)

### Design Leak Rate:

Outboard . . . . .  $1 \times 10^9$  scc/sec He  
 Inboard . . . . .  $2 \times 10^{10}$  scc/sec He  
 Across Seat . . . . .  $4 \times 10^9$  scc/sec He

### Design Proof Pressure:

AOPHP and Manual . . . . . 5250 psig (362 barg)  
 AOPLP and Toggle . . . . . 188 psig (13 barg)

### Design Burst Pressure:

AOPHP and Manual . . . . . 10500 psig (724 barg)  
 AOPLP and Toggle . . . . . 375 psig (26 barg)

## standard connections

Any combination of FS male and / or female fittings or tube stubs including as many as five ports.

See Valve Selection Guide

## internal volume

1.26 cc (no glands); 2.7 cc (including glands)

## surface finishes

5 micro inch Ra (.13 micro meter) or less

## approximate weight

0.9 lbs (0.42 kgm)



# QUANTUM 945 Valve

## Dimensional Drawing

**945M**

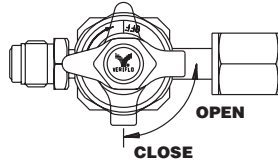

**945I**

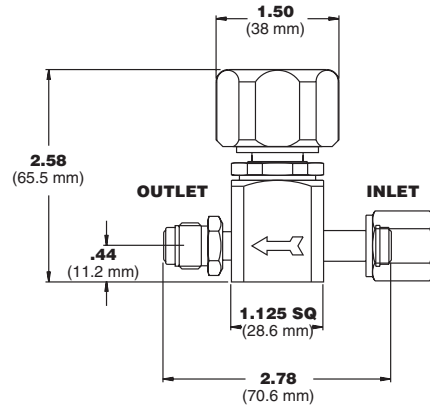
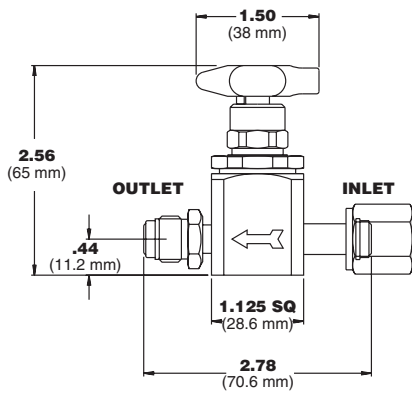
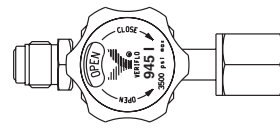

**945GLK BRACKET**

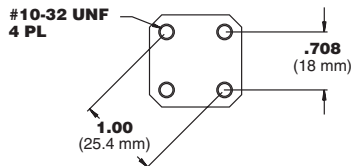
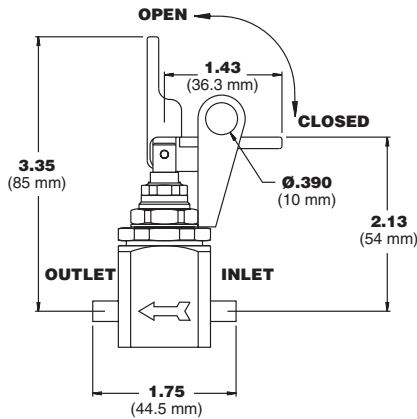
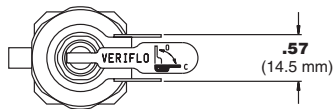

**Standard Mounting Hole Pattern**

**945MLK CLAMP**

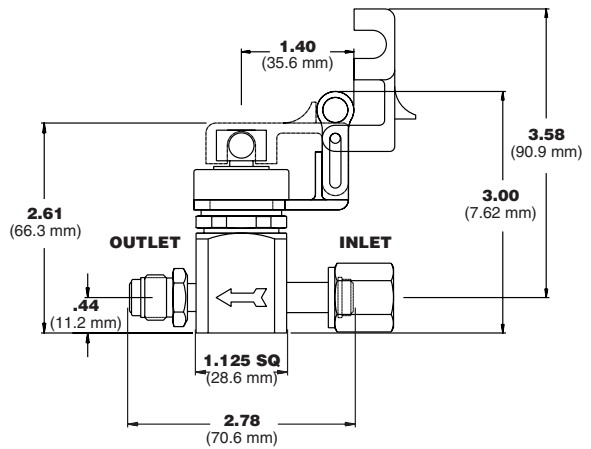
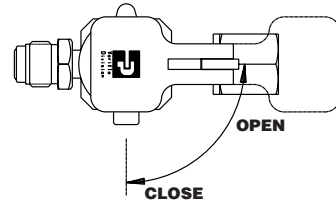

# QUANTUM 945 Valve

## Dimensional Drawing

**945AOPLPNC**

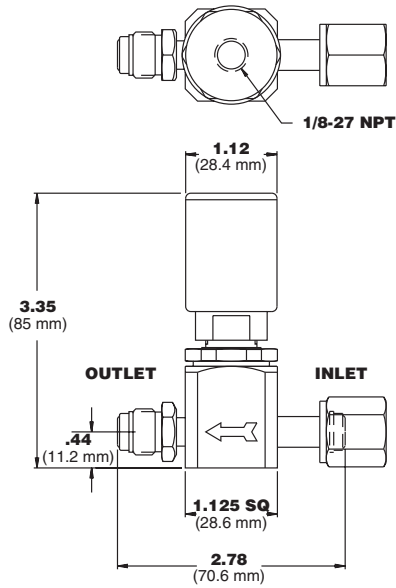

**945AOPLPNO**

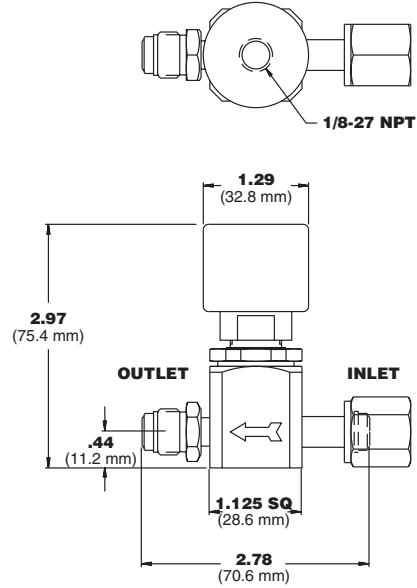

**945LSFS8FM**

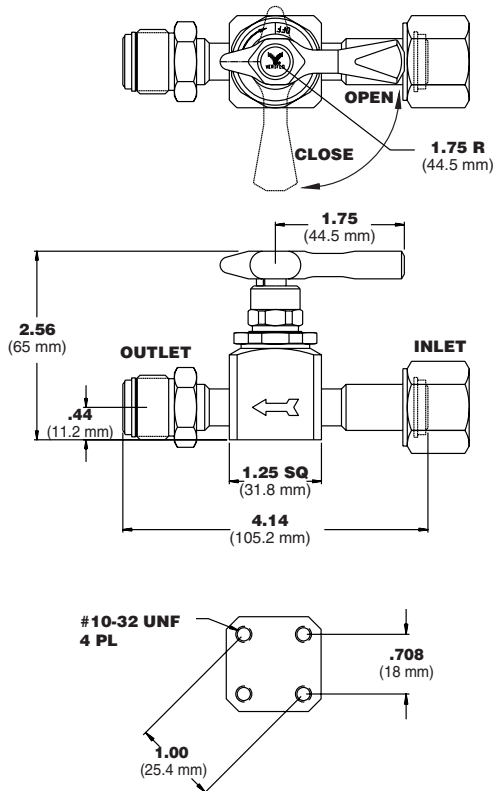

**945AOPHPNCST6**

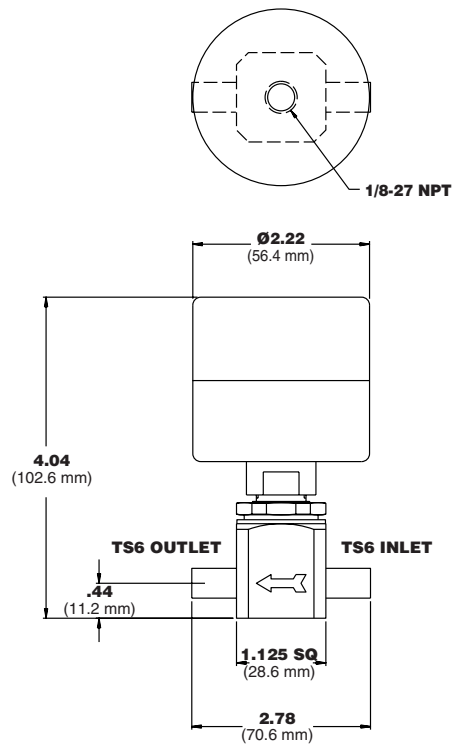

**Standard Mounting Hole Pattern**

# QUANTUM 945 Valve

## Flow Curve

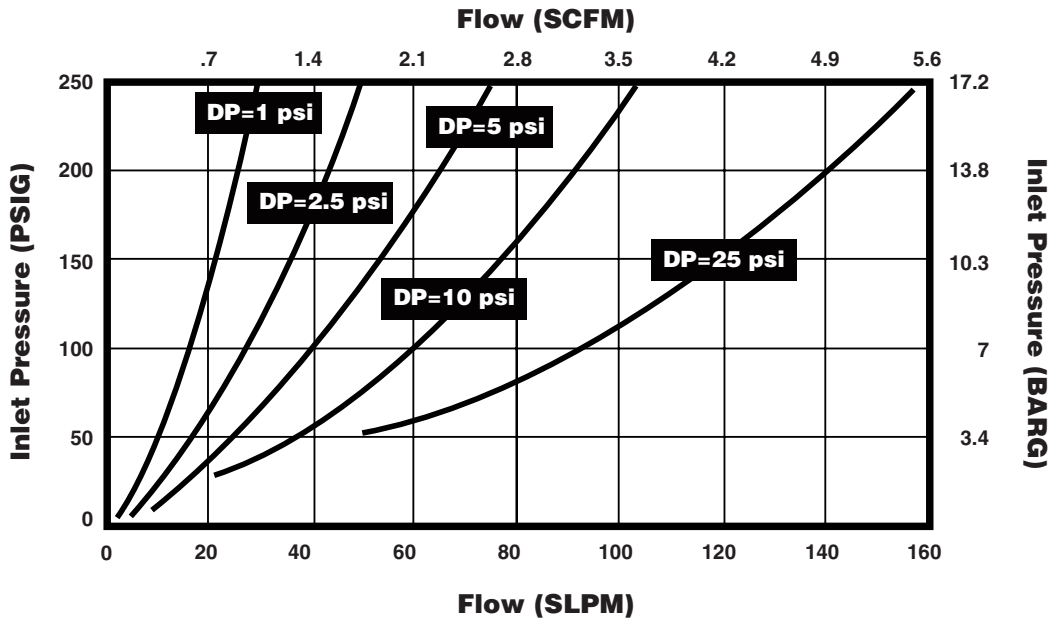

## Ordering Information

**945 L S FSMM VESP**

### BASIC SERIES

945

### TYPE

- AOPHPNC = Air Operated, High Pressure, Normally Closed
- AOPLPNC = Air Operated, Low Pressure, Normally Closed
- AOPLPNO = Air Operated, Low Pressure, Normally Open
- G = Toggle
- I = Indicating Handwheel
- L = Lever
- M = Mini Lever
- S = Handwheel

### MATERIAL

- S = 316L Stainless Steel
- H = Hastelloy C-22<sup>®</sup>\*

\* Includes Hastelloy C-22<sup>®</sup> body and compression member

\*\* LockOut-TagOut Clamp for M Type Valves

LockOut-TagOut Bracket for G Type Valves

\*\*\* Not available with Indicating Handwheel (I) or AOP Type Valves

\*\*\*\* Recommended for Nitrous Oxide (N<sub>2</sub>O) Service

◆ 1/2" Connections Use Larger Body Size, Please See Dimensional Drawings

### OPTIONAL FEATURES

- LK = LockOut-TagOut\*\*
- PM = Panel Mount\*\*\*
- TH = Hastelloy C-22<sup>®</sup> Trim (Compression Member)
- VESP = Vespel<sup>®</sup> Seat\*\*\*\*
- BK = Black Lever or Handwheel
- BU = Blue Indicating Handwheel
- 2.3 = 1/4" Fixed Male Face Seals (2 ported only)

### CONNECTIONS

- FSMM = 1/4" Face Seal, Male in-Male out
- FSFF = 1/4" Face Seal, Female in-Female out
- FSFM = 1/4" Face Seal, Female in- Male out
- FSMF = 1/4" Face Seal, Male in-Female out
- FS8MM = 1/2" Face Seal, Male in-Male out
- FS8FF = 1/2" Face Seal, Female in-Female out
- FS8FM = 1/2" Face Seal, Female in- Male out
- FS8MF = 1/2" Face Seal, Male in-Female out
- TS = 1/4" Tube Stubs
- TS6 = 3/8" Tube Stubs
- TS8 ◆ = 1/2" Tube Stubs

**Note: See Valve Selection Guide for multiple porting selections.**

Vespel<sup>®</sup> is a registered trademark of DuPont Company.

PEEK<sup>™</sup> is a registered trademark of Victrex plc.

Elgiloy<sup>®</sup> is a registered trademark of Elgiloy Company.

Hastelloy C-22<sup>®</sup> is a registered trademark of Haynes International, Inc.





Parker Hannifin Corporation's Veriflo Division presents the 945Y. The 945Y is a custom built high-purity diaphragm valve manifold, engineered to meet the specific requirements of semiconductor OEM tool manufacturers.

The 945Y is a sophisticated design with Veriflo's proven ultra high purity, low internal volume components. Space savings and fewer welds make the 945Y ideal for process control and purge systems.

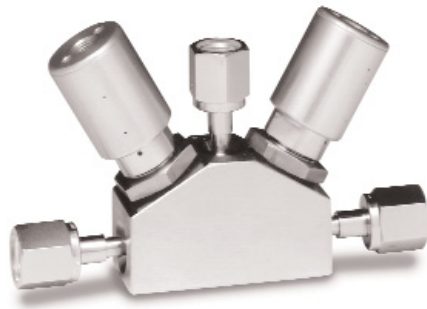

### features

- ▶ High cycle life.
- ▶ Ideal for valve manifold boxes (VMB).
- ▶ Fully field serviceable seat can be replaced without special tools.
- ▶ Ultra high performance.
- ▶ Internally threadless and springless.
- ▶ NO (normally open), NC (normally closed), or manual actuators available.
- ▶ Fully functional under all vacuum conditions.
- ▶ Unique patented compression member which loads the seal uniformly without the need for threaded component or crimping operations.

### materials of construction

#### Wetted

Body . . . . . "VeriClean", Veriflo's custom high purity Type 316L VAR Stainless Steel™  
 Seat . . . . . PCTFE, optional Vespel®, PEEK™  
 Diaphragm . . . . . Elgiloy® or equivalent  
 Compression member . . . "VeriClean", Veriflo's custom high purity type 316L VAR Stainless Steel optional Hastelloy C-22®

#### Non-wetted

Nut: . . . . . 316L stainless steel  
 Cap: . . . . . 316L stainless steel

#### Actuator material

Body . . . . . Anodized aluminum  
 Pistons . . . . . Brass  
 O-ring seals . . . . . Viton®

### operating conditions

Maximum operating pressure:  
 AOPHP and Manual . . . . . 3500 psig (240 barg)  
 AOPLP and Manual . . . . . 125 psig (8.6 barg)  
 For oxygen . . . . . Refer to CGA G-4.4 Industrial Practices for Gaseous Oxygen

Minimum operating pressure . . . . . Vacuum

#### Actuation pressure:

AOPLP . . . . . 60 to 120 psig (4 barg to 8.3 barg)  
 AOPHP . . . . . 75 psig nominal (5 barg)  
 Temperature . . . . . -40°F to 150°F (-40°C to 66°C)  
 Bakeout . . . . . 250°F (121°C) in the open position

### functional performance

Flow capacity  
 Process valve . . . . . C<sub>v</sub> 0.25  
 Purge Valve . . . . . C<sub>v</sub> 0.17  
 (SEMI Flow Coefficient Test #F-32-0998)

#### Design Leak Rate:

Across Seat . . . . . 4 x 10<sup>9</sup> scc/sec He  
 Inboard . . . . . 2 x 10<sup>10</sup> scc/sec He  
 Outboard . . . . . 1 x 10<sup>9</sup> scc/sec He

### surface finishes

Standard Ra . . . . . 10 micro inch (.25 micro meter) or less

Optional Ra . . . . . EV = 5 micro inch (.13 micro meter) or less

### standard connections

Any combination of FS male and / or female fittings:  
 1/4" Gland to gland length . . . . . 4.69 or 4.06 (see dimensional drawing)

#### 1/4" tube stubs inlet and outlet available:

End to end length: . . . . . 3.62

### internal volume

4.26 cc

### approximate weight

2.1 lbs (0.98 kgm)



# QUANTUM 945Y

## Dimensional Drawings

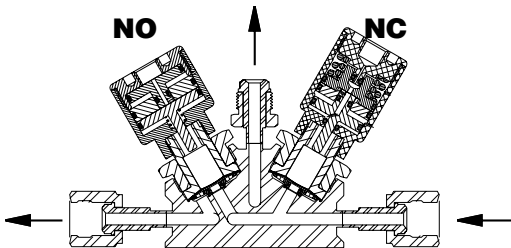
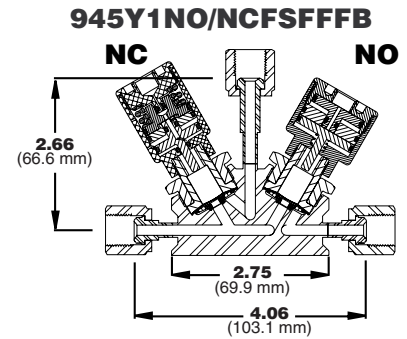
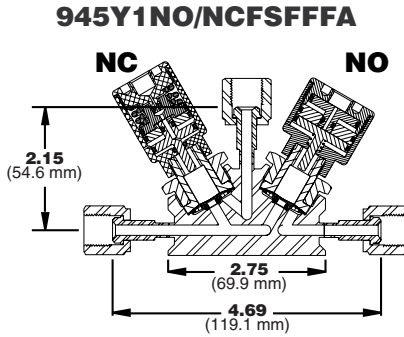
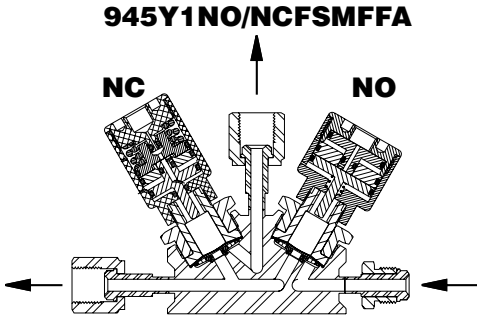

945Y2NC/NOFSMFA

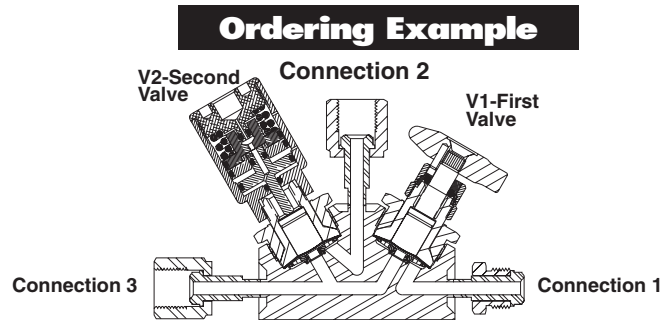

## Ordering Example

945Y1M/NCFSMFFA

## Ordering Information

945Y 1 NO/NC FS MFF TH A

### BASIC SERIES

945Y

### FLOW PATH

- 1 = Down Stream Purge
- 2 = Up Stream Purge
- 3 = Common

### TYPE (V1/V2)

- HP= AOPHP Normally Closed\*
- I = Indicating Handwheel
- M = Mini Lever
- NC= AOPLP Normally Closed
- NO = AO LP Normally Open

- \* Note: HP can only be used in combination with HP or M type actuators.
- \*\* Recommended for Nitrous Oxide (N<sub>2</sub>O) Service

Hastelloy C-22<sup>®</sup> is a registered trademark of Haynes International, Inc.  
 Vespe<sup>®</sup> is a registered trademark of DuPont Company.  
 Viton<sup>®</sup> is a registered trademark of DuPont Elastomers Company.  
 Elgiloy<sup>®</sup> is a registered trademark of Elgiloy Company.  
 PEEK<sup>™</sup> is a registered trademark of Victrex plc.

### DIMENSIONS

- A = 4.69 x 2.15
- B = 4.06 x 2.66 (FSF or TS Only)

### OPTIONAL FEATURES

- TH = Hastelloy C-22<sup>®</sup> Trim (Compression Member)
- PEEK = PEEK<sup>™</sup> Seats
- VESP = Vespe<sup>®</sup> Seats\*\*

### PORT CONFIGURATION

- M = Face Seal Male
- F = Face Seal Female

### PORT STYLE

- FS = 1/4" Face Seal Male
- TS = 1/4" Tube Stub

## Flow Curve

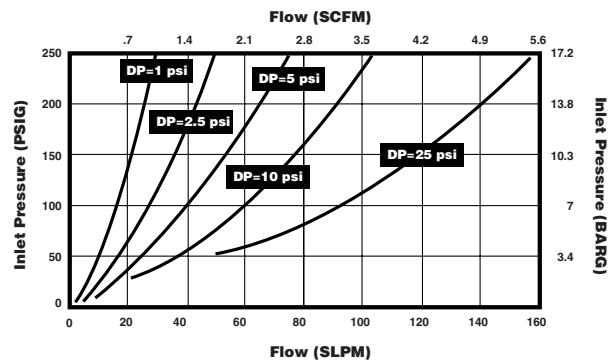



Parker Hannifin Corporation's Veriflo Division presents the Quantum 955 Manually Operated diaphragm valve. The 955 provides higher flows in an exceptionally clean, compact device.



### features

- ▶ .55  $C_v$  flow capacity.
- ▶ "VeriClean" low sulfur high purity 316L Stainless Steel™, which enhances electropolishing, welding, and corrosion resistance.
- ▶ Internally threadless and springless.
- ▶ Ideal for low vapor pressure gases.
- ▶ Fully functional from vacuum to 250 psig.
- ▶ Aerodynamic, smooth flow passages.
- ▶ Minimum particle generation and entrapment.
- ▶ High cycle life.
- ▶ 100% Helium leak tested.
- ▶ "Hurricane" cleaning, Veriflo's proprietary cleaning process, removes metallic ions, organic films and surface adhering particles.

### materials of construction

#### Wetted

Body . . . . . "VeriClean", Veriflo's custom high purity Type 316L Stainless Steel™, Hastelloy® C-22  
Seat . . . . . PCTFE, optional Vespel®, PEEK™  
Diaphragm . . . . . Elgiloy® or equivalent

#### Non-Wetted

Nut . . . . . 316L Stainless Steel  
Cap . . . . . 316L Stainless Steel

### operating conditions

Maximum operating pressure . . . . . 250 psig  
(17.22 barg)  
For oxygen . . . . . Refer to CGA G-4.4  
Industrial practices for gaseous oxygen

Minimum operating pressure . . . . . Vacuum  
Temperature . . . . . -40°F to 150°F (-40°C to 65°C)  
Bake out . . . . . 250°F (121°C) in the open position

### functional performance

Flow capacity . . . . .  $C_v = .55$   
(SEMI Flow Coefficient Test #F-32-0998)

#### Design Leak Rate:

Outboard . . . . .  $1 \times 10^{-9}$  scc/sec He  
Inboard . . . . .  $2 \times 10^{-10}$  scc/sec He  
Across seat . . . . .  $4 \times 10^{-9}$  scc/sec He

Design Proof Pressure . . . . . 375 psig (26 barg)  
Design Burst Pressure . . . . . 750 psig (52 barg)

### standard connections

Any combination of FS male and/or female fittings:

1/4" Gland to gland length . . . . . 2.96 in.  
(75.1 mm)  
Optional . . . . . 2.78 in. (70.6 mm)

#### Tube stubs inlet and outlet:

End to end length . . . . . 2.25 in. (57.1 mm)

Note : Other configurations available as options including as many as five ports

### internal volume

3.29 cc (including face seal fittings)

### surface finishes

Standard Ra . . . . . 5 micro inch  
(.13 micro meter) or less

### approximate weight

.81 lbs (.36 kg)

# QUANTUM 955

## Dimensional Drawing

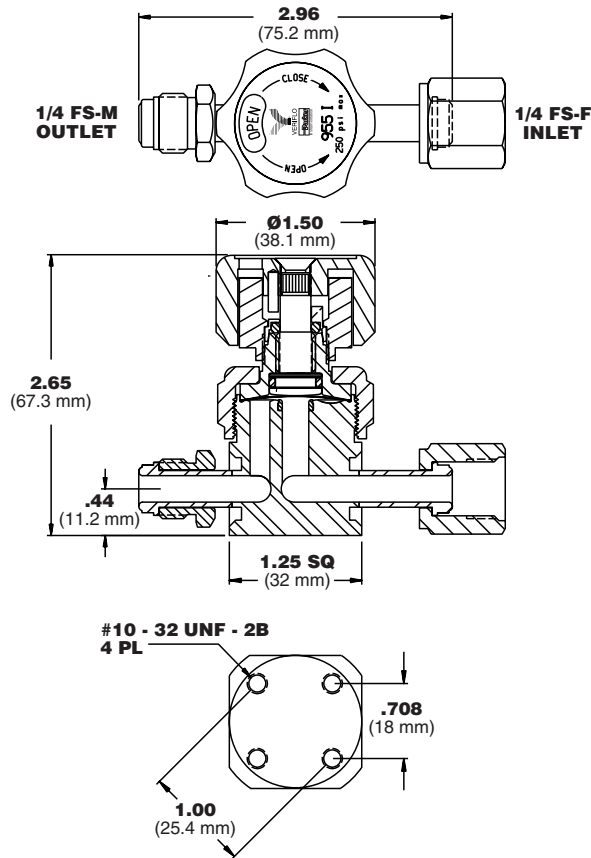

## Flow Curve

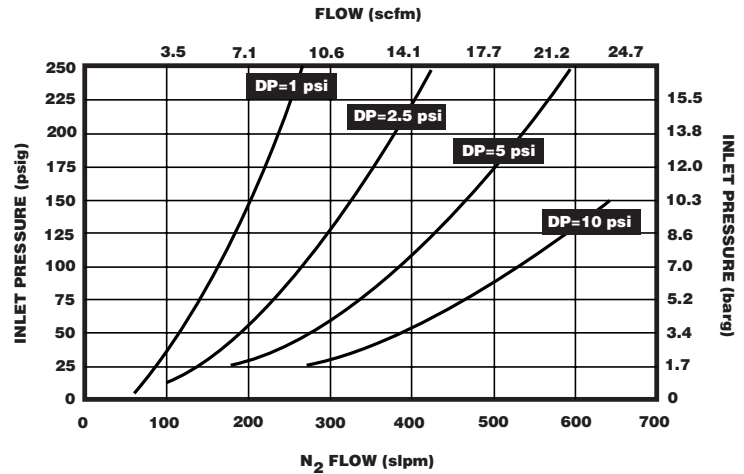

Nitrogen gas was used for flow curves.

1/4" FS	2.96" (75.1 mm) STD
1/2" FS8	4.20" (106.7 mm) STD
1/4" TS	2.25" (57.1 mm)
3/8" TS6	2.25" (57.1 mm) STD
1/2" TS8	2.25" (57.1mm) STD
1/4" FS	2.78" (70.6 mm) Optional

## Ordering Information

**955 L S FSMM VESP**

**BASIC SERIES**

955

**TYPE**

G = Toggle  
I = Indicating Handwheel  
L = Lever  
M = Mini Lever

**MATERIAL**

S = 316L VAR Stainless Steel  
H = Hastelloy C-22®

**OPTIONAL FEATURES**

BL008 = Bleed Valve .008 Orifice  
BL015 = Bleed Valve .015 Orifice  
LK = LockOut-TagOut\*  
PM = Panel Mount\*\*  
VESP = Vespel® Seat\*\*\*  
PEEK = PEEK™ Seat  
2.78 = 2.78" End-To-End (1/4" FS Only)

**CONNECTIONS**

FSMM = 1/4" Face Seal, Male in-Male out  
FSFF = 1/4" Face Seal, Female in-Female out  
FSFM = 1/4" Face Seal, Female in-Male out  
FSMF = 1/4" Face Seal, Male in-Female out  
FS8MM= 1/2" Face Seal, Male in-Male out  
FS8FF = 1/2" Face Seal, Female in-Female out  
FS8FM= 1/2" Face Seal, Female in-Male out  
FS8MF= 1/2" Face Seal, Male in-Female out  
TS = 1/4" Tube Stub  
TS6 = 3/8" Tube Stub  
TS8 = 1/2" Tube Stub

\* LockOut-TagOut Clamp for M Type Valves  
LockOut-TagOut Bracket for G Type Valves  
\*\* Not available with Indicating Handwheel (I)  
\*\*\* Recommended for Nitrous Oxide (N<sub>2</sub>O) Service

Note: See Valve Selection Guide for multiple porting selections.

Hastelloy C-22® is a registered trademark of Haynes International, Inc.  
Vespel® is a registered trademark of DuPont Company.  
Elgiloy® is a registered trademark of Elgiloy Company.  
PEEK™ is a registered trademark of Victrex plc.



Parker Hannifin Corporation's Veriflo Division presents the Quantum 955 Air-Operated diaphragm valve. The 955AOPLP is ideal for low vapor pressure gasses such as WF6 and BCL3.



### features

- ▶ .55 Cv flow capacity.
- ▶ "VeriClean" low sulfur high purity 316L VAR Stainless Steel™, which enhances electropolishing, welding, and corrosion resistance.
- ▶ Internally threadless and springless.
- ▶ Fully functional from vacuum to 125 psig.
- ▶ Ideal for low vapor pressure gasses.
- ▶ Aerodynamic, smooth flow passages.
- ▶ Minimum particle generation and entrapment.
- ▶ High cycle life (including corrosive service).
- ▶ 100% Helium leak tested.
- ▶ "Hurricane" cleaning, proprietary cleaning process, removes metallic ions, organic films and surface adhering particles.

### materials of construction

#### Wetted

Body . . . . . "VeriClean", Veriflo's custom high purity type 316L VAR Stainless Steel™, Hastelloy C-22®  
Seat. . . . . PCTFE, optional Vespel®, PEEK™  
Diaphragm. . . . . Elgiloy® or equivalent

#### Non-Wetted

Nut . . . . . 316L Stainless Steel  
Cap . . . . . 316L Stainless Steel  
Actuator Housing . . . . . Aluminum

### operating conditions

Maximum operating pressure 125 psig (8.6 barg)

Minimum operating pressure. . . . . Vacuum

Temperature . . . . -40°F to 150°F (-40°C to 66°C)

Bake out . . . . 250°F (121°C) in the open position

Actuator pressure. . . . . 60-120 psig (4-8.3 barg)

### functional performance

Flow capacity . . . . .  $C_v = .55$   
(SEMI Flow Coefficient Test #F-32-0998)

Design Leak Rate:

Outboard . . . . .  $1 \times 10^9$  scc/sec He

Inboard . . . . .  $2 \times 10^{10}$  scc/sec He

Across seat . . . . .  $4 \times 10^9$  scc/sec He

### standard connections

Any combination of 1/4" FS male and/or female fittings:

Gland to gland length . . . . . 2.96 in. (75.1 mm)

Optional . . . . . 2.78 in. (70.6 mm)

Tube stubs inlet and outlet:

End to end length . . . . . 2.25 in. (57.1 mm)

Other configurations available as options— including as many as four ports. see Valve Selection Guide

### internal volume

3.29 cc (including face seal fittings)

### surface finishes

Standard Ra . . . . . 5 micro inch (.13 micro meter) or less

### approximate weight

.81 lbs (.36 kg)

# QUANTUM 955AOPLP

## Dimensional Drawing

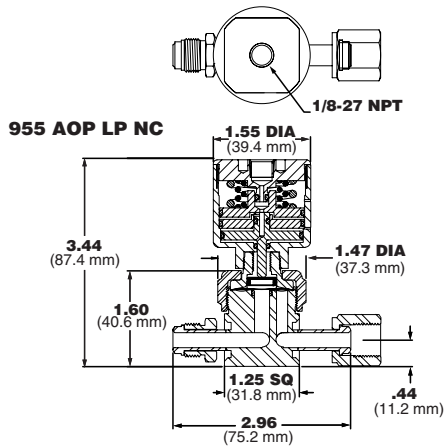

SEE TABLE FOR OTHER CONNECTION DIMENSIONS

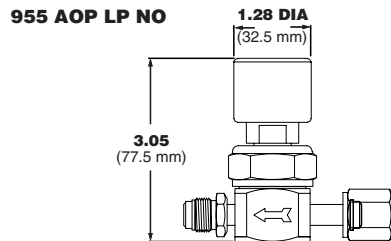
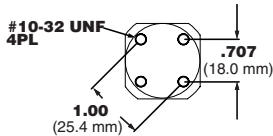

## Flow Curve

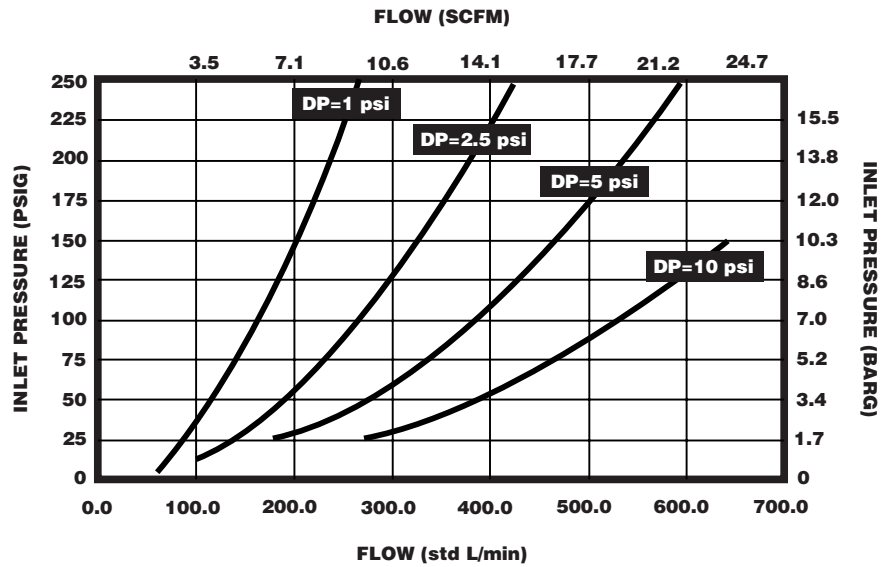

Connection	End to End Length
1/4" FS	2.96" (75.1 mm) STD
1/4" FS	2.78" (70.6 mm) Optional
1/4" TS	2.25" (57.1 mm) STD
3/8" TS6	2.25" (57.1 mm) STD
1/2" TS8	2.25" (57.1 mm) STD
1/2" FS8	4.20 (106.7 mm) STD

## Ordering Information

955AOPLP NC S FSMM VESP

### BASIC SERIES

955AOPLP = 955 Air Operated, Low Pressure

### TYPE

NC = Normally Closed  
NO = Normally Open

### MATERIAL

S = 316L VAR Stainless Steel  
H = Hastelloy C-22®

\* Recommended for Nitrous Oxide (N<sub>2</sub>O) Service

Note: Refer to Valve Selection Guide for multiple porting selections.

Hastelloy C-22® is a registered trademark of Haynes International, Inc.  
Vespe® is a registered trademark of DuPont Company.  
Viton® is a registered trademark of DuPont Elastomers Company.  
Elgiloy® is a registered trademark of Elgiloy Company.  
PEEK™ is a registered trademark of Vitrex plc.

### OPTIONAL FEATURES

BL008 = Bleed Valve .008 Orifice  
BL015 = Bleed Valve .015 Orifice  
LS = Limit Switch  
PEEK = PEEK™ Seat  
VESP = Vespe® Seat\*  
2.78 = 2.78" End-To-End (1/4" FS Only)

### CONNECTIONS

FSMM = 1/4" Face Seal, Male in-Male out  
FSFF = 1/4" Face Seal, Female in-Female out  
FSFM = 1/4" Face Seal, Female in-Male out  
FSMF = 1/4" Face Seal, Male in-Female out  
FS8MM = 1/2" Face Seal, Male in-Male out  
FS8FF = 1/2" Face Seal, Female in-Female out  
FS8FM = 1/2" Face Seal, Female in-Male out  
FS8MF = 1/2" Face Seal, Male in-Female out  
TS = 1/4" Tube Stub  
TS6 = 3/8" Tube Stub  
TS8 = 1/2" Tube Stub



# QUANTUM 955Y

## High Purity, High Flow Manifold Valve



Parker Hannifin Corporation's Veriflo Division presents the 955Y. The 955Y is a custom built high-purity, high-flow diaphragm valve manifold, engineered to meet the specific requirements of semiconductor OEM tool manufacturer and point-of-use gas delivery systems.

The 955 Y is a sophisticated design with Veriflo's proven ultra high purity, low internal volume components. Space savings and fewer welds make the 955Y ideal for process control and purge systems.



### features

- ▶ High cycle life.
- ▶ Ideal for valve manifold boxes (VMB).
- ▶ Ultra high performance.
- ▶ Change over from normally closed (NC) to normally open (NO) without intruding into wetted area.
- ▶ Fully functional under vacuum conditions.
- ▶ Large Cv ideal for low vapor pressure gases such as WF<sub>6</sub> and chlorinated gases such as HCl, Cl<sub>2</sub> and BCl<sub>3</sub>.



### materials of construction

#### Wetted

Body . . . . . "VeriClean", Veriflo's custom high purity Type 316L VAR Stainless Steel™  
Seal . . . . . PCTFE, optional Vespel®, PEEK™  
Diaphragm . . . . . Elgiloy® or equivalent

#### Non-wetted

Nut . . . . . 316L stainless steel  
Cap . . . . . 316L stainless steel

#### Actuator material

Body . . . . . Anodized aluminum  
Pistons . . . . . Brass  
O-ring seals . . . . . Viton®

### operating conditions

Maximum operating pressure:  
AOPLPNCNO . . . . . 125 psig (8.6 barg)  
Manual . . . . . 125 psig (8.6 barg)  
Minimum operating pressure . . . . . Vacuum  
For oxygen . . . . . Refer to CGA G-4.4  
Industrial Practices for Gaseous Oxygen  
Temperature . . . . -40°F to 150°F (-40°C to 66°C)  
Bakeout . . . . 250°F (121°C) in the open position

### surface finishes

Standard Ra . . . . . 10 micro inch  
(.25 micro meter) or less  
Optional Ra . . . . . EV=5 micro inch  
(.13 micro meter) or less

### functional performance

Flow capacity . . . . . C<sub>v</sub> 0.43 Process valve  
(SEMI Flow Coefficient Test #F-32-0998)  
Purge Valve . . . . . C<sub>v</sub> 0.35

#### Design Leak Rate:

Across Seat . . . . . 4 x 10<sup>9</sup> scc/sec He  
Inboard . . . . . 2 x 10<sup>10</sup> scc/sec He  
Outboard . . . . . 1 x 10<sup>9</sup> scc/sec He

### standard connections

Any combination of FS male and / or female fittings:  
1/4" Gland to gland length . . . . . 4.69 or 4.06  
(see dimensional drawing)

1/4" tube stubs inlet and outlet available:  
End to end length: . . . . . 3.62

### internal volume

4.49 cc

### approximate weight

2.11 lbs (0.98 kgm)

# QUANTUM 955Y

## Cross Sectional Drawings

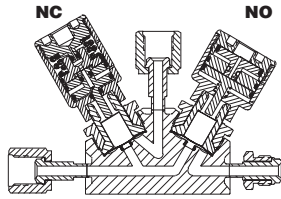

955Y1NO/NCFSMFFA

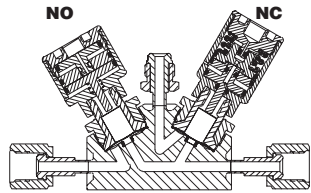
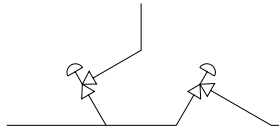

955Y2NC/NOFSMFFA

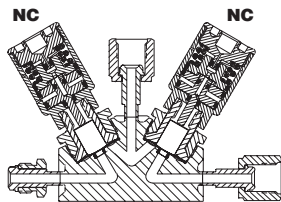
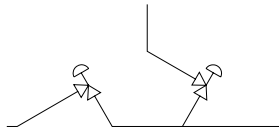

955Y3NC/NCFSFFMA

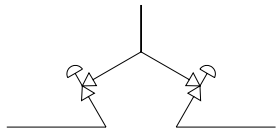

## Dimensional Drawings

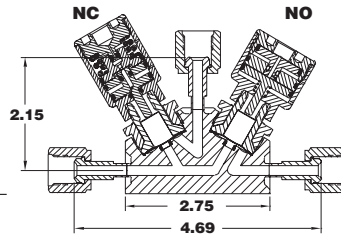

955Y1NO/NCFSFFFA

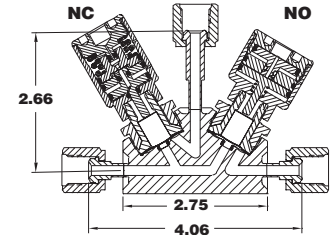

955Y1NO/NCFSFFFB

## Ordering Example

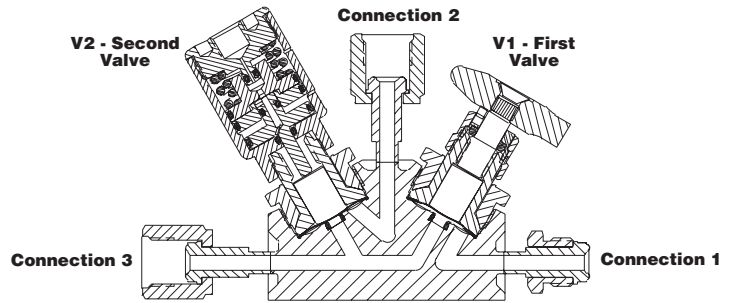

955Y1M/NCFSMFFA

## Ordering Information

### BASIC SERIES

955Y

### FLOW PATH

- 1 = Down Stream Purge
- 2 = Up Stream Purge
- 3 = Common

### TYPE (V1/V2)

- NC = AOP LP Normally Closed
- NO = AOP LP Normally Open
- M = Mini Lever
- I = Indicating Handwheel

\* Recommended for Nitrous Oxide (N<sub>2</sub>O) Service

Hastelloy C-22® is a registered trademark of Haynes International, Inc.  
 Kel-F 81® is a registered trademark of 3M Company.  
 Vespel® is a registered trademark of DuPont Company.  
 Viton® is a registered trademark of DuPont Elastomers Company.  
 Elgiloy® is a registered trademark of Elgiloy Company.  
 PEEK™ is a registered trademark of Victrex plc.

955Y 1 NO/NC FS MFF TH A

### DIMENSIONS

- A = 4.69 x 2.15 (FS M or FS F)
- B = 4.06 x 2.66 (FS F only)

### OPTIONAL FEATURES

- VESP = Vespel®\*
- PEEK™ = PEEK™ Seat

### PORT CONFIGURATION

- M = Face Seal Male
- F = Face Seal Female

### PORT STYLE

- FS = 1/4" Face Seal
- TS = 1/4" Tube Stub

## Flow Curve

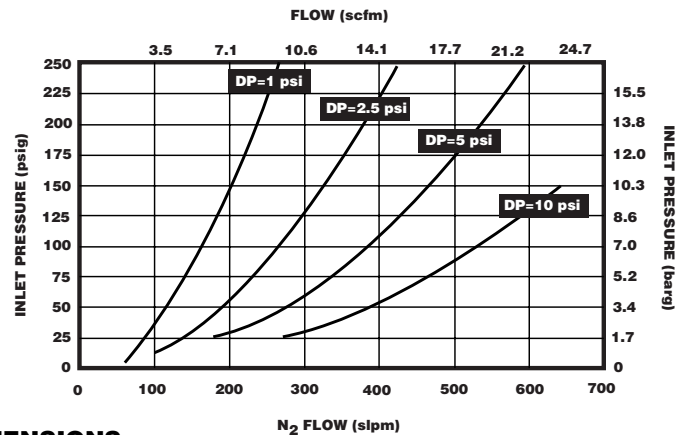

# TITAN II® AOP PLUS High Pressure Diaphragm Valve



Parker Hannifin Corporation's Veriflo Division presents the TITAN II® AOP Plus high pressure diaphragm valve. The TITAN II® AOP is specifically designed for high pressure, high cycle, ultra high purity applications.



## features

- ▶ "VeriClean", Veriflo's custom high purity Type 316L Stainless Steel™
- ▶ Springless, stemless design.
- ▶ Metal diaphragm sealed.
- ▶ Back panel mounting capabilities.
- ▶ High cycle life.
- ▶ Fully swept flow path.
- ▶ Standard 6 inch micro Ra (0.15 micro meter), EP Surface Finish.
- ▶ 100% Helium leak tested.
- ▶ Reduced seat volume.
- ▶ Normally open and normally closed designs from vacuum to 3000 psig (207 barg)

Actuator Pressure vs. System Pressure (Minimum Values)

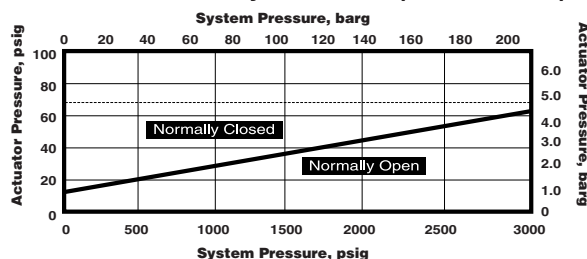

## materials of construction

### Wetted

Body . . . . . "VeriClean", Veriflo's custom high purity Type 316L Stainless Steel™ optional Hastelloy C-22® or Nickel 200  
 Seat . . . . . PCTFE, optional Vespel®  
 Diaphragm . . . . . Elgiloy®

### Non-wetted

Actuator Housing . . . . . Aluminum

## operating conditions

Maximum operating pressure . . . . . 3000 psig (207 barg)  
 Minimum operating pressure . . . . . Vacuum

### AOP Actuation:

Normally Closed . . . . . 70 to 125 psig (4.8 to 8.6 bar)  
 Normally Open . . . . . 70 to 125 psig (4.8 to 8.6 bar)

See Chart Below

### Temperature:

PCTFE Seat . . . . . -65°F to 150°F (-54°C to 65°C)  
 Vespel® Seat . . . . . -65°F to 250°F (-54°C to 121°C)

## functional performance

Flow Capacity . . . . . C<sub>v</sub> 0.25

### Design Leak Rate:

Outboard . . . . . 1x10<sup>-9</sup> scc/sec He  
 Inboard . . . . . 1x10<sup>-9</sup> scc/sec He  
 Across seat . . . . . 1x10<sup>-9</sup> scc/sec He

## internal volume

1.55 cc

## surface finishes

Standard Ra . . . . . 6 micro inch Ra (0.15 micro meter) EP surface finish





# TITAN II® AOP PLUS

## Dimensional Drawings

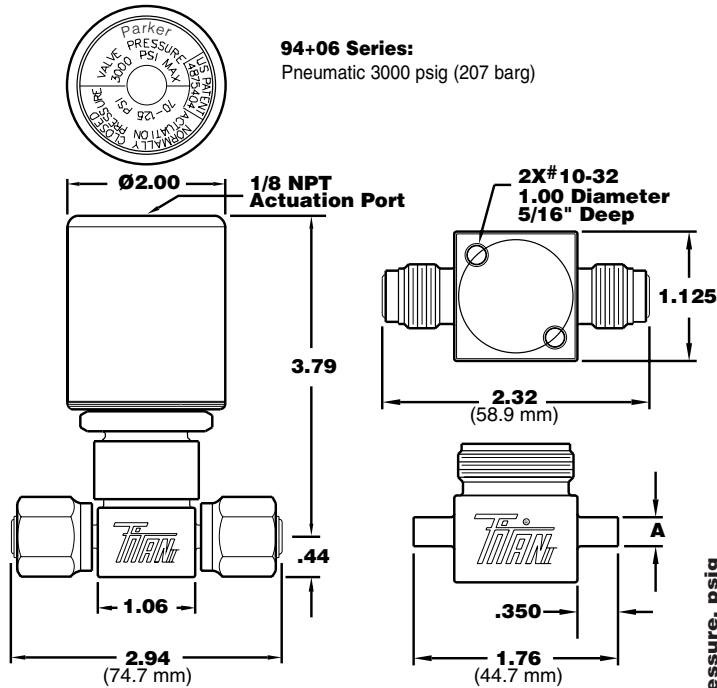

End Connections	Designator	End to End "L" in (mm)	"A" O.D. in (mm)
1/4" Tube Weld	TWTW	1.76 (44.7)	1/4 (6.4)
3/8" Tube Weld	TWTW	1.76 (44.7)	3/8 (9.5)
1/4" VacuSeal™ Male	VMVM	2.31(58.6)	-
1/4" VacuSeal™ Female	VFVF	2.94 (74.7)	-
1/4" VacuSeal™ Male	VMSVMS	3.94 (100.1)	-

Dimensions are for reference only.

## Flow Curves

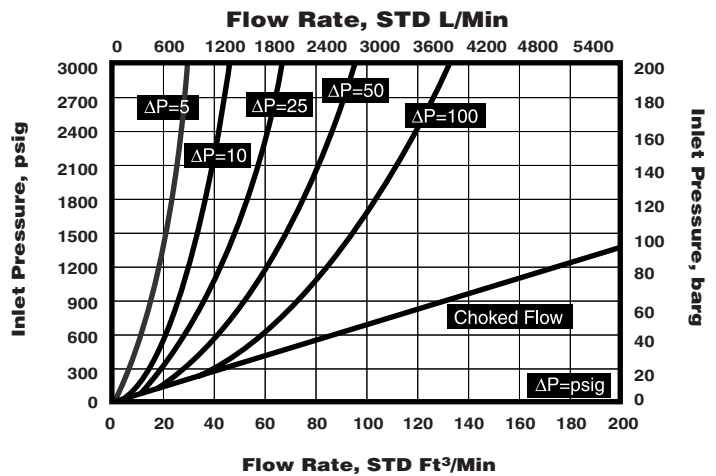

## Ordering Information

94 + 06 4 4 2 TW TW - NO

### SERIES

94+06 Series = Pneumatic Actuated  
3000 psig (207 barg)

### INLET PORT SIZE

4 = 1/4"  
6 = 3/8"

### OUTLET PORT SIZE

4 = 1/4"  
6 = 3/8"

### MATERIAL

2 = 316L Stainless Steel  
16 = Hastelloy C-22®  
31 = Nickel

### INLET CONNECTION

TW = Tube Weld  
VF = VacuSeal™ Female  
VM = VacuSeal™ Male (1/4")  
VMS = VacuSeal™ Male Swivel

### OPTIONAL FEATURES

CB1 = Constant Bleed 1 slpm  
CB3 = Constant Bleed 3 slpm  
PI = Vespel® Seat†  
PTFE Seat (Standard) Leave Blank  
NO = Normally Open Actuator  
Normally Closed Actuator (Standard) Leave Blank

### OUTLET CONNECTION

TW = Tube Weld  
VF = VacuSeal™ Female  
VM = VacuSeal™ Male (1/4")  
VMS = VacuSeal™ Male Swivel

### † Recommended for Nitrous Oxide (N<sub>2</sub>O) Service

VacuSeal™ is a trademark of Parker Hannifin Corporation.  
Elgiloy® is a registered trademark of Elgiloy Corporation.  
Hastelloy® is a registered trademark of Haynes International.  
Vespel® is a registered trademark of DuPont Company.

# TITAN II® AOP PLUS

**Medium Pressure Diaphragm Valve**



Parker Hannifin Corporation's Veriflo Division presents the TITAN II® AOP Plus medium pressure diaphragm valve. The TITAN II AOP® is specifically designed for medium pressure, medium cycle, ultra high purity applications.



## features

- ▶ "VeriClean", Veriflo's custom high purity Type 316L Stainless Steel™
- ▶ Springless, stemless design.
- ▶ Metal diaphragm sealed.
- ▶ Back panel mounting capabilities.
- ▶ High cycle life.
- ▶ Fully swept flow path.
- ▶ Standard 6 inch micro Ra (0.15 micro meter), EP Surface Finish.
- ▶ 100% Helium leak tested.
- ▶ Reduced seat volume.
- ▶ Normally open and normally closed designs from vacuum to 300 psig (20.7 barg)

**Actuator Pressure vs. System Pressure (Minimum Values)**

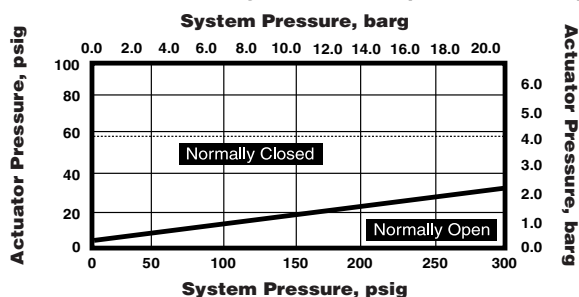

## materials of construction

### Wetted

Body . . . . . "VeriClean", Veriflo's custom high purity Type 316L Stainless Steel™ optional Hastelloy C-22® or Nickel 200  
 Seat . . . . . PCTFE, optional Vespel®  
 Diaphragm . . . . . Elgiloy®

### Non-wetted

Actuator Housing . . . . . Aluminum

## operating conditions

Maximum operating pressure . . . . . 300 psig (20.7 barg)

Minimum operating pressure . . . . . Vacuum

### AOP Actuation:

Normally Open . . . . . 70 to 125 psig (4.8 to 8.6 bar)  
 Normally Closed . . . . . 70 to 125 psig (4.8 to 8.6 bar)

See chart below

### Temperature:

PCTFE Seat . . . . . -65°F to 150°F (-54°C to 65°C)  
 Vespel® Seat . . . . . -65°F to 250°F (-54°C to 121°C)

## functional performance

Flow Capacity . . . . . C<sub>v</sub> 0.25

### Design Leak Rate:

Outboard . . . . . 1x10<sup>-9</sup> scc/sec He  
 Inboard . . . . . 1x10<sup>-9</sup> scc/sec He  
 Across seat . . . . . 1x10<sup>-9</sup> scc/sec He

## internal volume

1.55 cc

## surface finishes

Standard Ra . . . . . 6 micro inch Ra (0.15 micro meter) EP surface finish



# TITAN II® AOP PLUS

## Dimensional Drawings

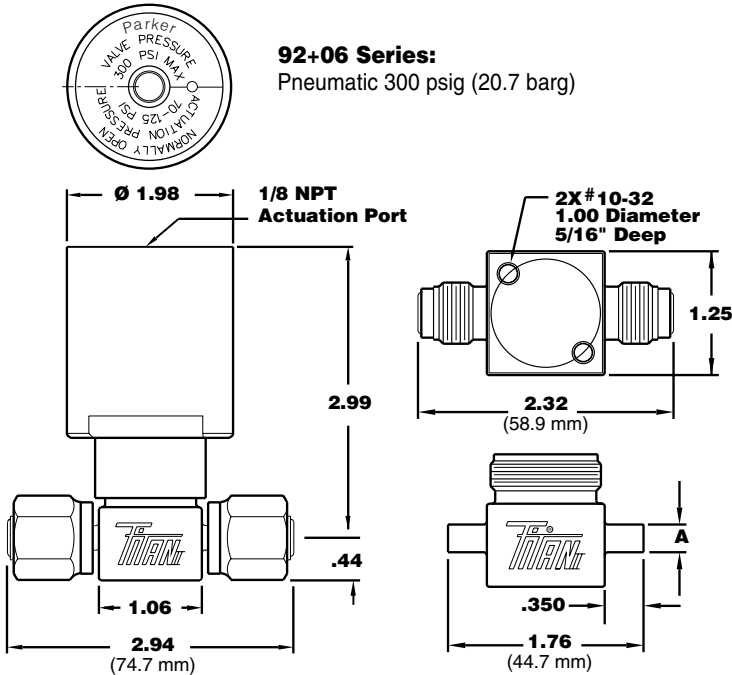

**92+06 Series:**  
Pneumatic 300 psig (20.7 barg)

End Connections	Designator	End to End "L" in (mm)	"A" O.D. in (mm)
1/4" Tube Weld	TWTW	1.76 (44.7)	1/4 (6.4)
3/8" Tube Weld	TWTW	1.76 (44.7)	3/8 (9.5)
1/4" VacuSeal™ Male	VMVM	2.31 (58.6)	-
1/4" VacuSeal™ Female	VFVF	2.94 (74.7)	-
1/4" VacuSeal™ Male	VMSVMS	3.94 (100.1)	-

Dimensions are for reference only.

## Flow Curves

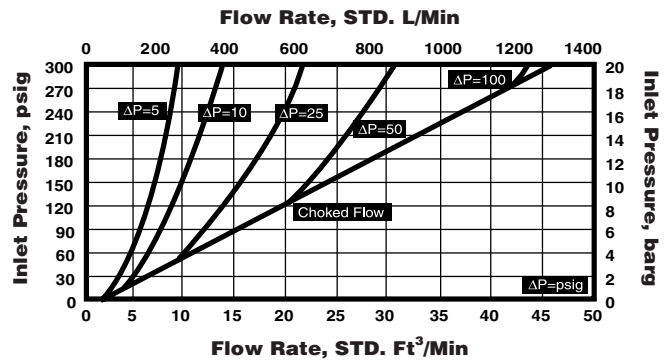

## Ordering Information

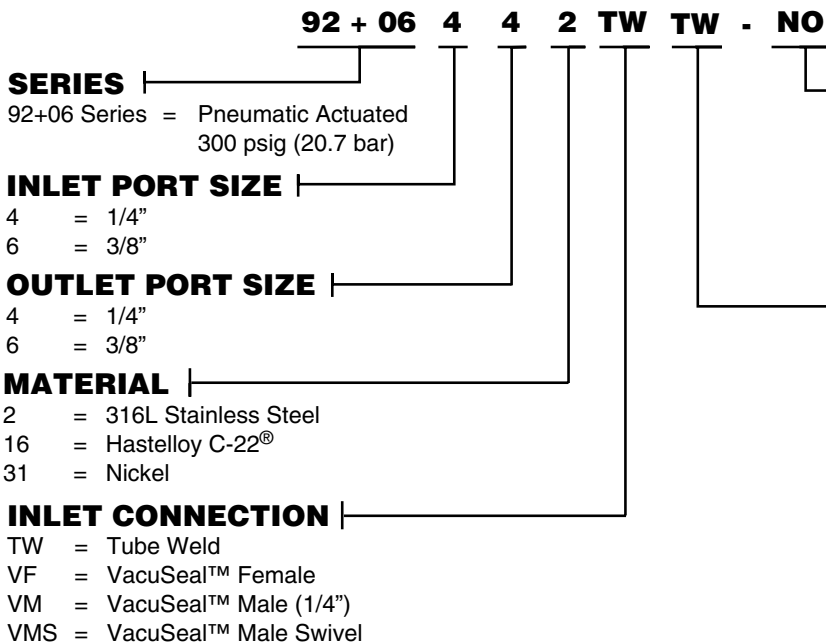

### OPTIONAL FEATURES

- CB1 = Constant Bleed 1 slpm
- CB3 = Constant Bleed 3 slpm
- PI = Vespel® Seat†
- PCTFE Seat (Standard) Leave Blank
- NO = Normally Open Actuator
- Normally Closed Actuator (Standard) Leave Blank

### OUTLET CONNECTION

- TW = Tube Weld
- VF = VacuSeal Female
- VM = VacuSeal Male (1/4")
- VMS = VacuSeal Male Swivel

### † Recommended for Nitrous Oxide (N<sub>2</sub>O) Service

VacuSeal™ is a trademark of Parker Hannifin Corporation.  
Elgiloy® is a registered trademark of Elgiloy Corporation.  
Hastelloy® is a registered trademark of Haynes International.  
Vespel® is a registered trademark of DuPont Company.

# TITAN II® AOP PLUS Low Pressure Diaphragm Valve



Parker Hannifin Corporation's Veriflo Division presents the TITAN II® AOP Plus low pressure diaphragm valve. TITAN II® AOP is specifically designed for low pressure, low cycle, ultra high purity applications.



## features

- ▶ "VeriClean", Veriflo's custom high purity Type 316L Stainless Steel™
- ▶ Springless, stemless design.
- ▶ Metal diaphragm sealed.
- ▶ Back panel mounting capabilities.
- ▶ High cycle life.
- ▶ Fully swept flow path.
- ▶ Standard 6 inch micro Ra (0.15 micro meter), EP Surface Finish.
- ▶ 100% Helium leak tested.
- ▶ Reduced seat volume.
- ▶ Normally open and normally closed designs from vacuum to 150 psig (10.5 barg).

**Actuator Pressure vs. System Pressure (Minimum Values)**

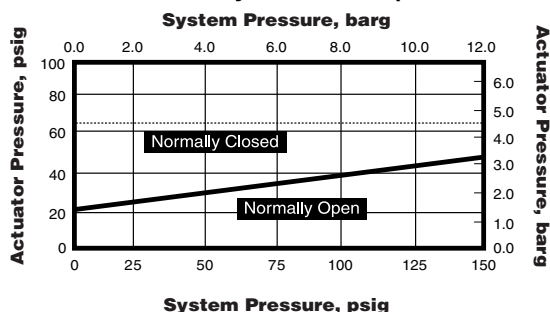

## materials of construction

### Wetted

Body . . . . . "VeriClean", Veriflo's custom high purity Type 316L Stainless Steel™ optional Hastelloy C-22® or Nickel 200  
 Seat . . . . . PCTFE, optional Vespel®  
 Diaphragm . . . . . Elgiloy®

### Non-wetted

Actuator Housing . . . . . Aluminum

## operating conditions

Maximum operating pressure . . . . . 150 psig (10.5 barg)

Minimum operating pressure rating . . . Vacuum

### AOP Actuation:

Normally Open . . . . . 70 to 125 psig (4.8 to 8.6 barg)

Normally Closed . . . . . 70 to 125 psig (4.8 to 8.6 barg)

See chart below

### Temperature:

PCTFE Seat . . . . . -65°F to 150°F (-54°C to 65°C)

Vespel® Seat . . . . . -65°F to 250°F (-54°C to 121°C)

## functional performance

Flow Capacity . . . . . Cv 0.25

### Design Leak Rate:

Outboard . . . . . 1x10<sup>9</sup> scc/sec He

Inboard . . . . . 1x10<sup>9</sup> scc/sec He

Across seat . . . . . 1x10<sup>9</sup> scc/sec He

## internal volume

1.55 cc

## surface finishes

Standard Ra . . . . . 6 micro inch Ra (0.15 micro meter) EP surface finish



# TITAN II® AOP PLUS

## Dimensional Drawings

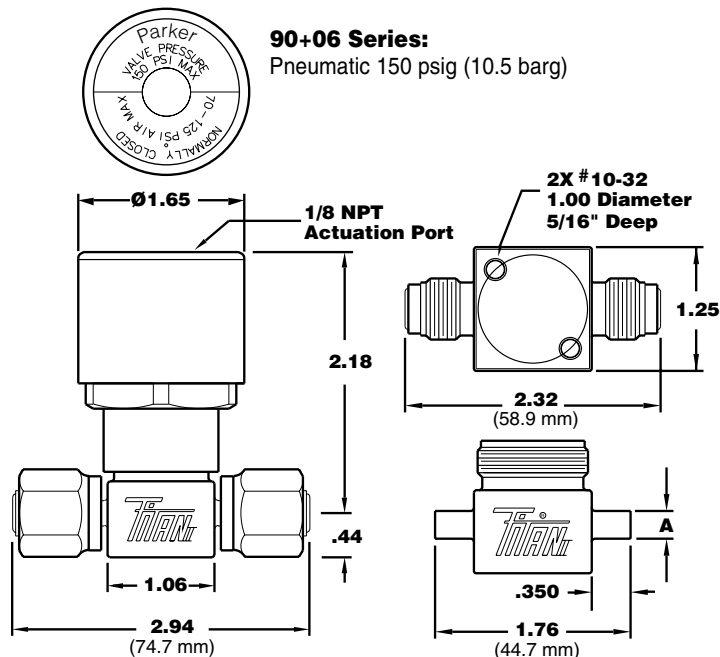

End Connections	Designator	End to End "L" in (mm)	"A" O.D. in (mm)
1/4" Tube Weld	TWTW	1.76 (44.7)	1/4 (6.4)
3/8" Tube Weld	TWTW	1.76 (44.7)	3/8 (9.5)
1/4" VacuSeal™ Male	VMVM	2.31 (58.6)	-
1/4" VacuSeal™ Female	VVVF	2.94 (74.7)	-
1/4" VacuSea™ Male	VMSVMS	3.94 (100.1)	-

Dimensions are for reference only.

## Flow Curves

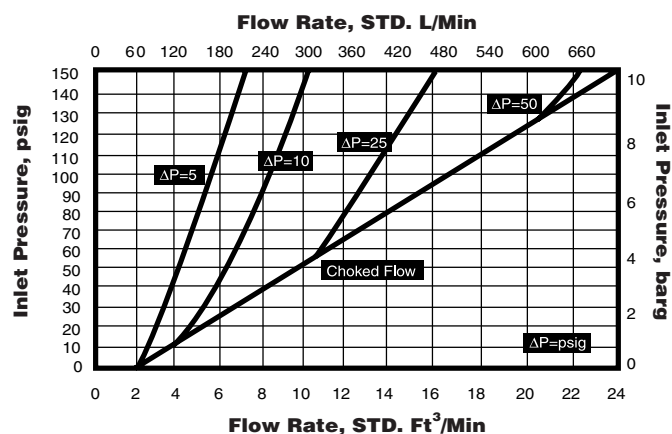

## Ordering Information

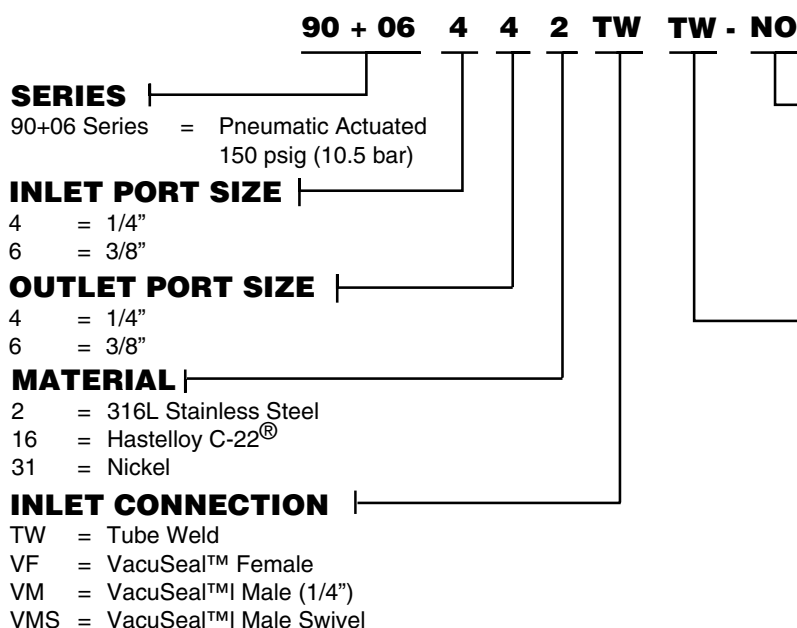

### OPTIONAL FEATURES

- CB1 = Constant Bleed 1 slpm
- CB3 = Constant Bleed 3 slpm
- PI = Vespel® Seat†
- PCTFE Seat (Standard) Leave Blank
- NO = Normally Open Actuator
- Normally Closed Actuator (Standard) Leave Blank

### OUTLET CONNECTIONS

- TW = Tube Weld
- VF = VacuSeal™ Female
- VM = VacuSeal™ Male (1/4")
- VMS = VacuSeal™ Male Swivel

### † Recommended for Nitrous Oxide (N<sub>2</sub>O) Service

VacuSeal™ is a trademark of Parker Hannifin Corporation.  
Elgiloy® is a registered trademark of Elgiloy Corporation.  
Hastelloy® is a registered trademark of Haynes International.  
Vespel® is a registered trademark of DuPont Company.





Parker Hannifin Corporation's Veriflo Division presents the TITAN II<sup>®</sup> Manual Plus, springless diaphragm valve, which is specifically designed for high pressure, high cycle, and ultra high purity applications.



### features

- ▶ “VeriClean”, Veriflo's custom high purity Type 316L Stainless Steel™.
- ▶ Springless, stemless design.
- ▶ Metal diaphragm sealed.
- ▶ Back panel mounting capabilities.
- ▶ High cycle life.
- ▶ Fully swept flow path.
- ▶ Standard 6 inch micro Ra (0.15 mm), EP Surface Finish.
- ▶ 100% Helium leak tested.
- ▶ Reduced seat volume.
- ▶ Position changeable 1/4 turn lever handle.

### materials of construction

#### Wetted

Body . . . . . “VeriClean”, Veriflo's custom high purity Type 316L Stainless Steel™ optional Hastelloy C-22<sup>®</sup> or Nickel 200  
 Seat . . . . . PCTFE, Optional Vespel<sup>®</sup>

#### Non-wetted

Bonnet . . . . . 303 Stainless Steel  
 Handle . . . . . Aluminum

### operating conditions

Maximum operating pressure . . . . . 3000 psig (207 barg)  
 Minimum operating pressure . . . . . Vacuum

#### Temperature:

PCTFE Seat . . . . . -65°F to 150°F (-54°C to 65°C)  
 Vespel<sup>®</sup> Seat . . . . . -65°F to 250°F (-54°C to 121°C)

### functional performance

Flow capacity . . . . . C<sub>v</sub> 0.25  
 Design Leak Rate:  
 Outboard . . . . . 1x10<sup>-9</sup> scc/sec He  
 Inboard . . . . . 1x10<sup>-9</sup> scc/sec He  
 Across seat . . . . . 1x10<sup>-9</sup> scc/sec He

### internal volume

1.55 cc

### surface finishes

Standard Ra . . . . . 6 micro inch Ra (0.15 micro meter) EP surface finish

# TITAN II<sup>®</sup> MANUAL PLUS

## Dimensional Drawings

**06 - Series**  
1/2 & 1/4 Turn  
Round Handle

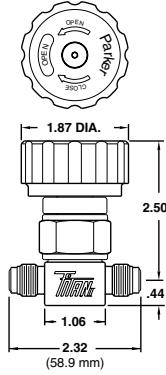

**07 - Series:**  
1/4 Turn Lever Handle

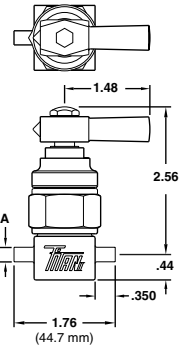

**07L - Series:**  
1/4 Turn Lever Indicator  
Positional Handle

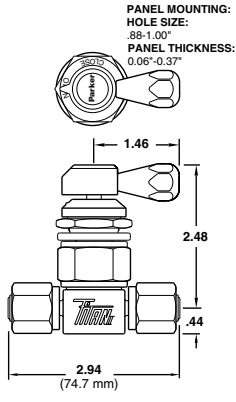

PANEL MOUNTING:  
HOLE SIZE:  
.88-1.00"  
PANEL THICKNESS:  
0.06"-0.37"

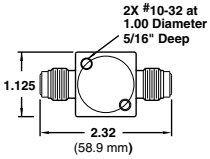

End Connections	Designator	End to End "L" in (mm)	"A" O.D. in (mm)
1/4" Tube Weld	TWTW	1.76 (44.7)	1/4 (6.4)
3/8" Tube Weld	TWTW	1.76 (44.7)	3/8 (9.5)
1/4" VacuSeal Male	VMVM	2.32 (58.9)	-
1/4" VacuSeal Female	VFVF	2.96 (75.2)	-
1/4" VacuSeal Male Swivel Nut	VMSVMS	3.94 (100.1)	-

Dimensions are for reference only.

## Flow Curves

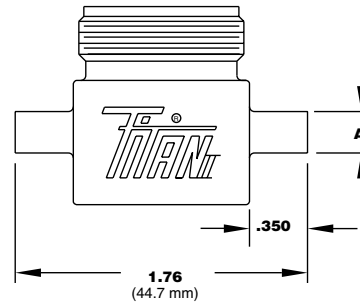
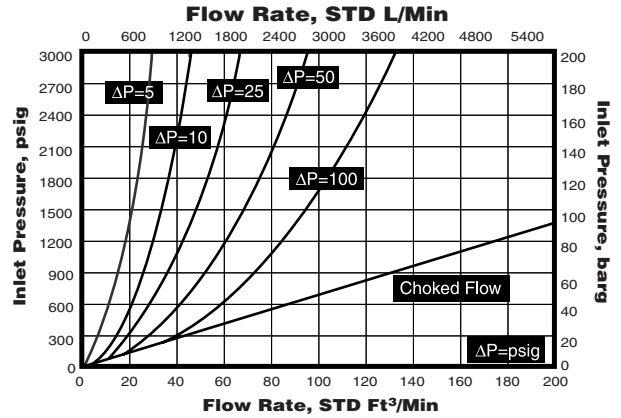

## Ordering Information

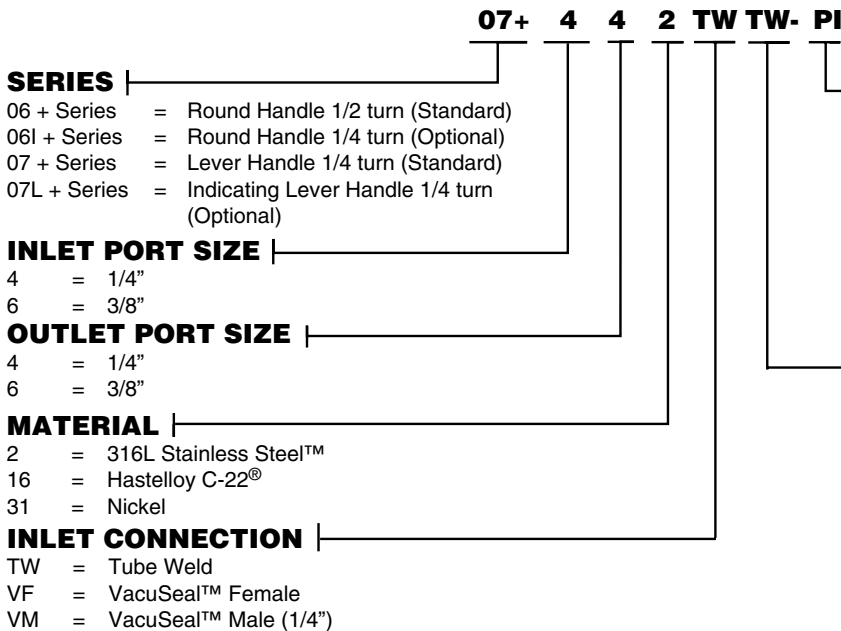

### OPTIONAL FEATURES

- CB1 = Constant Bleed 1 slpm
- CB3 = Constant Bleed 3 slpm
- PI = Vespel<sup>®</sup> Seat†
- PCTFE Seat - Standard - Leave Blank
- RD = Red Handle
- WH = White Handle
- Blue Handle - Standard - Leave Blank

Note: Consult factory for additional handle options.

### OUTLET CONNECTION

- TW = Tube Weld
- VF = VacuSeal™ Female
- VM = VacuSeal™ Male (1/4")
- VMS = VacuSeal™ Male Swivel

†Recommended for Nitrous Oxide (N<sub>2</sub>O) Service

VacuSeal™ is a trademark of Parker Hannifin Corporation.  
Elgiloy<sup>®</sup> is a registered trademark of Elgiloy Corporation.  
Hastelloy<sup>®</sup> is a registered trademark of Haynes International.  
Vespel<sup>®</sup> is a registered trademark of DuPont Company.

Notes: Consult factory for additional Connection options



# TITAN II® MS

## All Metal, High Pressure Diaphragm Valves



Parker Hannifin Corporation's Veriflo Division presents the TITAN II® MS manual, springless diaphragm valve, which is specifically designed for high temperature, high pressure, high cycle, and ultra high purity applications.



### features

- ▶ Springless stemless design.
- ▶ 6 Ra electropolished (EP) internal surface finish.
- ▶ Maximum allowable leakage: 1x10<sup>-9</sup> scc/sec Helium.
- ▶ "VeriClean", Veriflo's custom high purity Type 316L Stainless Steel™.
- ▶ Manual and pneumatically actuated designs. Actuator pressure to open 70 psig min to 125 psig max.

### materials of construction

#### Wetted

Body . . . . . "VeriClean", Veriflo's custom high purity Type 316L Stainless Steel™ optional Hastelloy C-22® or Nickel 200  
Seat . . . . . Integral Metal  
Diaphragm . . . . . Elgiloy®

#### Non-wetted

Bonnet . . . . . 303 Stainless Steel  
Handle . . . . . Aluminum

### operating conditions

Maximum operating pressure . . . . . 3000 psig (207 barg)  
Minimum operating pressure . . . . . Vacuum  
  
Maximum Temperature limit: . . . . . 150°F(65.5°C)  
  
AOP Actuation . . . . . -70 psig to 125 psig (4.8 barg to 8.6 barg)

### functional performance

Flow capacity . . . . . C<sub>v</sub> 0.27  
  
Design Leak Rate:  
Outboard . . . . . 1x10<sup>-9</sup> scc/sec He  
Inboard . . . . . 1x10<sup>-9</sup> scc/sec He  
Across seat . . . . . 1x10<sup>-9</sup> scc/sec He

### internal volume

1.55 cc

### surface finishes

Standard Ra . . . . . 6 micro inch Ra (0.15 micro meter) EP surface finish





# TITAN II® MS

## Dimensional Drawings

**06 - Series**  
1/2 & 1/4 Turn  
Round Handle

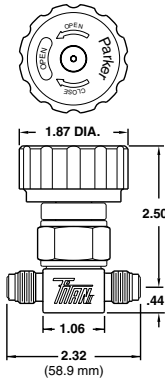

**07 - Series:**  
1/4 Turn Lever Handle

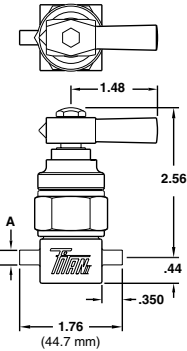

**07L - Series:**  
1/4 Turn Lever Indicator  
Positional Handle

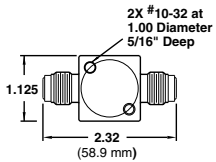
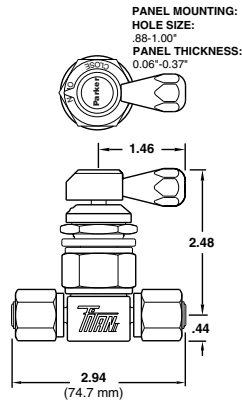

End Connections	Designator	End to End "L" in (mm)	"A" O.D. in (mm)
1/4" Tube Weld	TWTW	1.76 (44.7)	1/4 (6.4)
3/8" Tube Weld	TWTW	1.76 (44.7)	3/8 (9.5)
1/4" VacuSeal Male	VMVM	2.32 (58.9)	-
1/4" VacuSeal Female	VVVF	2.96 (75.2)	-
1/4" VacuSeal Male Swivel Nut	VMSVMS	3.94 (100.1)	-

Dimensions are for reference only.

## Flow Curves

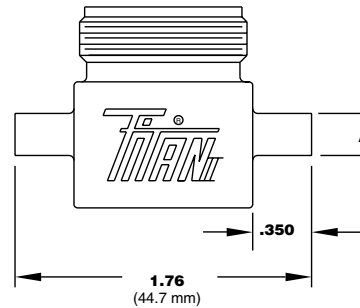
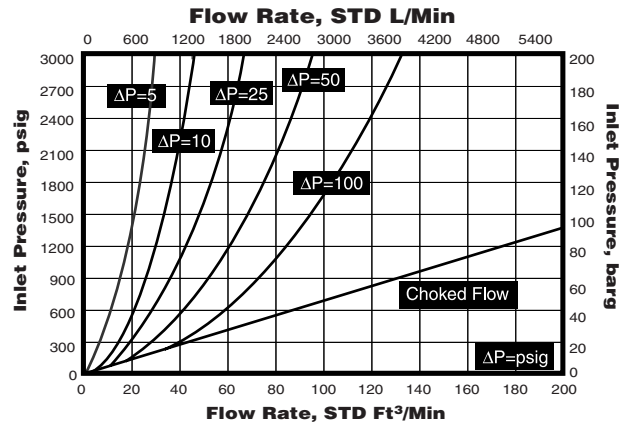

## Ordering Information

**07- 4 4 2 TW TW- MS**

### SERIES

- 06 - Series = Round Handle 1/2 turn (Standard)
- 06I - Series = Round Handle 1/4 turn (Optional)
- 07 - Series = Lever Handle 1/4 turn (Standard)
- 07L - Series = Indicating Lever Handle 1/4 turn (Optional)
- 94 - 06 = Pneumatic Actuator 3000 psig

### INLET PORT SIZE

- 4 = 1/4"
- 6 = 3/8"

### OUTLET PORT SIZE

- 4 = 1/4"
- 6 = 3/8"

### MATERIAL

- 2 = 316L Stainless Steel™
- 16 = Hastelloy C-22®
- 31 = Nickel

### INLET CONNECTION

- TW = Tube Weld
- VF = VacuSeal™ Female
- VM = VacuSeal™ Male (1/4")
- VMS = VacuSeal™ Male Swivel

**Notes:** Consult factory for additional Connection options

### OPTIONAL FEATURES

- CB1 = Constant Bleed 1 slpm
  - CB3 = Constant Bleed 3 slpm
  - MS = Metal Seat
  - Clear Handle - Standard - Leave Blank
- Note:** Consult factory for additional handle options.

### OUTLET CONNECTION

- TW = Tube Weld
- VF = VacuSeal™ Female
- VM = VacuSeal™ Male (1/4")
- VMS = VacuSeal™ Male Swivel

VacuSeal™ is a trademark of Parker Hannifin Corporation.  
Elgiloy® is a registered trademark of Elgiloy Corporation.  
Hastelloy® is a registered trademark of Haynes International.





Parker Hannifin Corporation's Veriflo Division presents the Quantum 928AOPHP. The 928AOPHP is a poppet-style diaphragm valve for remote control of gases or liquids.

The 928AOPHP serves two functions: it acts as the system inlet valve, and it reduces the system pressure to a safer working range.



## features

- ▶ "VeriClean", Veriflo's low sulfur high purity 316L VAR Stainless Steel™ enhances electropolishing, welding and corrosion resistance.
- ▶ Improves system safety by lowering or regulating system pressure to 350 psig.
- ▶ The 928 AOPHP is field-convertible, in place, to a 928 L (lever operated) valve by a simple exchange of non-wetted parts.
- ▶ Fully functional from a vacuum to 3500 psig inlet and outlet.
- ▶ Aerodynamic, smooth flow passages.
- ▶ Minimum particle generation and entrapment.
- ▶ 100% Helium leak tested.
- ▶ A unique patented compression member which loads the seal uniformly without the need for threaded components or crimping operations.
- ▶ "Hurricane" cleaning, optional proprietary cleaning process, removes metallic ions, organic films and surface adhering particles.

## materials of construction

### Wetted

Body . . . "VeriClean", Veriflo's custom high purity Type 316L VAR Stainless Steel™, Hastelloy C-22®  
 Seal . . . . . PCTFE, optional Vespel®  
 Diaphragm . . . . . Elgiloy® or equivalent  
 Poppet . . . . . 316L Stainless Steel, Hastelloy C-22®  
 Compression Member . . . . . 316L Stainless Steel, Hastelloy C-22®  
 Spring . . . . . Hastelloy C-22®  
 Screen . . . . . Hastelloy C-22®

### Non-Wetted

Nut . . . . . 316L Stainless Steel  
 Cap . . . . . 316L Stainless Steel

### Actuator Materials

Actuator Housing . . . . . Brass, Nickel Plated

## operating conditions

Maximum inlet pressure . . . 3500 psig (240 barg)  
 For Oxygen . . . . . 2200 psig (151 barg)  
 Minimum operating pressure . . . . . Vacuum  
 Nominal outlet pressure . . . . . 350 psig (24 barg)  
 with 2000 psig (138 barg) inlet pressure and 80 psig (5.5 barg) actuator pressure

Outlet pressure varies with inlet and actuator pressure

Temperature . . . . . -40°F to 150°F (-40°C to 66°C)  
 Bake out . . . . . 250°F (121°C) in the open position  
 Flow capacity . . . . .  $C_v = .04$

## functional performance

Design Leak Rate:  
 Outboard . . . . . Less than  $1 \times 10^{-9}$  scc/sec He  
 Inboard . . . . . Less than  $2 \times 10^{-10}$  scc/sec He  
 Across seat . . . . . Less than  $4 \times 10^{-9}$  scc/sec He  
 Design Proof Pressure . . . . . 5,250 psig (362 barg)  
 Design Burst Pressure . . . . . 10,500 psig (724 barg)

## standard configurations

Any combination of 1/4" FS male and/or female fittings  
 Gland to gland length . . . . . 2.78 in. (70.6 mm)  
 Optional . . . . . 3.06 in. (77.7 mm)  
 1/4 inch tube stubs inlet and outlet  
 End to end length . . . . . 1.75 in. (44.5 mm)  
 Other configurations available as options - including as many as five ports

## internal volume

1.86 cc (including face seal fittings)

## surface finishes

Standard Ra . . . . . 15-20 micro inch (.38 to .5 micro meter) or less  
 Optional Ra . . . . . EX=10 micro inch (.25 micro meter) or less

## approximate weight

1.1 lbs (.49 kg)



# QUANTUM 928AOPHP

## Dimensional Drawing

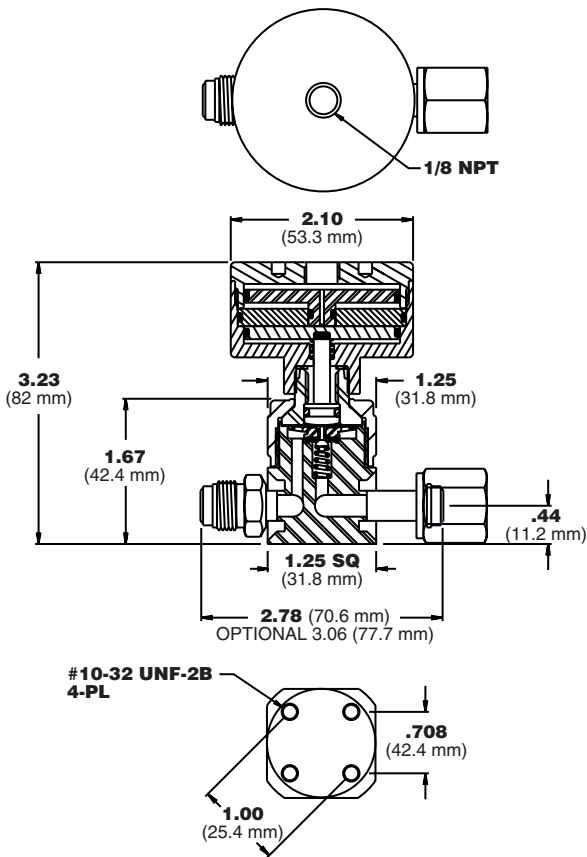

## Flow Curve

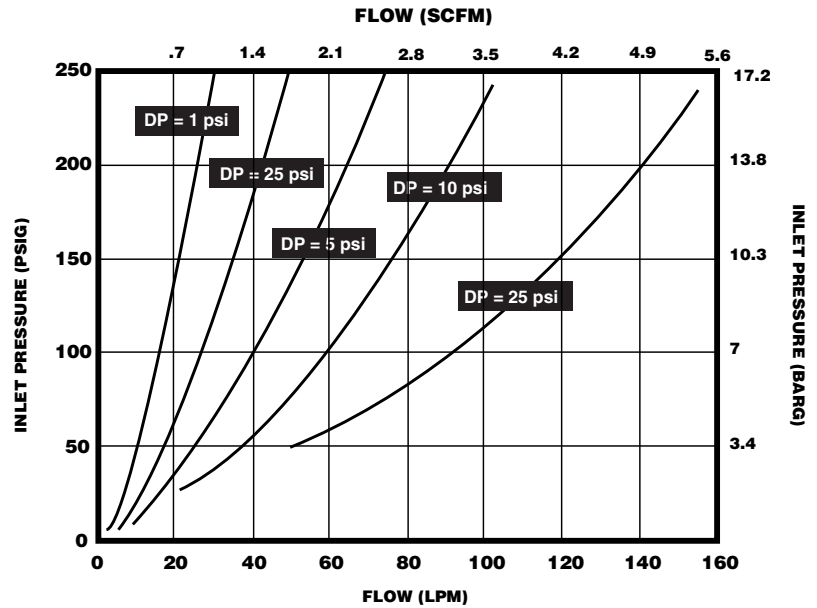

## Ordering Information

**928 AOPHP S FSMM VESP**

### BASIC SERIES

928

### TYPE

AOPHP = Air Operated High Pressure

### MATERIAL

H = Hastelloy C-22®\*

S = 316L VAR Stainless Steel

\* **Hastelloy C-22® Material Option includes: body, compression member, poppet, spring, and screen.**

\*\* **TH option includes: Hastelloy C-22® compression member, poppet, spring, and screen.**

\*\*\* **Recommended for Nitrous Oxide (N<sub>2</sub>O) Service.**

† **See Valve Selection Guide for multiple porting selections.**

### OPTIONAL FEATURES

TH = Hastelloy C-22® Trim \*\*

VESP = Vespel® Seat\*\*\*

### CONNECTIONS†

FSMM = 1/4" Face Seal, Male in-Male out

FSFF = 1/4" Face Seal, Female in-Female out

FSFM = 1/4" Face Seal, Female in-Male out

FSMF = 1/4" Face Seal, Male in-Female out

TS = 1/4" Tube Stub

P = 1/4" NPTF

Hastelloy C-22® is a registered trademark of Haynes International, Inc.

Kel-F 81® is a registered trademark of 3M Company.

Vespel® is a registered trademark of DuPont Company.

Elgiloy® is a registered trademark of Elgiloy Company.

Viton® is a registered trademark of DuPont Dow Elastomers Company

**Parker**  
Instrumentation

# LockOut-TagOut

**Safety  
Option**



Parker Hannifin Corporation's Veriflo Division presents the LockOut-TagOut safety option available for its standard diaphragm valve product line.

This design allows for tools or gas lines to be locked out for maintenance activities. This durable metal design can be used with confidence while doing repairs.



► **materials of construction**

Clamp . . . . . ZA-27 alloy casting  
Powder coat (Red)  
Nut . . . . . 303 Stainless Steel  
Washer . . . . . 304 Stainless Steel Annealed  
Dowel Pin . . . . . Stainless Steel 18-8

*Note: Refer to individual valve literature sheet for specific product specifications.*

- Designed to hold pressures up to 3500 psig (see table below for specific pressures).
- Durable metal design for added safety
- Easy field upgrades to Mini-Lever actuated valves (special tool required PN: 15000333).
- Adaptable to the 944, 945, 930, 955, NV55, and NOVA valves.
- Use with padlock sizes #7(.187" diameter) through #3(.281" diameter).
- Adaptable for panel mount use (.065"-.125")

Product	Maximum Operating Pressure	Maximum Safety Inlet Pressure in Closed & Locked Position
944M ..... LK	3500 PSIG (240 barg)	3500 PSIG (240 barg)
945M ..... LK	3500 PSIG (240 barg)	3500 PSIG (240 barg)
930M ..... LK	250 PSIG (17.2 barg)	250 PSIG (17.2 barg)
955M ..... LK	250 PSIG (17.2 barg)	250 PSIG (17.2 barg)
NV55M ..... LK	250 PSIG (17.2 barg)	250 PSIG (17.2 barg)
NOVAM ..... LK	3500 PSIG (240 barg)	3500 PSIG (240 barg)



# LockOut-TagOut

## Dimensional Drawing

Valve Type	Dimension A	Dimension B
930M	3.57 (90.7)	2.55 (64.7)
944M	3.80 (96.5)	2.78 (70.6)
945M	3.57 (90.7)	2.55 (64.8)
955M	3.72 (94.5)	2.70 (68.6)
NV55M	3.57 (90.7)	2.55 (64.8)
NOVAM	3.45 (87.6)	2.43 (61.7)

## Ordering Information

Refer to each individual basic series valve type literature sheet for proper ordering information.

### LockOut-TagOut

#### BASIC SERIES

944M ..... LK  
 945M ..... LK  
 930M ..... LK  
 955M ..... LK  
 NV55M .....LK  
 NOVAM ....LK

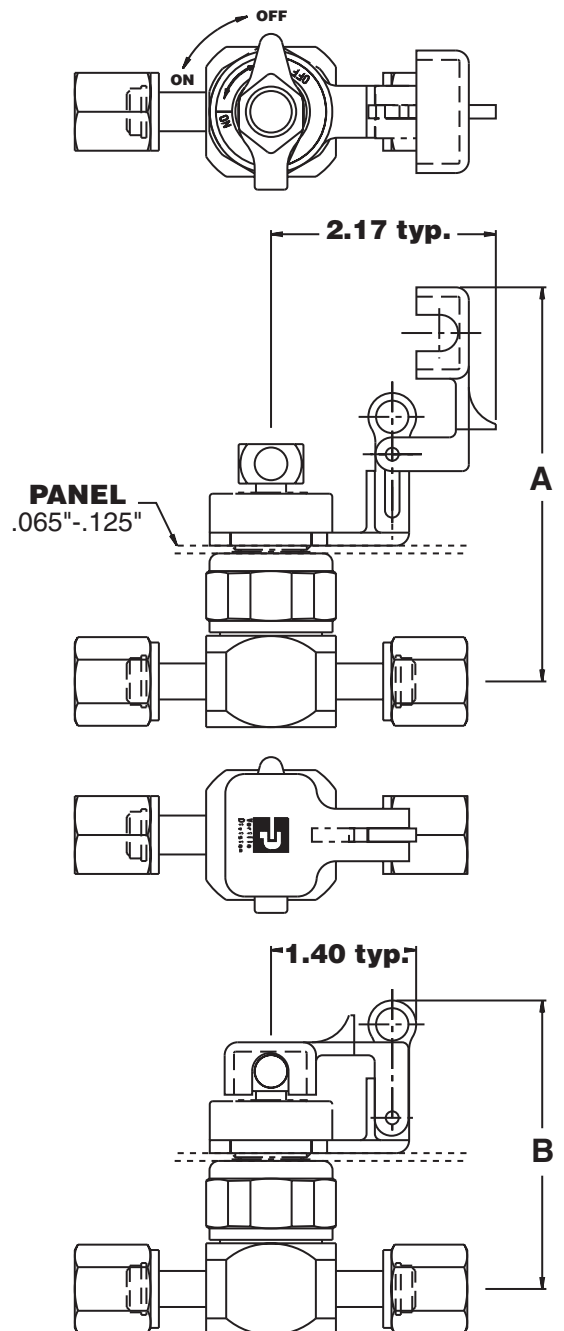



Parker Hannifin Corporation's Veriflo Division presents the VAC100 vacuum generator which has been designed to be used in conjunction with purge systems.



### features

- ▶ The vacuum generated is a function of the pressure of the purge gas which flows through the generator.
- ▶ Vacuum generator will improve the effectiveness of cycle purging.
- ▶ The VAC100 will increase the efficiency of the dilution process in purge systems, when the vacuum port of the VAC100 is connected to the outlet of the vent valve.

### materials of construction

#### Wetted

Body .....	316L Stainless Steel
Venturi .....	316L Stainless Steel
Nozzle .....	316L Stainless Steel

### operating conditions

Temperature .....	-40°F to 200°F (-40°C to 95°C)
-------------------	-----------------------------------

### standard configurations

1/8" NPT (2 male NPT and 1 female NPT)
1/4" FS male and/or female fittings

### approximate weight

2.0 oz (.03 kg)

# VAC100

## Dimensional Drawing

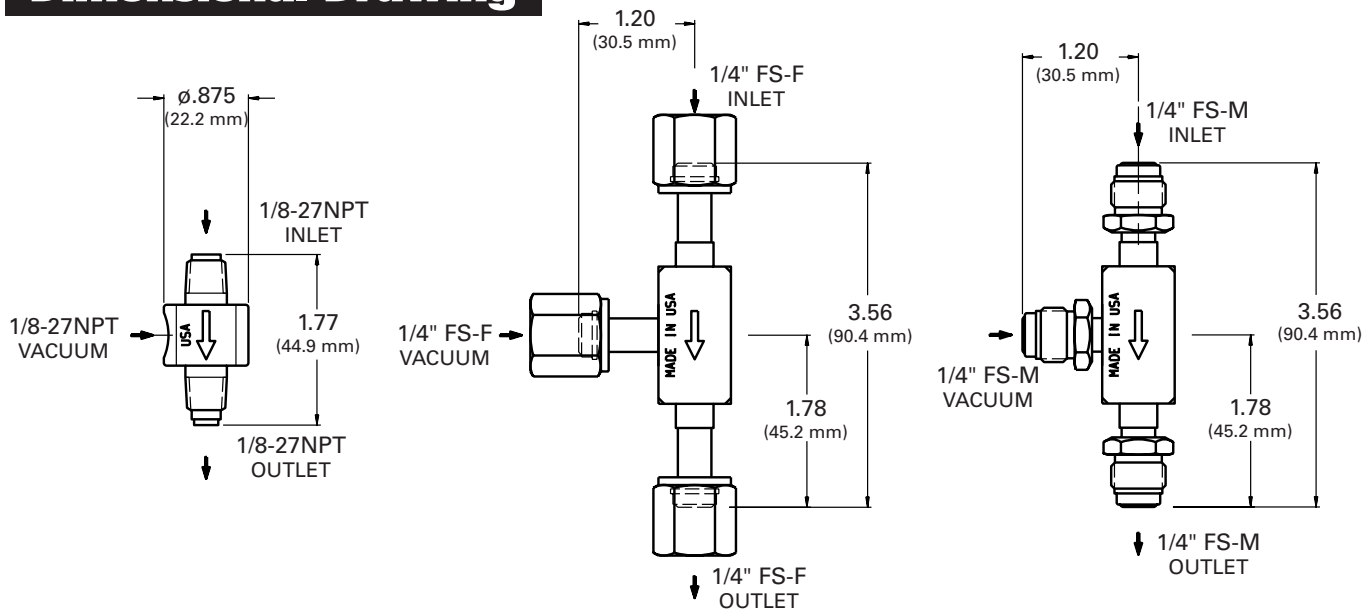

## Flow Curves

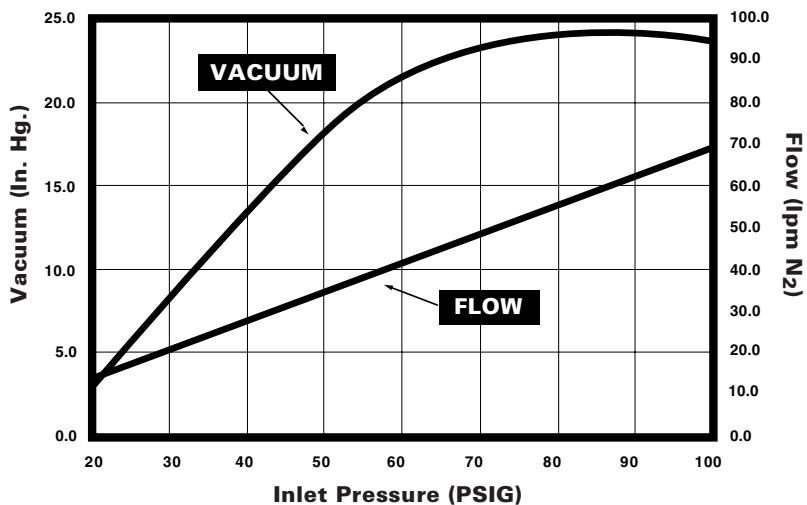

## TYPICAL VALUES

Pressure	Flow	Vacuum
40 psig (2.7 barg)	30 SLPM	13 in. Hg. (330 mm Hg)
60 psig (4.1 barg)	40 SLPM	21 in. Hg. (533 mm Hg)
80 psig (5.5 barg)	55 SLPM	24 in. Hg. (635 mm Hg)

## Ordering Information

**VAC100 S FSF**

**BASIC SERIES** | VAC100

**MATERIAL** | S = 316L Stainless Steel

### CONNECTIONS

2 = 1/8" NPTM  
 FSF = 1/4" Face Seal Female  
 FSM = 1/4" Face Seal Male



**Parker Hannifin Corporation**  
 6035 Parkland Blvd.  
 Cleveland, Ohio 44124-4141  
 Telephone: (216) 896-3000  
 Fax: (216) 896-4000  
 www.parker.com

## Parker Hannifin Corporation

### About Parker Hannifin Corporation

Parker Hannifin is a leading global motion-control company dedicated to delivering premier customer service. A Fortune 500 corporation listed on the New York Stock Exchange (PH), our components and systems comprise over 1,400 product lines that control motion in some 1,000 industrial and aerospace markets. Parker is the only manufacturer to offer its customers a choice of hydraulic, pneumatic, and electromechanical motion-control solutions. Our Company has the largest distribution network in its field, with over 7,500 distributors serving nearly 400,000 customers worldwide.

### Parker's Charter

To be a leading worldwide manufacturer of components and systems for the builders and users of durable goods. More specifically, we will design, market and manufacture products controlling motion, flow and pressure. We will achieve profitable growth through premier customer service.

### Product Information

North American customers seeking product information, the location of a nearby distributor, or repair services will receive prompt attention by calling the Parker Product Information Center at our toll-free number: 1-800-C-PARKER (1-800-272-7537). In Europe, call 00800-C-PARKER-H (00800-2727-5374).

**The Aerospace Group** is a leader in the development, design, manufacture and servicing of control systems and components for aerospace and related high-technology markets, while achieving growth through premier customer service.

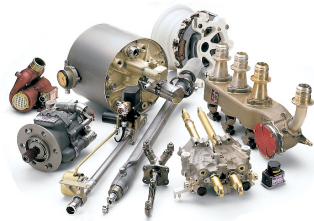

**The Climate & Industrial Controls Group** designs, manufactures and markets system-control and fluid-handling components and systems to refrigeration, air-conditioning and industrial customers worldwide.



**The Fluid Connectors Group** designs, manufactures and markets rigid and flexible connectors, and associated products used in pneumatic and fluid systems.



**The Seal Group** designs, manufactures and distributes industrial and commercial sealing devices and related products by providing superior quality and total customer satisfaction.



**The Hydraulics Group** designs, produces and markets a full spectrum of hydraulic components and systems to builders and users of industrial and mobile machinery and equipment.



**The Filtration Group** designs, manufactures and markets quality filtration and clarification products, providing customers with the best value, quality, technical support, and global availability.



**The Automation Group** is a leading supplier of pneumatic and electromechanical components and systems to automation customers worldwide.



**The Instrumentation Group** is a global leader in the design, manufacture and distribution of high-quality critical flow components for worldwide process instrumentation, ultra-high-purity, medical and analytical applications.







**Parker Hannifin Corporation**  
Veriflo Division  
250 Canal Boulevard  
Richmond, CA 94804-0034  
Telephone 510.235.9590  
Fax 510.232.7396  
Web site: <http://www.veriflo.com>

Catalog: 4505  
LitPN: 25000179  
Revision: A • 10/03

