

Type 1490 Low Pressure Diaphragm Gauge

The Ashcroft® Type 1490 low pressure diaphragm gauge is designed to measure pressure from 10 in. H₂O to 15 psi, both positive and negative pressures. This gauge uses a very sensitive diaphragm capsule to measure low pressure and vacuum. The gauge is specifically designed for use whenever the pressure medium is a gas that is not corrosive to beryllium copper, brass, polysulfone and RTV silicone. Typical applications are, but not limited to, vacuum pumps, gas leak detectors, air compressors, air filters, gas burners, gas measurement, vacuum ovens, suction regulators and respirators.

Type 1495 Low Pressure Receiver Gauge

The Ashcroft Type 1495 receiver gauge uses a diaphragm capsule as its sensing element rather than a bourdon tube. The sensitivity of the diaphragm promotes smooth pointer motion that makes minor pressure changes easy to read.

The Type 1495 receiver gauge is the ideal product where the standard Grade A accuracy (2-1-2%) or the optional Grade 1A (1%) accuracy and smaller dial sizes are specified. The long pointer, smooth-operating sensing element, easily removable window and re-zero adjustment screw make specification and installation of this receiver gauge quick and easy.

1490 and 1495 Standard Specifications

Type:	1490 – low pressure diaphragm gauge 1495 – diaphragm receiver gauge 3 to 15 psi	Accuracy:	ASME Grade A 2-1-2%
Dial Size:	2½" and 3½"	Zero Adjust:	Recalibration screw on dial
Case Material:	Glass-filled polysulfone	Proof Pressure:	150% of range
Window:	Polycarbonate quarter-turn bayonet style mounting	Burst Pressure:	Up to 5 psi range – 50 psi, 5 psi to 15 psi range – 100 psi
Pointer:	Black aluminum	Operating Temperature:	–20 to 180°F
Dial:	White aluminum with black markings	Storage Temperature:	–45 to 185°F
Movement:	Brass	Table A	
Sensing Element:	Beryllium copper diaphragm	1490/1495 Options	
Wetted Materials:	Beryllium copper, brass, polysulfone and RTV silicone	Code	Description
Sockets:	Brass	XAK	Autoclavable at 275°F for 30 minutes. The unit can be autoclaved five times. Polysulfone window will be supplied.
Connection:	½ and ¼ NPT lower and back. Hose barb ⅛, ⅜ or ¼ lower and back connect	XAN	1% optional accuracy
Ranges:	10 in. H ₂ O through 15 psi including vacuum and compound. See chart for 1490 and 1495 Ranges.	XDA	Dial marking
		XNH	Stainless steel tag
		XNN	Paper tag
		XTU	Throttle plug
		XUC ⁽²⁾	U-clamp

Warning: All gauge components should be selected considering the medium and ambient operating conditions to prevent misapplication. Improper application can be detrimental to the gauge, and can cause failure and possible personal injury or property damage.

How To Order

Dial Size		Type		Wetted Material		Connection Size & Type		Connection Location	
Code	Description	Code	Description	Code	Description	Code	Description	Code	Description
25	2½"	1490	Low Pressure Diaphragm Gauge	A	Beryllium Copper	01	1/8 NPT	L	Lower
					Brass Socket	02	1/4 NPT	B	Center Back
35	3½"	1495	Diaphragm Receiver Gauge		Polysulfone	HD	⅛" Hose Barb ⁽²⁾	T	Top
					RTV Silicone	HE	⅜" Hose Barb ⁽²⁾	D	3 O'Clock
						HF	¼" Hose Barb ⁽²⁾	E	9 O'Clock

EXAMPLES: 25 1490A 02L 10 IW XNH

⁽²⁾ U-clamp furnished when hose barb specified.

1490 Low Pressure Diaphragm Gauge

Standard Ranges

Pressure	Figure Intervals	Minor Graduation
0/10 in. H ₂ O	1	0.1
0/15 in. H ₂ O	5	0.2
0/30 in. H ₂ O	5	0.5
0/60 in. H ₂ O	10	1
0/100 in. H ₂ O	10	1
0/160 in. H ₂ O	20	2
0/200 in. H ₂ O	20	2
0/300 in. H ₂ O	50	5
0/10 oz./in. ²	1	0.1
0/15 oz./in. ²	5	0.2
0/30 oz./in. ²	5	0.5
0/60 oz./in. ²	10	1
0/100 oz./in. ²	10	1
0/160 oz./in. ²	20	2
0/250 oz./in. ²	50	5
0/3 psi	0.5	0.05
0/5 psi	1	0.1
0/10 psi	1	0.1
0/15 psi	5	0.2
Vacuum		
15/0 in. H ₂ O	5	0.2
30/0 in. H ₂ O	5	0.5
60/0 in. H ₂ O	10	1
100/0 in. H ₂ O	10	1
200/0 in. H ₂ O	20	2
15/0 oz./in. ²	5	0.2
30/0 oz./in. ²	5	0.5
60/0 oz./in. ²	10	1
100/0 oz./in. ²	10	1

Compound

-30/30 in. H ₂ O	10	1
-30/30 oz./in. ²	10	1
-10/10 in. H ₂ O	2	0.2

Standard Metric Ranges

Pressure	Figure Intervals	Minor Graduation
0/60 cm. H ₂ O	10	1
0/2.5 kPa	0.5	0.05
0/4 kPa	1	0.1
0/10 kPa	1	0.1
0/16 kPa	2	0.2
0/25 kPa	5	0.5
0/40 kPa	10	1
0/100 kPa	10	1

Vacuum

2.5/0 kPa	0.5	0.05
4/0 kPa	1	0.1
10/0 kPa	1	0.1
16/0 kPa	2	0.2
25/0 kPa	5	0.5
40/0 kPa	10	1
100/0 kPa	10	1

Compound

-10/60 cm H ₂ O	10	1
-10/80 cm H ₂ O	10	1
-20/40 cm H ₂ O	10	1
-10/100 cm H ₂ O	10	1
-10/120 cm H ₂ O	20	2

Dual Scale

Range	Graduations				
	Inner Scale		Outer Scale		
Inner Scale	Outer Scale	Figure	Minor	Figure	Minor
0/9 oz./in. ²	0/15 in. H ₂ O	1	0.2	5	0.2
0/20 oz./in. ²	0/35 in. H ₂ O	5	0.5	5	0.5
0/35 oz./in. ²	0/60 in. H ₂ O	5	0.5	10	1
0/60 oz./in. ²	0/100 in. H ₂ O	10	1	10	1

Other ranges available on request. Consult factory

1495 Diaphragm Receiver Gauge

Standard Ranges

Pressure	Figure Intervals	Minor Graduation
0-100%	10	1
0-10 square root	1	0.1
0-10 sq rt/0-100 Linear ¹		

1. This dial is standard and will be supplied unless otherwise ordered. Figure/minor intervals same as single scale.



Ranges		Optional Features	
Code	Description	Code	Description
10 IW	0 to 10 in. H ₂ O See chart above for entire list of ranges	XNH	Stainless Steel Tag See Table A for entire list of options

DIMENSIONS

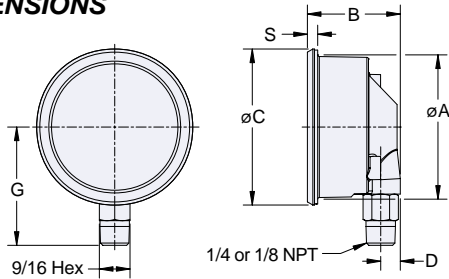

Size	øA	B	øC	D	G	S
25	2 ¹⁹ / ₃₂ (66)	1 ²³ / ₃₂ (44)	2 ⁷ / ₈ (73)	3 ⁸ / ₁₀ (10)	2 ³ / ₁₆ (55)	1 ³ / ₆₄ (5)
35	3 ² / ₃₂ (93)	1 ¹ / ₁₆ (43)	3 ³ / ₃₂ (101)	3 ⁸ / ₁₀ (10)	2 ²³ / ₃₂ (69)	1 ³ / ₆₄ (5)

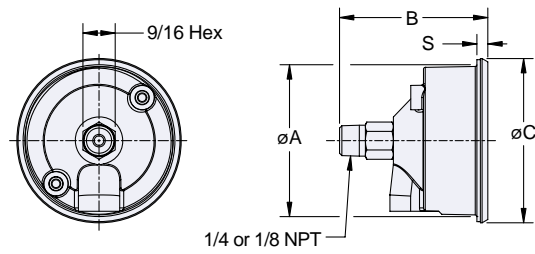

Size	øA	B	øC	S
25	2 ¹⁹ / ₃₂ (66)	2 ¹⁹ / ₃₂ (66)	2 ⁷ / ₈ (73)	1 ³ / ₆₄ (5)
35	3 ² / ₃₂ (93)	2 ⁹ / ₁₆ (65)	3 ³ / ₃₂ (101)	1 ³ / ₆₄ (5)

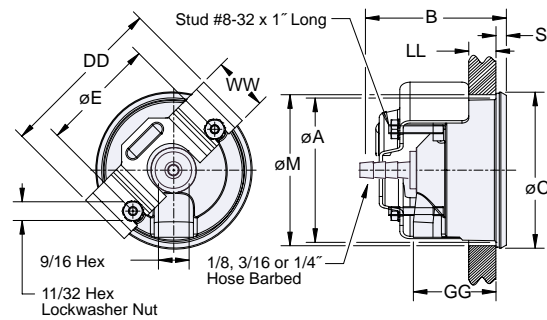
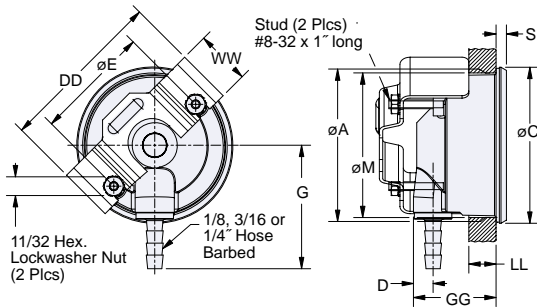

Size	øA	øC	D	øE	G			øM	S	DD	GG	LL MAX	WW
					1/8	3/16	1/4						
25	2 ¹⁹ / ₃₂ (66)	2 ⁷ / ₈ (73)	3 ⁸ / ₁₀ (54)	2 ¹ / ₈ (54)	1 ³ / ₄ (44)	2 ¹ / ₈ (54)	2 ⁹ / ₃₂ (54)	2 ² / ₃₂ (67)	1 ³ / ₆₄ (5)	3 ¹ / ₁₆ (78)	1 ¹⁹ / ₃₂ (40)	1/2 (13)	1 (25)
35	3 ² / ₃₂ (93)	3 ³ / ₃₂ (101)	3 ⁸ / ₁₀ (67)	3 ³ / ₁₆ (67)	2 ⁵ / ₁₆ (59)	2 ² / ₃₂ (81)	2 ¹ / ₃₂ (54)	3 ³ / ₄ (95)	1 ³ / ₆₄ (5)	4 ¹ / ₈ (105)	1 ¹⁷ / ₃₂ (39)	1/2 (13)	1 (25)

Size	øA	B			øC	øE	øM	S	DD	GG	LL MAX	WW
		1/8	3/16	1/4								
25	2 ¹⁹ / ₃₂ (66)	2 ³ / ₁₆ (55)	2 ¹⁷ / ₃₂ (64)	2 ¹¹ / ₁₆ (68)	2 ⁷ / ₈ (73)	2 ¹ / ₈ (54)	2 ² / ₃₂ (67)	1 ³ / ₆₄ (5)	3 ¹ / ₁₆ (78)	1 ¹⁹ / ₃₂ (40)	1/2 (13)	1 (25)
35	3 ² / ₃₂ (93)	2 ¹ / ₈ (54)	2 ¹ / ₂ (63)	2 ² / ₃₂ (67)	3 ³ / ₃₂ (101)	3 ³ / ₁₆ (81)	3 ³ / ₄ (95)	1 ³ / ₆₄ (5)	4 ¹ / ₈ (105)	1 ¹⁷ / ₃₂ (39)	1/2 (13)	1 (25)

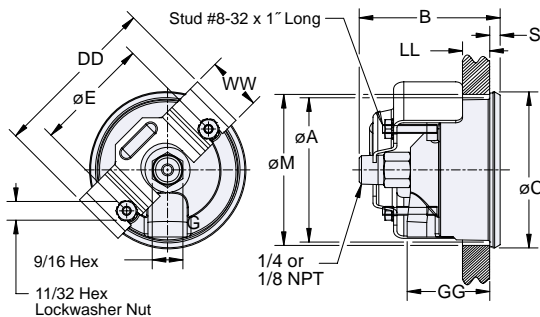

U-clamp Option

Size	øA	B	øC	øE	øM	S	DD	GG	LL MAX	WW
25	2 ¹⁹ / ₃₂ (66)	2 ¹⁹ / ₃₂ (66)	2 ⁷ / ₈ (73)	2 ¹ / ₈ (54)	2 ² / ₃₂ (67)	1 ³ / ₆₄ (5)	3 ¹ / ₁₆ (78)	1 ¹⁹ / ₃₂ (40)	1/2 (13)	1 (25)
35	3 ² / ₃₂ (93)	2 ⁹ / ₁₆ (65)	3 ³ / ₃₂ (101)	3 ³ / ₁₆ (81)	3 ³ / ₄ (95)	1 ³ / ₆₄ (5)	4 ¹ / ₈ (105)	1 ¹⁷ / ₃₂ (39)	1/2 (13)	1 (25)

U.S. Headquarters

Stratford, Connecticut
 250 E. Main Street
 Stratford, CT 06614-5145
 Tel: (203) 378-8281
 Fax: (203) 385-0499

U.S. Sales Offices

Chicago, Illinois
 400 W. Lake Street
 Suite 318
 Roselle, IL 60172-3537
 Tel: (630) 980-9030
 Fax: (630) 980-9440

Houston, Texas
 3838 North Sam Houston
 Parkway East, Suite 120
 Houston, TX 77032
 Tel: (281) 590-1092
 Fax: (281) 590-7100

Mobile, Alabama
 851 South Bellline Hwy.
 Suite 402, 4th Floor
 Mobile, AL 36606
 Tel: (334) 473-1692
 Fax: (334) 473-1782

Hartford, Connecticut
 1501 East Main Street
 Meriden, CT 06450-2860
 Tel: (203) 235-0450
 Fax: (203) 235-0593

Los Angeles, California
 3931 MacArthur Blvd.
 Suite 202
 Newport Beach, CA 92660
 Tel: (949) 852-8948
 Fax: (949) 852-8971

Specifications subject to change without notice.
 Subject to standard terms and conditions of sale.
 © instrument Division, Dresser Equipment Group, Inc.
 1P3/97 20MCP 2/2000



a Halliburton company



Type 1490 Low Pressure Diaphragm Gauge

Type 1495 Diaphragm Receiver Gauge



ASHCROFT
Beryllium Copper diaphragm
Brass socket

ISO 9001
REGISTERED FIRM

DRESSER INSTRUMENT

a Halliburton company