

DETAIL DATA ON AVAILABLE CAPILLARIES AND THERMOWELLS

CAPILLARIES – OPTIONAL TUBE LENGTHS

Standard model 604TU, 646TUE and 6900TU series temperature switches are furnished with a 5' capillary. Optional 10', 15', and 25' capillaries are available. Order as listed below:

- 10' capillary: When ordering add **-7001** to model number
- 15' capillary: When ordering add **-7002** to model number
- 25' capillary: When ordering add **-7003** to model number

HOW TO ORDER:

1. Specify standard model number of temperature switch desired.
2. Add the above number that specifies capillary length to end of standard number.

EXAMPLE: To order 646TUE1 with 15' capillary, specify 646TUE1-7002

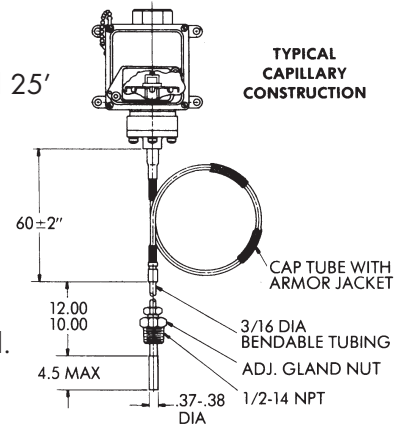

THERMOWELLS

Readily available convenience items for use with Temperature Switch Models.

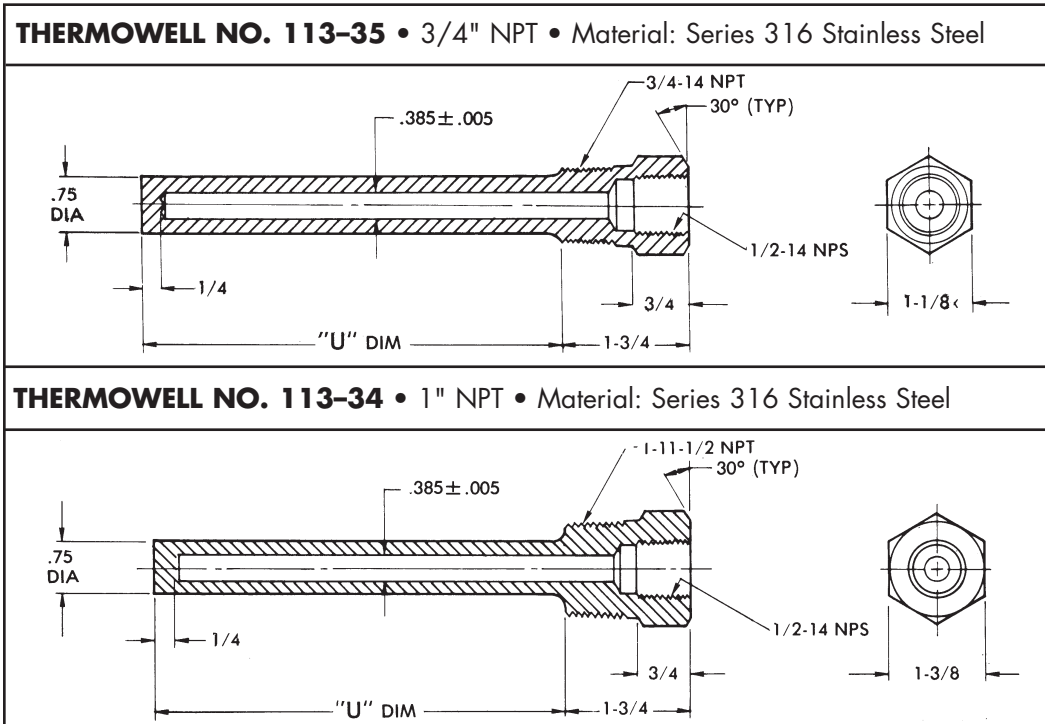

HOW TO ORDER:

Specify thermowell part number as a separate item.

| "U" Dim. | Part Number | Part Number |
|----------|-------------|-------------|
| 4 1/2" | 113-35-1 | 113-34-1 |
| 7 1/2" | 113-35-2 | 113-34-2 |
| 10 1/2" | 113-35-3 | 113-34-3 |
| 13 1/2" | 113-35-4 | 113-34-4 |