















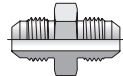
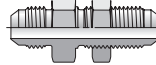
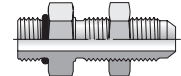
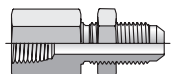
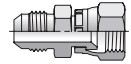
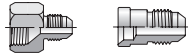

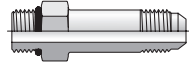
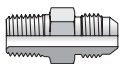

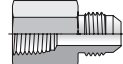





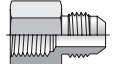
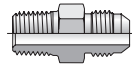

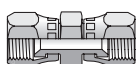
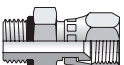

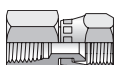

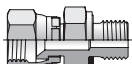

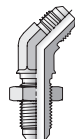
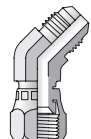
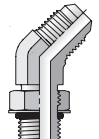
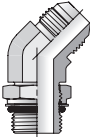
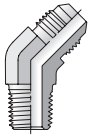

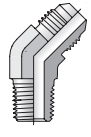
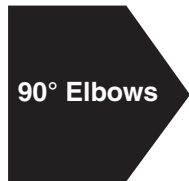
# ***Triple-Lok<sup>®</sup> and Triple-Lok<sup>®</sup> 2 37° Flare Tube Fittings***

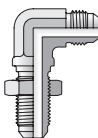
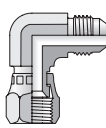
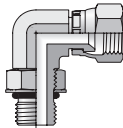
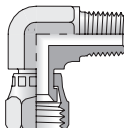
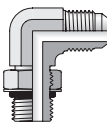
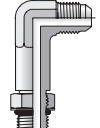
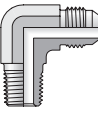
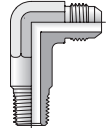
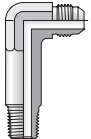
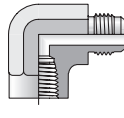
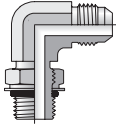
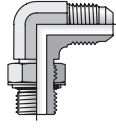
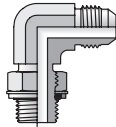
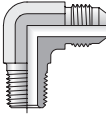

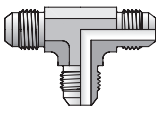
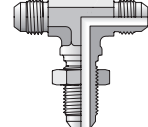
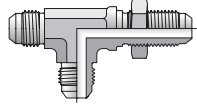
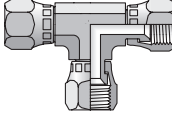
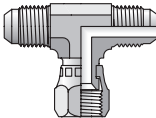
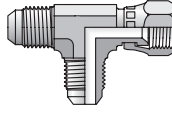
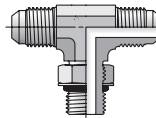
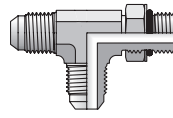
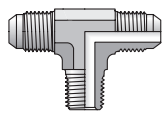
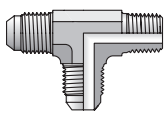
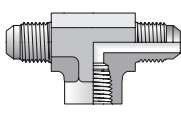
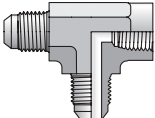
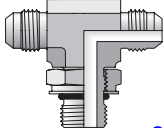
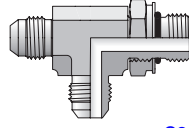
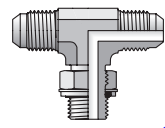
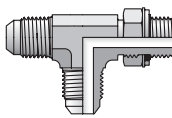
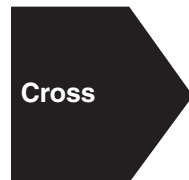
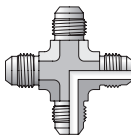



***The Fitting Authority***

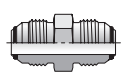

	<b>BTX</b> Nut  C14	<b>TX and TX Metric</b> Sleeve  C14	<b>WLN</b> Bulkhead Locknut  C15	<b>SBR</b> Braze Ring  C15	
		<b>HTX</b> Union  C15	<b>LHTX</b> Large Hex Union  C15	<b>WTX</b> Bulkhead Union  C16	<b>WF50X</b> SAE-ORB / 37° Bulkhead  C16
<b>WGTX</b> NPTF / 37° Bulkhead  C17		<b>HXH6</b> Extender and Expander  C17	<b>TRTX / TRTXN</b> Reducer  C18	<b>F50X</b> SAE-ORB / 37° Flare  C19	<b>FF50X</b> SAE-ORB / 37° – Long  C19
<b>FTX</b> NPTF / 37° Flare  C20	<b>FFTX</b> NPTF / 37° Flare – Long  C20	<b>GTX</b> NPTF / 37° Flare  C20	<b>F870MX</b> ISO 6149 / 37° Flare  C21	<b>F82EDMX</b> Metric-ED / 37° Flare  C21	<b>F80MX</b> Metric-ORR / 37° Flare  C21
<b>F42EDMX</b> BSPP-ED / 37° Flare  C21	<b>F40MX</b> BSPP-ORR / 37° Flare  C22	<b>G4MX</b> BSPP / 37° Flare  C22	<b>F3MX</b> BSPT / 37° Flare  C22		<b>HX6</b> 37° Swivel Union  C22
<b>F650X</b> SAE-ORB / 37° Swivel  C23	<b>F6X</b> NPTF / 37° Swivel  C23	<b>G6X</b> NPTF / 37° Swivel  C23	<b>F6870MX</b> ISO-6149 / 37° Swivel  C23		<b>F680MX</b> Metric-ORR / 37° Swivel  C24
<b>F642EDMX</b> BSPP-ED / 37° Swivel  C24	<b>F63MX</b> BSPT / 37° Swivel  C24		<b>WNTX</b> Bulkhead Union  C25	<b>V6X</b> 37° Swivel Elbow  C25	<b>V50X</b> SAE-ORB / 37° Flare  C25
<b>V870MX</b> ISO-6149 / 37° Flare  C25	<b>VTX</b> NPTF / 37° Flare  C26		<b>V40MX</b> BSPP-ORR / 37° Flare  C26	<b>V3MX</b> BSPT / 37° Flare  C26	

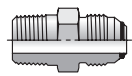
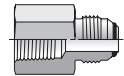
<p><b>WETX</b> Bulkhead Union</p>  <p>C27</p>	<p><b>C6X</b> 37° Swivel Elbow</p>  <p>C27</p>	<p><b>AOEX6</b> SAE-ORB / 37° Swivel</p>  <p>C27</p>	<p><b>X6EF</b> NPTF / 37° Swivel</p>  <p>C28</p>	<p><b>C50X</b> SAE-ORB / 37° Flare</p>  <p>C28</p>	<p><b>CC50X</b> SAE-ORB / 37° – Long</p>  <p>C28</p>
<p><b>CTX</b> NPTF / 37° Flare</p>  <p>C29</p>	<p><b>CCTX</b> NPTF / 37° Flare – Long</p>  <p>C29</p>	<p><b>CCCTX</b> NPTF / 37° – Extra Long</p>  <p>C29</p>	<p><b>DTX</b> NPTF / 37° Flare</p>  <p>C30</p>	<p><b>C870MX</b> ISO-6149 / 37° Flare</p>  <p>C30</p>	<p><b>C80MX</b> Metric-ORR / 37° Flare</p>  <p>C30</p>
<p><b>C40MX</b> BSPP-ORR / 37° Flare</p>  <p>C31</p>	<p><b>C3MX</b> BSPT / 37° Flare</p>  <p>C31</p>	<p><b>Tees</b></p> 	<p><b>JTX</b> Union Tee</p>  <p>C31</p>	<p><b>WJTX</b> Bulkhead Branch Tee</p>  <p>C32</p>	<p><b>WJJTX</b> Bulkhead Run Tee</p>  <p>C32</p>
<p><b>JX6</b> 37° Swivel Union Tee</p>  <p>C33</p>	<p><b>S6X</b> 37° Swivel Branch Tee</p>  <p>C33</p>	<p><b>R6X</b> 37° Swivel Run Tee</p>  <p>C33</p>	<p><b>S50X</b> SAE-ORB Branch Tee</p>  <p>C34</p>	<p><b>R50X</b> SAE-ORB Run Tee</p>  <p>C34</p>	<p><b>STX</b> NPTF Branch Tee</p>  <p>C35</p>
<p><b>RTX</b> NPTF Run Tee</p>  <p>C35</p>	<p><b>OTX</b> NPTF Branch Tee</p>  <p>C35</p>	<p><b>MTX</b> NPTF Run Tee</p>  <p>C35</p>	<p><b>S870MX</b> ISO 6149 Branch Tee</p>  <p>C36</p>	<p><b>R870MX</b> ISO 6149 Run Tee</p>  <p>C36</p>	<p><b>S40MX</b> BSPP-ORR Branch Tee</p>  <p>C36</p>
<p><b>R40MX</b> BSPP-ORR Run Tee</p>  <p>C36</p>	<p><b>Cross</b></p> 	<p><b>KTX</b> Union Cross</p>  <p>C37</p>	<p><b>Plug and Cap</b></p> 	<p><b>PNTX</b> 37° Plug</p>  <p>C37</p>	<p><b>FNTX</b> 37° Cap</p>  <p>C37</p>
<p><b>T22X</b> Mountie Cap</p>  <p>C37</p>					

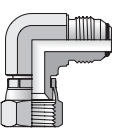
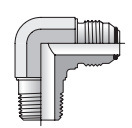
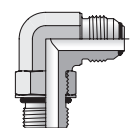
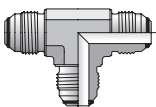
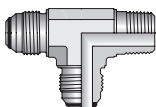
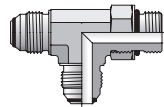
### Triple-Lok® 2 Soft Seal Flare Tube Fittings

 <p><b>Straights</b></p>	<p><b>HTXO</b> Union</p>  <p style="text-align: right; color: blue;">C38</p>	<p><b>F5OXO</b> SAE-ORB / 37° Flare</p>  <p style="text-align: right; color: blue;">C38</p>	<p><b>FTXO</b> NPTF / 37° Flare</p>  <p style="text-align: right; color: blue;">C38</p>	<p><b>GTXO</b> NPTF / 37° Flare</p>  <p style="text-align: right; color: blue;">C38</p>
	<p><b>ETXO</b> Union Elbow</p>  <p style="text-align: right; color: blue;">C39</p>	<p><b>C6XO</b> 37° Swivel Elbow</p>  <p style="text-align: right; color: blue;">C39</p>	<p><b>CTXO</b> NPTF / 37° Flare</p>  <p style="text-align: right; color: blue;">C39</p>	<p><b>C5OXO</b> SAE-ORB / 37° Flare</p>  <p style="text-align: right; color: blue;">C39</p>
	<p><b>JTXO</b> Union Tee</p>  <p style="text-align: right; color: blue;">C40</p>	<p><b>RTXO</b> 37° Swivel Run Tee</p>  <p style="text-align: right; color: blue;">C40</p>	<p><b>R5OXO</b> SAE-ORB Run Tee</p>  <p style="text-align: right; color: blue;">C40</p>	

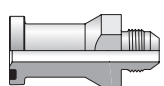
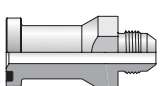
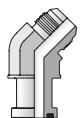
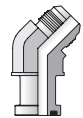

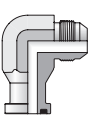
### Flange Adapters (Shown in Section M)

<p><b>SAE Flange Adapters</b></p> 	<p><b>XHQ1</b> Code 61 / 37° Flare</p>  <p style="text-align: right; color: blue;">M10</p>	<p><b>XHQ2</b> Code 62 / 37° Flare</p>  <p style="text-align: right; color: blue;">M10</p>	<p><b>XVQ1</b> Code 61 / 37° Flare</p>  <p style="text-align: right; color: blue;">M28</p>	<p><b>XVQ2</b> Code 62 / 37° Flare</p>  <p style="text-align: right; color: blue;">M28</p>	<p><b>XEQ1</b> Code 61 / 37° Flare</p>  <p style="text-align: right; color: blue;">M29</p>
<p><b>XEQ2</b> Code 62 / 37° Flare</p>  <p style="text-align: right; color: blue;">M29</p>					

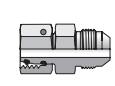
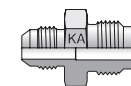
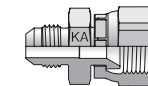
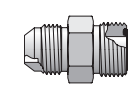
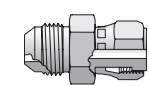
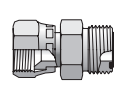
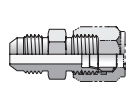
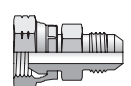
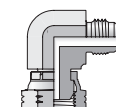
**Conversion Adapters** (Shown in Sections K and L)

	<b>XHU86</b> Metric Swivel (EO) / 37°  L5	<b>XHMKA</b> Komatsu 30° / 37° Flare  K6	<b>XHMKA6</b> Komatsu 30° Swivel / 37°  K6	<b>XHLO</b> 37° Flare / ORFS  L3	<b>XHL6</b> 37° Flare / ORFS Swivel  L3
	<b>LOHX6</b> ORFS / 37° Swivel  L3	<b>XHBU</b> 37° Flare / Flareless  L4	<b>XHMK46</b> 37° Flare / BSPP Swivel  L5	<b>XEMK46</b> 37° Flare / BSPP Swivel  L5	

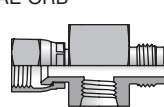
**Diagnostic and Orifice Fittings** (Shown in Section N)

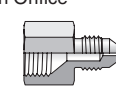
	<b>XHX6G5TP</b> 37° Flare / 37° Swivel / SAE-ORB  N5		<b>XHX7</b> 37° Flare / 37° Female with Orifice  N11



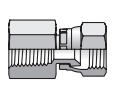
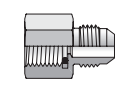

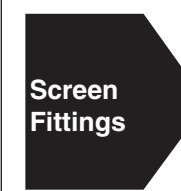
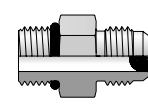

**Gauge Fittings** (Shown in Section N)

	<b>G6X</b> NPT Gauge / 37° Swivel  N7	<b>G4MXSMO</b> BSPP Gauge / 37° Flare  N6

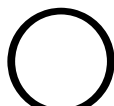
**Screen Fittings** (Shown in Section N)

	Screen Fittings  N12

**O-Rings and Seals** (Shown in Section O)

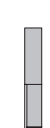
	<b>XO O-Ring</b>  O3	<b>SAE O-Ring</b>  O3	<b>ISO 6149 O-Ring</b>  O4	<b>Metric O-Ring</b>  O4	<b>Metric Retaining Ring</b>  O4
	<b>BSPP O-Ring</b>  O5	<b>BSPP Retaining Ring</b>  O5	<b>EOLastic Seal Ring</b>  O5		

## Triple-Lok Introduction

Parker pioneered the flare fitting concept early in the 20<sup>th</sup> century. The design has since gained worldwide acceptance due to its many inherent features and customer benefits. Today, the 37° flare fitting is the most widely used fitting in the world. Its appeal is in its simplicity, compact design, ease of assembly, reliability (single seal), material availability, adaptability to inch or metric tube, worldwide availability and acceptance. Further helping its acceptance is its widespread use as a hose adapter. As a tube fitting, it is especially suited for thin and medium wall thickness tube. Even though 37° flare fittings are generally considered to be 3000 psi fittings, Triple-Lok's capabilities range from 9000 psi for 1/4" size to 2000 psi for 2" size. Currently, it is used in virtually every application that uses fluid power for motion control.

Parker's Triple-Lok fittings meet the strict requirements of SAE J514 and ISO 8434-2 industry standards. Additionally, they meet many customer and industry-recognized conformance standards and type approvals.

## Design and Construction

The Triple-Lok (37° flare fitting) design is simple. It uses an easily produced flare at the tube end to seal and hold fluid under high pressure. The fitting consists of three pieces: the body, sleeve and nut. The tube end is flared at a 37° angle (74° included angle) and held between the fitting nose (seat) and the sleeve (support) with the nut as shown in Fig. C2, providing a very effective (single) seal between the fitting nose and the tube flare.

The design of Triple-Lok fittings is very efficient. The fitting incorporates the smallest seal area of all fitting types. This seal area, as seen in Fig. C2, is only slightly larger than the fluid flow area. The small seal area results in a compact design, low assembly torque, and a relatively high-pressure capability.

The primary difference between a two-piece flare fitting and the three-piece design is the flare support sleeve. The support sleeve provides several key functions:

1. It provides a clamping surface for the tube flare.
2. It provides a bearing surface for the tube nut. The sleeve isolates the tube from the nut, minimizing the tube twist during assembly, a common problem of 2-piece flare fitting designs.
3. It provides support to the tube flare. The tapered fitting nose tends to "wedge open" the tube flare during assembly. The sleeve helps to resist this expansion, thus eliminating the possibility of tube flare and sleeve jamming inside the nut. This eliminates any waste of applied torque and allows for easy disassembly.
4. It makes the fitting adaptable to metric tube merely by changing its inside diameter (see [Table C2](#)).

Due to the popularity and simplicity of the 37° flare fitting, many manufacturers offer the product. Even though most manufacturers conform to the same dimensional standards, there are significant performance advantages with Parker's Triple-Lok fittings due to Parker's optimized manufacturing methods and commitment to quality.



Fig. C1 – Triple-Lok Fitting Body, Sleeve and Nut

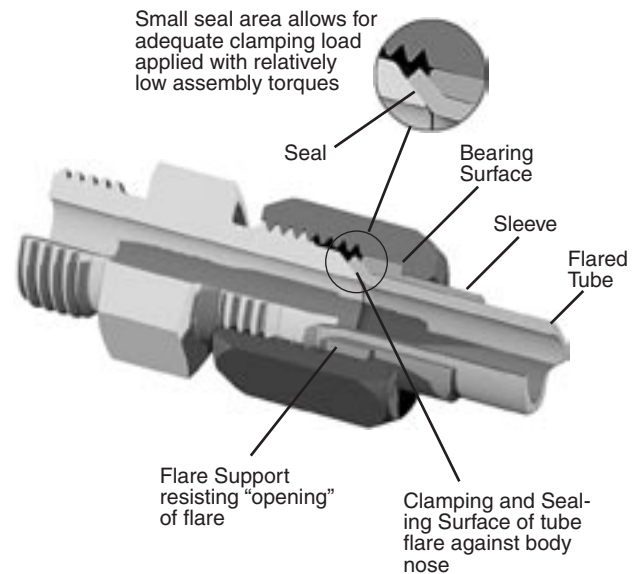

Fig. C2 – Triple-Lok Design and Features

## Materials and Manufacture

Triple-Lok fitting components are manufactured using state-of-the-art equipment and manufacturing technologies to assure construction integrity, optimum strength and toughness, long service life and the highest quality. At the heart of the Triple-Lok product line are the finest raw materials and manufacturing technologies as outlined in [Table C1](#) and discussed below.

**The Triple-Lok Body:** Triple-Lok fittings are manufactured in over 65 configurations. Straight bodies are either cold formed or machined from cold drawn bar stock. The cold forming process ensures consistent dimensional tolerances, improved mechanical properties and better surface finishes. Shaped Triple-Lok fittings are manufactured from a one-piece forged construction. This forged construction eliminates the potential leak path associated with multi-component brazed fittings. Triple-Lok steel forged shapes also feature an optimum combination of hardness and toughness for high-pressure capability, minimal nose collapse (typical of sizes -10 and under) during repeated assembly and long service life, even under severe operating conditions.

**The Triple-Lok Sleeves:** Most steel Triple-Lok flare support sleeves are cold formed and heat treated for an optimum combination of strength and ductility. The largest size sleeves, -20, -24, and -32, are machined from high strength steel. Stainless steel and brass sleeves are machined from cold drawn barstock.

**The Triple-Lok Tube Nuts:** Triple-Lok steel tube nuts are cold formed, except in sizes -20, -24, and -32, which are machined from cold drawn barstock. Cold forming increases the material strength and its fatigue properties, imparting high strength and longer service life to the nuts. Smaller stainless steel nuts are also cold formed while all brass tube nuts are manufactured from cold drawn brass barstock. Most crimp swivel nuts are also cold formed.

**Robust Port Stud:** The adjustable port stud is manufactured with a longer locknut designed to cover the uppermost threads completely. Since the backup washer is never exposed to the upper threads, it cannot be damaged during assembly. During assembly, exposed upper threads, as common with fittings from other fitting manufacturers, can lead to a deformed backup washer that can pinch the o-ring and create an o-ring extrusion gap that has the potential to leak. The longer locknut also provides a greater grip area for the wrench.

**Dual Angle Female Seat:** The seat of the female swivel is manufactured with a dual angle that accepts both the 37° flare and 45° flare fitting (only sizes 4, 5, 8 and 10 45° flare fittings). The dual angle seat also repositions the seal location away from the tip of the male flare nose, preventing the nose from biting into the seat and making it more tolerant to minor nose tip damage.

## How Triple-Lok Fittings Work

Tightening of the nut clamps the tube flare between the body nose (seat) producing a leak tight connection. This clamping on the 37° taper provides a measure of elasticity to the joint helping it to resist loosening under vibration. The clamping force results in a small radial load that tends to deform the fitting nose radially. The resistance of the nose to elastic deformation provides a constant preload (similar to a lockwasher) keeping it tight.

The clamping force provided by the nut resists the opposing force of the fluid under pressure. The joint remains leak tight as long as the clamping force is higher than the opposing pressure load. Properly assembled Triple-Lok fittings with appropriate tube will seal consistently under pressure until tube bursts.

Sealing in Triple-Lok fittings takes place between two smooth metal surfaces, the fitting nose and inside of the tube flare. Therefore, the sealing surfaces have to be smooth, free of any nicks, scratches, spiral tool marks, splits or weld beads. Seamless or welded and drawn fully annealed tube is recommended for Triple-Lok fittings for ease in flaring and bending. Certain types of harder tubes that are not fully annealed may not be suitable for flaring due to the potential for immediate or long-term cracking of the tube flare. For specific tube type and wall thickness recommendations, please see [Table C3](#).

Triple-Lok Fittings	Steel		Stainless Steel		Brass	
	ASTM	Type	ASTM	Type	ASTM	Type
Cold Formed Bodies	A576	C1010/ C1008	—	—	—	—
Forged Bodies	A576	1214/ 1215	A182	316	B124	CA377
Bar Stock Bodies	A108	12L14	A479	316	B16 B453	CA360 CA345
Cold Formed Nuts	A576	C1010/ C1008	A276	316	B121	CA335
Bar Stock Tube Nuts	A108	12L14	A479	316	B16 B453	CA360 CA345
Cold Formed Sleeves	SAE 1020	SAE 1020	—	—	B111	CA443 CA444
Bar Stock Sleeves	A108	C1137	A479	316	B371	CA694

**Table C1 – Standard Material Specifications for Triple-Lok Fittings**

**Note:** On request, Triple-Lok fittings can be furnished in materials other than those shown above.

**Finish:** Zinc with yellow chromate (being changed to zinc chromium 6 free) is used on all standard steel products.

## Assembly and Installation

Please refer to [Section T](#) for the assembly and installation instructions for Triple-Lok fittings.

Dimensions and pressures for reference only, subject to change.

## International Acceptance

The Triple-Lok male flare end is attachable to either inch tube, metric tube or a hose assembly. Parker offers many different port thread options for the various international hydraulic ports available. This is one of the primary reasons for its worldwide acceptance. Parker has traditionally offered a “Metric Triple-Lok” product line directed at the Metric, ISO-6149 and BSPP port users. Rather than carrying a separate catalog section, this range of international fittings has been integrated into the traditional “Triple-Lok” section.

To illustrate the versatility of Triple-Lok, refer to Fig. C3. A single 37° fitting body will accept both inch and metric tube sizes by simply changing the sleeve. Thus, a dedicated line of sleeves is offered for inch and metric tube. The universal tube nut and fitting body is used with either inch or metric tube, thus saving on component costs and making the Triple-Lok fitting more versatile. Also, the 37° body without the nut and sleeve is very popular as a hose adapter.

Study the following example illustrating the options with an SAE –8 (1/2”) Triple-Lok fitting:

1. Fitting with a –8 (1/2”) sleeve and –8 (1/2”) tube nut can connect to a 1/2” o.d. flared tube.
2. Fitting with a 12 mm sleeve and –8 (1/2”) tube nut can connect to 12 mm o.d. flared tube
3. Fitting without a nut and sleeve can be used as a 1/2” hose adapter when connected to a hose swivel.

Table C2 illustrates an even clearer picture of the flexibility of the Triple-Lok 37° system. It shows every “convertible sleeve” connection for the 37° flare design. For example, if 25 mm tube is being used, a –16 (1”) 37° flare fitting together with a 25 mm (TXS25) sleeve and a standard –16 (1”) flare fitting nut would be all the necessary components to connect and seal a 25 mm flared tube assembly.

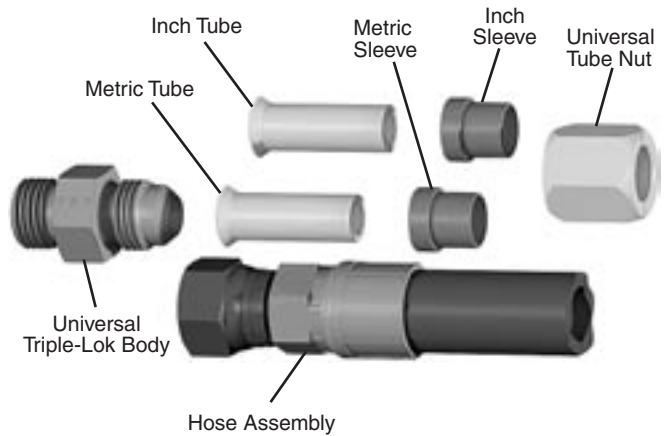

Fig. C3 – Triple-Lok’s Adaptability to Inch Tube, Metric Tube, or Hose Assemblies

FITTING DASH SIZE	TUBE O.D.	METRIC TUBE SLEEVE PART #	NUT PART #
-4	6mm	TXS6	4 BTX-S
-5	8mm	5 TX-S	5 BTX-S
-6	10mm	TXS10	6 BTX-S
-8	12mm	TXS12	8 BTX-S
-10	14mm	TXS14	10 BTX-S
-10	15mm	TXS15	10 BTX-S
-10	16mm	10 TX-S	10 BTX-S
-12	18mm	TXS18	12 BTX-S
-12	20mm	20-12 TX-S	20-12 BTX-S
-14	22mm	TXS22	14 BTX-S
-16	25mm	TXS25	16 BTX-S
-20	28mm	TXS28	20 BTX-S
-20	30mm	TXS30	20 BTX-S
-20	32mm	TXS32	20 BTX-S
-24	35mm	TXS35	24 BTX-S
-24	38mm	24 TX-S	24 BTX-S

Table C2 – Triple-Lok Convertible Sleeve Connections

## Tube Wall Thickness – Inch and Metric

Minimum/Maximum tube wall thickness is based on the pressure holding capacity of the fittings and subject to maximum wall thickness limitations.

FITTING DASH SIZE	WALL THICKNESS – INCH TUBE			WALL THICKNESS – METRIC TUBE		
	O.D. (in.)	Min. (in.)	Max.	O.D. (mm)	Min. (mm)	Max.
-2	1/8	0.010	– 0.035	–	–	–
-3	3/16	0.010	– 0.035	–	–	–
-4	1/4	0.020	– 0.065	6.0	0.5	2.0
-5	5/16	0.020	– 0.065	8.0	0.5	2.0
-6	3/8	0.020	– 0.065	10.0	0.5	2.0
-8	1/2	0.028	– 0.083	12.0	1.0	2.0
-10	5/8	0.035	– 0.095	14.0	1.0	2.5
-10	5/8	0.035	– 0.095	15.0	1.0	2.5
-10	5/8	0.035	– 0.095	16.0	1.0	2.5
-12	3/4	0.035	– 0.109	18.0	1.0	3.0
-12	3/4	0.035	– 0.109	20.0	1.0	3.0
-14	7/8	0.035	– 0.109	22.0	1.0	3.0
-16	1	0.035	– 0.120	25.0	1.0	3.0
-20	1 1/4	0.049	– 0.120	30.0	1.5	3.0
-20	1 1/4	0.049	– 0.120	32.0	1.5	3.0
-24	1 1/2	0.049	– 0.120	38.0	1.5	3.0
-32	2	0.058	– 0.134	50.0	1.5	3.5

Table C3 – Wall Thickness Chart for Inch and Metric Tubing



## Features, Advantages & Benefits

Feature	Advantage	Benefit
Small sealing area	Low assembly torque to achieve sealing.	Ease of assembly.
Metal-to-metal seal	Allows for wide range of operating temperatures and media.	Versatility for different applications.
No minimum wall thickness limitation	Allows for optimum tube selection and lower weight hydraulic package.	Reduces material cost and weight.
Short tube entry	Minimum tube prying required for installation and maintenance.	Easier installation and maintenance.
Adaptable to metric tube	Easily meets customer's needs for inch or metric tube.	Versatility for end customer and for customer standardization efforts.
International standard design	Meets global needs.	Standardization. Global acceptance.
Worldwide availability	Due to the proven design, worldwide customer acceptance, adaptability to metric and inch tube as well as hose adapter, Triple-Lok fittings are readily available throughout the world.	OEM and aftermarket support and parts readily available worldwide.
Used as hose adapter	Adapts directly to hose swivel connection, the most commonly used hose connection in the world. One connector for tube and hose.	Versatility for flexible system requirements. Minimizes connector proliferation.
Available in steel, stainless steel and brass	Wide selection.	Optimum match to customer's needs.
Longer adjustable locknut	Backup washer is never exposed to upper threads, preventing damage during assembly.	Insures proper assembly to prevent leaks.
	Increased grip area for wrench.	Easier installation
Dual angle female seat	Accepts both 37° and 45° flare fittings (size 4, 5, 8 and 10, 45° flare only).	Versatility for end customer. Minimize inventory
	Repositions seal location away from the tip of the nose, preventing nose from biting into mating seat and making it more tolerant to minor nose tip damage.	Higher quality assembly and longer service life.
Forged shapes	No potential leak path and longer fatigue life.	Long service life.
	Compact design.	Used in tighter spaces without redesigning.
Heat treated forgings	Optimum balance of strength and toughness. Minimum nose collapse. Balanced strength and shock resistance.	Flow restrictions are minimal, repeated assembly possible, no leakage. Higher working pressure and longer service life.
Cold formed tube nuts and sleeves	Stronger than machined nuts.	Longer service life. More robust product.
Widest range of tube O.D. sizes available in a hydraulic fitting	All standard and several non-traditional sizes are available including: 1/8", 3/16", 5/16", 7/8", 2" and 2-1/2" tube O.D. sizes. Also, 16 different metric tube sizes are adaptable to Triple-Lok.	Additional flexibility for hydraulic systems.
Broad line of configurations and port ends available	Meets global needs for OEM and MRO applications.	Standardization and cost control. Less components. Eliminates conversion adapters.

Table C4 – Features, Advantages and Benefits

## Triple-Lok 2 Introduction

Parker's Triple-Lok 2 combines the versatility of stainless steel Triple-Lok with the added advantage of an elastomeric seal. Triple-Lok 2 incorporates a replaceable seal in the nose of the flare, which is positioned so that leak-free connections are made without compromising the strength of the fitting. Triple-Lok 2 shape fittings with SAE straight thread adjustable studs also feature Parker's new patent-pending design, providing easier assembly and improved reliability. Triple-Lok 2 can be used in any industrial application where corrosion resistance and leak-free connections are essential. Triple-Lok 2 is a direct interchange for any industrial 37° flare fitting, allowing current 37° flare fitting users to take advantage of Triple-Lok 2 without changing hoses or tubes.



Fig. C4 – Triple-Lok 2 Fitting Body, Sleeve and Nut

## Design and Construction

The Triple-Lok 2 design incorporates an elastomeric seal in the nose of the 37° flare. The O-ring is positioned so that elastomeric sealing occurs with the mating tube regardless of tube wall thickness. It uses an easily produced flare at the tube end to seal and hold fluid under high pressure. The fitting consists of three pieces: the body (with O-ring), sleeve and nut (Fig. C4). The tube end is flared at a 37° angle (74° included angle) and held between the fitting nose (seat) and the sleeve (support) with the nut as shown in Fig. C5, providing a very effective elastomeric seal between the fitting nose and the tube flare.

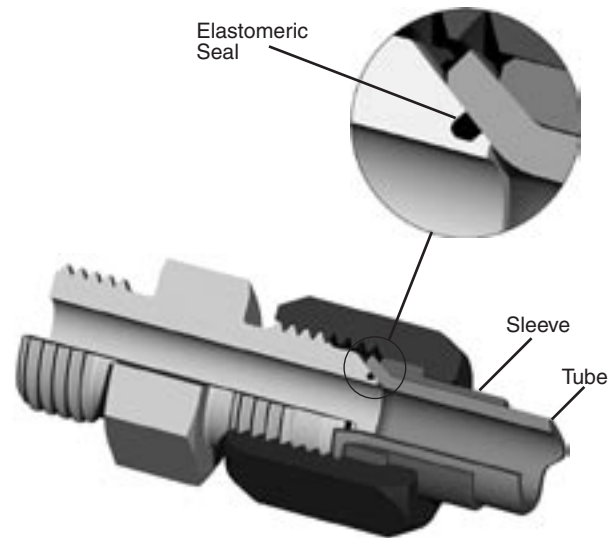

Fig. C5 – Triple-Lok 2 Design and Features

## Materials and Manufacture

Triple-Lok 2 fitting components are manufactured using state-of-the-art equipment and manufacturing technologies to assure construction integrity, optimum strength and toughness, long service life and the highest quality. At the heart of the Triple-Lok 2 product line are the finest raw materials and manufacturing technologies as outlined in Table C5 and discussed below.

**The Triple-Lok 2 Body:** Triple-Lok 2 fittings are manufactured in the most popular stainless steel sizes and configurations. Straight bodies are machined from cold drawn bar stock. Shaped Triple-Lok 2 fittings are manufactured from a one-piece forged construction. This forged construction eliminates the potential leak path associated with multi-component brazed fittings.

**The Triple-Lok Sleeves:** Stainless steel sleeves are machined from cold drawn barstock.

**The Triple-Lok Tube Nuts:** The tube nuts are either cold formed or machined from cold drawn barstock. The cold forming process increases the material strength and its fatigue properties, imparting high strength and longer service life to the nuts.

## How Triple-Lok 2 Fittings Work

Tightening of the nut clamps the tube flare between the body nose and O-ring, producing a leak tight connection. This

Triple-Lok 2 Fittings	Stainless Steel	
	ASTM	Type
Forged Bodies	A182	316
Bar Stock Bodies	A479	316
Cold Formed Nuts	A276	316
Bar Stock Tube Nuts	A479	316
Bar Stock Sleeves	A479	316

**Table C5 – Standard Material Specifications for Triple-Lok 2 Fittings**  
**Finish:** Stainless steel fittings are passivated.

clamping on the 37° taper provides a measure of elasticity to the joint helping it to resist loosening under vibration. The clamping force results in a small radial load that tends to deform the fitting nose radially. The resistance of the nose to elastic deformation provides a constant preload (similar to a lockwasher) keeping it tight.

The clamping force provided by the nut resists the opposing force of the fluid under pressure. The joint remains leak tight as long as the clamping force is higher than the opposing pressure load. Properly assembled Triple-Lok 2 fittings with appropriate tube will seal consistently under pressure until tube bursts.

Sealing in Triple-Lok 2 fittings takes place as the o-ring is compressed between the fitting body and the inside of the tube flare. The O-ring should be inspected at each disassembly and replaced when necessary. Seamless or welded and drawn fully annealed tube is recommended for Triple-Lok 2 fittings for ease in flaring and bending. Certain types of harder tubes that are not fully annealed may not be suitable for flaring due to the potential for immediate or long-term cracking of the tube flare. For specific tube type and wall thickness recommendations, please see [Table C7](#).

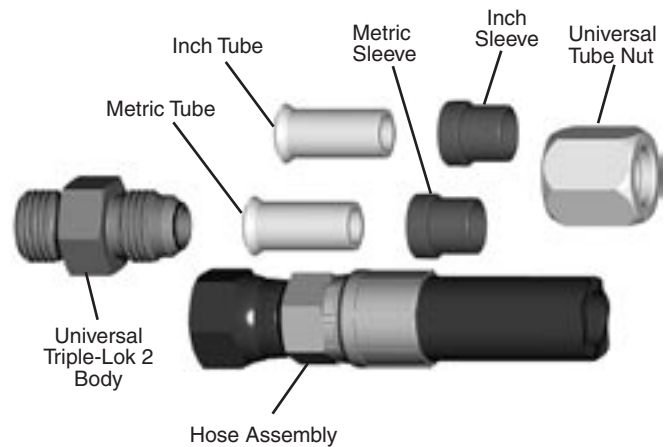

Fig. C6 – Triple-Lok 2's Adaptability to Inch Tube, Metric Tube, or Hose Assemblies

## Assembly and Installation

Assembly and installation instructions are the same as Triple-Lok 2 and located in [Section T](#).

## International Acceptance

To illustrate the versatility of Triple-Lok 2, refer to Fig. C6. A single 37° fitting body will accept both inch and metric tube sizes by simply changing the sleeve. Thus, a dedicated line of sleeves is offered for inch and metric tube. The universal tube nut and fitting body is used with either inch or metric tube, thus saving on component costs and making the Triple-Lok 2 fitting more versatile. Also, the fitting body without the nut and sleeve is very popular as a hose adapter.

Table C6 illustrates an even clearer picture of the flexibility of the Triple-Lok 2 Soft Seal 37° system. It shows every "convertible sleeve" connection for the 37° flare design. For example, if 25mm tube is being used, a -16 (1") Triple-Lok 2 37° Soft Seal flare fitting together with a 25mm (TXSS25) sleeve and a standard -16 (1") flare fitting nut would be all the necessary components to connect and seal a 25mm flared tube assembly.

## Tube Wall Thickness – Inch and Metric

Minimum/Maximum tube wall thickness is based on the pressure holding capacity of the fittings and subject to maximum wall thickness limitations.

FITTING DASH SIZE	TUBE O.D.	METRIC TUBE SLEEVE PART #	NUT PART #
-4	6mm	TXSS6	4BTX-SS
-5	8mm	5 TX-SS	5BTX-SS
-6	10mm	TXSS10	6BTX-SS
-8	12mm	TXSS12	8BTX-SS
-10	14mm	TXSS14	10BTX-SS
-10	15mm	TXSS15	10BTX-SS
-10	16mm	10 TX-SS	10BTX-SS
-12	18mm	TXSS18	12BTX-SS
-12	20mm	20-12 TX-SS	20-12BTX-SS
-14	22mm	TXSS22	14BTX-SS
-16	25mm	TXSS25	16BTX-SS
-20	28mm	TXSS28	20BTX-SS
-20	30mm	TXSS30	20BTX-SS
-20	32mm	TXSS32	20BTX-SS
-24	35mm	TXSS35	24BTX-SS
-24	38mm	24 TX-SS	24BTX-SS

Table C6 – Triple-Lok 2 Convertible Sleeve Connections

FITTING DASH SIZE	WALL THICKNESS – INCH TUBE			WALL THICKNESS – METRIC TUBE		
	O.D. (in.)	WALL THICKNESS		O.D. (mm)	WALL THICKNESS	
		Min.	(in.) Max.		Min.	(mm) Max.
-2	1/8	0.010	– 0.035	–	–	–
-3	3/16	0.010	– 0.035	–	–	–
-4	1/4	0.020	– 0.065	6.0	0.5	– 2.0
-5	5/16	0.020	– 0.065	8.0	0.5	– 2.0
-6	3/8	0.020	– 0.065	10.0	0.5	– 2.0
-8	1/2	0.028	– 0.083	12.0	1.0	– 2.0
-10	5/8	0.035	– 0.095	14.0	1.0	– 2.5
-10	5/8	0.035	– 0.095	15.0	1.0	– 2.5
-10	5/8	0.035	– 0.095	16.0	1.0	– 2.5
-12	3/4	0.035	– 0.109	18.0	1.0	– 3.0
-12	3/4	0.035	– 0.109	20.0	1.0	– 3.0
-14	7/8	0.035	– 0.109	22.0	1.0	– 3.0
-16	1	0.035	– 0.120	25.0	1.0	– 3.0
-20	1 1/4	0.049	– 0.120	30.0	1.5	– 3.0
-20	1 1/4	0.049	– 0.120	32.0	1.5	– 3.0
-24	1 1/2	0.049	– 0.120	38.0	1.5	– 3.0
-32	2	0.058	– 0.134	50.0	1.5	– 3.5

Table C7 – Wall Thickness Chart for Inch and Metric Tubing

## Features, Advantages & Benefits

Feature	Advantage	Benefit
Elastomeric seal	Tolerant of surface imperfections	Provides leak-free connection
Replaceable O-ring seal	Provides easy maintenance	Reduced down time and maintenance costs
Standard size O-rings in -10 thru -32	O-rings are readily available	Reduced down time and maintenance costs
Increased flow diameters versus other soft seal flare fittings	Less pressure drop and higher flow rates through fittings	More efficient hydraulic systems
Longer adjustable locknut	Backup washer is never exposed to upper threads, preventing damage during assembly.	Insures proper assembly to prevent leaks.
	Increased grip area for wrench.	Easier installation
Dual angle female seat	Accepts both 37° and 45° flare fittings (size 4, 5, 8 and 10 45° flare only).	Versatility for end customer. Minimize inventory
	Repositions seal location away from the tip of the nose, preventing nose from biting into mating seat and making it more tolerant to minor nose tip damage.	Higher quality assembly and longer service life.
Adaptable to metric tube	Easily meets customer's needs for inch or metric tube	Versatility for end customer and for customer standardization efforts
Used as hose adapter	Adapts directly to hose swivel connection, the most commonly used hose connection in the world. One connector for tube and hose.	Versatility for flexible system requirements. Minimizes connector proliferation.
Forged shapes	No potential leak path and longer fatigue life with compact design	Longer service life
Assembles using standard Triple-Lok assembly torque	No changes to assembly procedures	No additional training

Table C8 – Features, Advantages and Benefits

# Triple-Lok 37° Flared Tube Ends

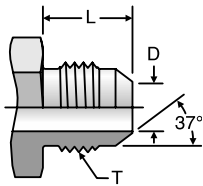

Triple-Lok Male Flare Tube End

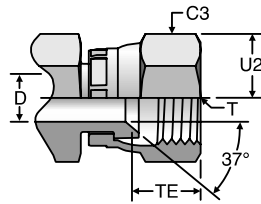

Triple-Lok Swivel

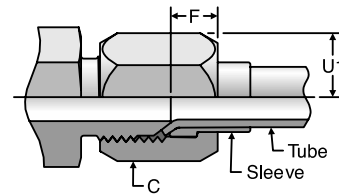

Triple-Lok Tube End Assembly

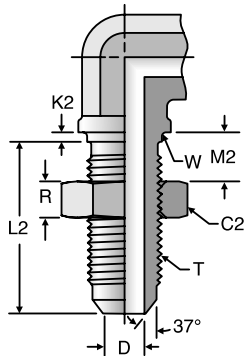

Triple-Lok Shape Bulkhead

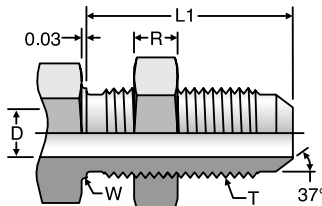

Triple-Lok Straight Bulkhead

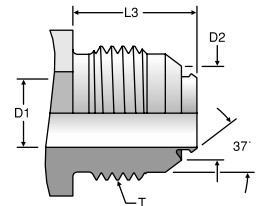

Triple-Lok 2 Male Flare Tube End

SAE Dash Size	Tube O.D.		T	C	C2	C3	D	D1	L	L3	F	TE	K2	L1	L2	R	W <sup>1)</sup>	Max Bulkhead Thickness		Min. Flare Dia.												
																		Thread	Tube Nut Hex		Bulkhead Locknut Hex	Swivel Nut Hex	Max Drill	Male Turn Back	Assembly Allowance		Bulkhead				Straights	Shapes
																									Tube Nut	Swivel Nut	Pilot Length - Shapes	Length - Straights	Length - Shapes	Locknut Thickness		
2	1/8	—	5/16-24	3/8	9/16	7/16	—	0.062	—	0.45	—	0.19	0.31	0.094	1.11	0.92	0.22	0.313	0.38	0.25	—											
3	3/16	—	3/8-24	7/16	5/8	1/2	—	0.125	—	0.48	—	0.25	0.33	0.094	1.11	0.92	0.22	0.375	0.38	0.25	—											
4	1/4	6	7/16-20	9/16	11/16	9/16	14	0.172	0.156	0.55	0.56	0.19	0.34	0.094	1.20	1.02	0.28	0.438	0.38	0.25	0.254											
5	5/16	8	1/2-20	5/8	3/4	5/8	16	0.234	0.217	0.55	0.56	0.30	0.38	0.094	1.20	1.02	0.28	0.500	0.38	0.25	0.314											
6	3/8	10	9/16-18	11/16	13/16	11/16	17	0.297	0.263	0.56	0.57	0.28	0.38	0.094	1.28	1.09	0.27	0.563	0.44	0.35	0.359											
8	1/2	12	3/4-16	7/8	1	7/8	22	0.391	0.391	0.66	0.66	0.31	0.42	0.125	1.44	1.25	0.31	0.750	0.44	0.35	0.510											
10	5/8	14 15 16	7/8-14	1	1 1/8	1	27	0.484	0.446	0.76	0.81	0.38	0.50	0.125	1.58	1.39	0.36	0.875	0.44	0.35	0.610											
12	3/4	18 20	1 1/16-12	1 1/4	1 3/8	1 1/4	32	0.609	0.585	0.86	0.91	0.36	0.56	0.125	1.75	1.56	0.41	1.063	0.44	0.35	0.753											
14	7/8	22	1 3/16-12	1 3/8	1 1/2	1 3/8	36	0.718	0.680	0.89	0.95	0.38	0.58	0.125	1.75	1.56	0.41	1.188	0.44	0.35	0.849											
16	1	25	1 5/16-12	1 1/2	1 5/8	1 1/2	38	0.844	0.769	0.91	0.99	0.34	0.59	0.125	1.75	1.56	0.41	1.313	0.44	0.35	0.940											
20	1 1/4	28 30 32	1 5/8-12	2	1 7/8	2	50	1.078	1.020	0.96	1.03	0.34	0.63	0.125	1.80	1.61	0.41	1.625	0.44	0.35	1.198											
24	1 1/2	35 38	1 7/8-12	2 1/4	2 1/8	2 1/4	60	1.312	1.230	1.08	1.16	0.50	0.73	0.125	1.81	1.62	0.41	1.875	0.31	0.22	1.416											
32	2	—	2 1/2-12	2 7/8	2 3/4	2 7/8	—	1.781	1.736	1.33	1.40	0.55	0.94	0.125	2.09	1.91	0.41	2.500	0.35	0.25	1.994											
40 <sup>2)</sup>	2 1/2	—	3-12	3-3/8	—	—	—	2.281	—	—	—	0.55	—	—	—	—	—	—	—	—	—											

1) Recommended clearance hole = W + 0.015.

2) Not a standard SAE J514 size.

Dimensions and pressures for reference only, subject to change.



# BTX

Nut  
37° Flare

SAE 070110  
HPD Base # 06B

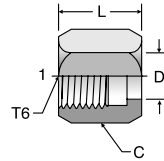

TUBE FITTING PART #	END SIZE		T6 UN/UNF-2B	C HEX (in.)	D (in.)	L (in.)	STANDARD FROM STOCK		
	(in.)	(mm)					-S	-SS	-B
2 BTX	1/8	—	5/16-24	3/8	0.18	0.55	•	•	•
3 BTX	3/16	—	3/8-24	7/16	0.24	0.61	•	•	•
4 BTX	1/4	6	7/16-20	9/16	0.31	0.62	•	•	•
5 BTX	5/16	8	1/2-20	5/8	0.38	0.68	•	•	•
6 BTX	3/8	10	9/16-18	11/16	0.44	0.73	•	•	•
8 BTX	1/2	12	3/4-16	7/8	0.57	0.85	•	•	•
10 BTX	5/8	14, 15, 16	7/8-14	1	0.70	0.98	•	•	•
12 BTX	3/4	18	1 1/16-12	1 1/4	0.84	1.03	•	•	•
20-12 BTX	—	20	1 1/16-12	32.0 mm	21.9 mm	26.0 mm	•	•	•
14 BTX	7/8	—	1 3/16-12	1 3/8	0.96	1.09	•	•	•
16 BTX	1	25	1 5/16-12	1 1/2	1.09	1.13	•	•	•
20 BTX	1 1/4	28, 30, 32	1 5/8-12	2	1.35	1.23	•	•	•
24 BTX	1 1/2	35, 38	1 7/8-12	2 1/4	1.62	1.42	•	•	•
32 BTX	2	42, 50	2 1/2-12	2 7/8	2.17	1.75	•	•	•

# TX (inch)

Sleeve  
37° Flare

SAE 070115  
HPD Base # 06S

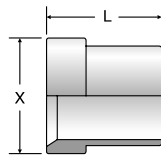

TUBE FITTING PART #	END SIZE (in.)	L (in.)	X (in.)	STANDARD FROM STOCK		
				-S	-SS	-B
2 TX	1/8	0.34	0.27	•	•	•
3 TX	3/16	0.34	0.33	•	•	•
4 TX	1/4	0.41	0.38	•	•	•
5 TX	5/16	0.44	0.45	•	•	•
6 TX	3/8	0.50	0.50	•	•	•
8 TX	1/2	0.56	0.68	•	•	•
10 TX	5/8	0.66	0.80	•	•	•
12 TX	3/4	0.69	0.97	•	•	•
14 TX	7/8	0.75	1.10	•	•	•
16 TX	1	0.78	1.22	•	•	•
20 TX	1 1/4	0.91	1.53	•	•	•
24 TX	1 1/2	1.13	1.78	•	•	•
32 TX	2	1.19	2.41	•	•	•

# TX (metric)

Sleeve  
37° Flare

SAE 070115

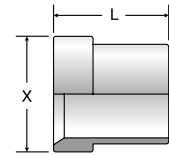

TUBE FITTING PART #	See Note	END SIZE (mm)	FITTING DASH SIZE	L (mm)	X (mm)	STANDARD FROM STOCK		
						-S	-SS	-B
TXS6	3	6	-4	10.4	9.6	•	•	•
5 TX	1	8	-5	11.2	11.4	•	•	•
TXS10	3	10	-6	12.7	12.7	•	•	•
TXS12	3	12	-8	14.2	17.3	•	•	•
TXS14	3	14	-10	16.8	20.3	•	•	•
TXS15	3	15	-10	16.8	20.3	•	•	•
10 TX	1	16	-10	16.8	20.3	•	•	•
TXS18	3	18	-12	17.3	24.6	•	•	•
20-12 TX	2	20	-12	17.3	24.6	•	•	•
TXS22	3	22	-14	19.0	27.8	•	•	•
TXS25	3	25	-16	19.8	31.0	•	•	•
TXS28	3	28	-20	23.1	38.9	•	•	•
TXS30	3	30	-20	23.1	38.9	•	•	•
TXS32	3	32	-20	23.1	38.9	•	•	•
TXS35	3	35	-24	28.4	45.2	•	•	•
24 TX	1	38	-24	28.4	45.2	•	•	•

1. Inch sleeve for use with metric tubing.
2. Use with 20-12 BTX.
3. The part numbers above are for steel. Use "SS" in place of "S" for ordering stainless steel. Example: TXSS12

Dimensions and pressures for reference only, subject to change.



### WLN

Bulkhead Locknut

SAE 080118 and 070118  
HPD Base # 53-XN

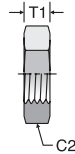

TUBE FITTING PART #	TUBE O.D. (in.)	C2 HEX (in.)	T1 (in.)	STANDARD FROM STOCK		
				-S	-SS	-B
3 WLN	3/16	5/8	0.22	•	•	
4 WLN	1/4	11/16	0.28	•	•	•
5 WLN	5/16	3/4	0.28	•		•
6 WLN	3/8	13/16	0.27	•	•	•
8 WLN	1/2	1	0.31	•	•	•
10 WLN	5/8	1 1/8	0.36	•	•	•
12 WLN	3/4	1 3/8	0.41	•	•	•
14 WLN	7/8	1 1/2	0.41	•		
16 WLN	1	1 5/8	0.41	•	•	
20 WLN	1 1/4	1 7/8	0.41	•	•	
24 WLN	1 1/2	2 1/8	0.41	•	•	
32 WLN	2	2 3/4	0.41	•	•	

### SBR

Braze Ring

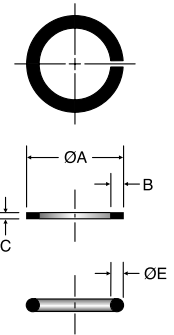

TUBE FITTING PART #	TUBE O.D. (in.)	A DIA. (in.)	B (in.)	C (in.)	E (in.)	STANDARD FROM STOCK		
						-S	-SS	-B
4SBR	1/4	0.260			0.05	•	•	
6SBR	3/8	0.390	0.07	0.03		•	•	
8SBR	1/2	0.515	0.07	0.03		•	•	
10SBR	5/8	0.640	0.07	0.03		•	•	
12SBR	3/4	0.765	0.08	0.04		•	•	
14SBR	7/8	0.890			0.06			
16SBR	1	1.015	0.08	0.04		•	•	
20SBR	1 1/4	1.265	0.08	0.04		•	•	
24SBR	1 1/2	1.515	0.08	0.04		•	•	
32SBR	2	2.015			0.09	•	•	

### HTX

Union  
37° Flare / 37° Flare

SAE 070101  
HPD Base # 0303

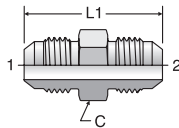

TUBE FITTING PART #	END SIZE		C HEX (in.)	L1 (in.)	STANDARD Dynamic Pressure (x 1,000 PSI)		
	1 (in.)	2 (in.)			-S	-SS	-B
2 HTX	1/8	1/8	7/16	1.17	7.5	9.0	3.3
3 HTX	3/16	3/16	7/16	1.23	7.5	9.0	3.3
4 HTX	1/4	1/4	1/2	1.38	7.5	9.0	3.3
4-2 HTX	1/4	1/8	1/2	1.27		9.0	
4-3 HTX	1/4	3/16	1/2	1.30		9.0	
5 HTX	5/16	5/16	9/16	1.38	6.0	7.2	3.3
5-4 HTX	5/16	1/4	9/16	1.38		7.2	
6 HTX	3/8	3/8	5/8	1.41	6.0	7.2	3.3
6-4 HTX	3/8	1/4	5/8	1.41	6.0	7.2	
6-5 HTX	3/8	5/16	5/8	1.41		7.2	
8 HTX	1/2	1/2	13/16	1.62	6.0	7.2	3.3
8-4 HTX	1/2	1/4	13/16	1.52	6.0	7.2	
8-6 HTX	1/2	3/8	13/16	1.52	6.0	7.2	
10 HTX	5/8	5/8	15/16	1.88	5.0	6.0	3.3
10-8 HTX	5/8	1/2	15/16	1.78	5.0	6.0	
12 HTX	3/4	3/4	1 1/8	2.16	5.0	6.0	3.3
12-8 HTX	3/4	1/2	1 1/8	1.95	5.0	6.0	
12-10 HTX	3/4	5/8	1 1/8	2.05	5.0	6.0	
14 HTX	7/8	7/8	1 1/4	2.22	5.0	6.0	2.6
16 HTX	1	1	1 3/8	2.25	4.0	4.8	2.6
16-12 HTX	1	3/4	1 3/8	2.20	4.0	4.8	
20 HTX	1 1/4	1 1/4	1 11/16	2.44	4.0	4.8	
24 HTX	1 1/2	1 1/2	2	2.75	3.0	3.6	
24-10 HTX	1 1/2	5/8	2	2.42			
24-12 HTX	1 1/2	3/4	2	2.53		3.6	
24-16 HTX	1 1/2	1	2	2.58		3.6	
32 HTX	2	2	2 5/8	3.41	2.0	2.4	
32-24 HTX	2	1 1/2	2 5/8	2.81		2.4	

### LHTX

Large Hex Union  
37° Flare / 37° Flare

SAE 070119  
HPD Base # 03L3

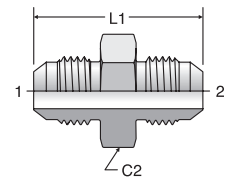

TUBE FITTING PART #	END SIZE		C2 HEX (in.)	L1 (in.)	STANDARD Dynamic Pressure (x 1,000 PSI)		
	1 (in.)	2 (in.)			-S	-SS	-B
4 LHTX	1/4	1/4	11/16	1.38	7.5	9.0	3.3
4-3 LHTX	1/4	3/16	11/16	1.30		9.0	
5 LHTX	5/16	5/16	3/4	1.38	6.0		
6 LHTX	3/8	3/8	13/16	1.41	6.0	7.2	3.3
6-4 LHTX	3/8	1/4	13/16	1.41		7.2	
8 LHTX	1/2	1/2	1	1.62	6.0	7.2	3.3
8-4 LHTX	1/2	1/4	1	1.52		7.2	
8-6 LHTX	1/2	3/8	1	1.52		7.2	
10 LHTX	5/8	5/8	1 1/8	1.88	5.0	6.0	
12 LHTX	3/4	3/4	1 3/8	2.16	5.0	6.0	
12-8 LHTX	3/4	1/2	1 3/8	1.95		6.0	
16 LHTX	1	1	1 5/8	2.25	4.0	4.8	
32 LHTX	2	2	2 3/4	3.41		2.4	

Dimensions and pressures for reference only, subject to change.



### WTX

Bulkhead Union  
37° Flare / 37° Flare

SAE 070601  
HPD Base # 0353  
WTX-WLN – Body with locknut  
(See [page C14](#) for WLN)

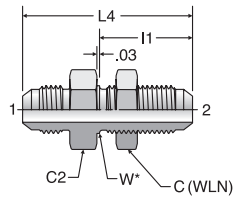

W\* – Bulkhead pilot dia.  
recommended clearance hole  
+.015 over W dia.

TUBE FITTING PART #	END SIZE		C HEX (in.)	C2 HEX (in.)	I1 (in.)	L4 (in.)	W DIA (in.)	MAX BULKHEAD WALL THICKNESS (in.)	STANDARD Dynamic Pressure (x 1,000 PSI)		
	1 & 2 (in.)								-S	-SS	-B
3 WTX	3/16	5/8	5/8	5/8	1.11	1.91	0.38	0.38	7.5		
4 WTX	1/4	11/16	11/16	11/16	1.20	2.08	0.44	0.33	7.5	9.0	3.3
5 WTX	5/16	3/4	3/4	3/4	1.20	2.08	0.50	0.33	6.0		3.3
6 WTX	3/8	13/16	13/16	13/16	1.28	2.19	0.56	0.42	6.0	7.2	3.3
8 WTX	1/2	1	1	1	1.44	2.44	0.75	0.44	6.0	7.2	3.3
10 WTX	5/8	1 1/8	1 1/8	1 1/8	1.58	2.75	0.88	0.43	5.0	6.0	3.3
12 WTX	3/4	1 3/8	1 3/8	1 3/8	1.75	3.09	1.06	0.44	5.0	6.0	3.3
14 WTX	7/8	1 1/2	1 1/2	1 1/2	1.75	3.13	1.19	0.41	5.0		
16 WTX	1	1 5/8	1 5/8	1 5/8	1.75	3.14	1.31	0.39	4.0	4.8	
20 WTX	1 1/4	1 7/8	1 7/8	1 7/8	1.80	3.31	1.63	0.40	4.0	4.8	
24 WTX	1 1/2	2 1/8	2 1/8	2 1/8	1.81	3.52	1.88	0.28	3.0	3.6	
32 WTX	2	2 3/4	2 3/4	2 3/4	2.09	4.20	2.50	0.28	2.0	2.4	

### WF5OX

ORB Bulkhead Connector  
37° Flare / ORB

HPD Base # 0355  
WF5OX-WLN – Body with locknut  
(See [page C15](#) for WLN)

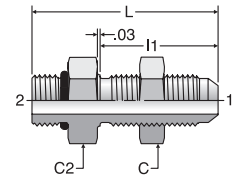

TUBE FITTING PART #	END SIZE		C HEX (in.)	C2 HEX (in.)	I1 (in.)	L (in.)	MAX BULKHEAD WALL THICKNESS (in.)	STANDARD Dynamic Pressure (x 1,000 PSI)		
	1 (in.)	2 UN/UNF-2A						-S	-SS	-B
4 WF5OX	1/4	7/16-20	11/16	11/16	1.20	1.84	0.33	7.5		
6 WF5OX	3/8	9/16-18	13/16	13/16	1.28	2.02	0.42	6.0		
8 WF5OX	1/2	3/4-16	1	1	1.44	2.19	0.44	6.0		
10 WF5OX	5/8	7/8-14	1 1/8	1 1/8	1.58	2.47	0.43	5.0		
12 WF5OX	3/4	1 1/16-12	1 3/8	1 3/8	1.75	2.79	0.44	5.0		
16 WF5OX	1	1 5/16-12	1 5/8	1 5/8	1.75	2.90	0.39	4.5		

### WFTX

Male Bulkhead Connector  
37° Flare / NPTF

HPD Base # 0153  
WFTX-WLN – Body with locknut  
(See [page C15](#) for WLN)

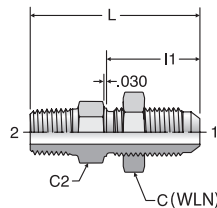

TUBE FITTING PART #	END SIZE		C HEX (in.)	C2 HEX (in.)	I1 (in.)	L (in.)	MAX BULKHEAD WALL THICKNESS (in.)	STANDARD Dynamic Pressure (x 1,000 PSI)		
	1 (in.)	2 NPTF						-S	-SS	-B
4 WFTX	1/4	1/8-27	11/16	11/16	1.20	1.88	0.33	6.0	6.0	
4-4 WFTX	1/4	1/4-18	11/16	11/16	1.20	2.07	0.33	6.0	6.0	
6 WFTX	3/8	1/4-18	13/16	13/16	1.28	2.15	0.42	6.0	6.0	
6-6 WFTX	3/8	3/8-18	3/4	13/16	1.28	2.16	0.42	6.0	6.0	
6-8 WFTX	3/8	1/2-14	7/8	13/16	1.28	2.41	0.42	6.0	6.0	
8 WFTX	1/2	3/8-18	1	1	1.44	2.31	0.44	6.0	6.0	
8-8 WFTX	1/2	1/2-14	1	1	1.44	2.56	0.44	6.0	6.0	
10 WFTX	5/8	1/2-14	1 1/8	1 1/8	1.58	2.71	0.43	5.0	5.0	
12 WFTX	3/4	3/4-14	1 3/8	1 3/8	1.75	2.95	0.44	5.0	5.0	
16 WFTX	1	1-11 1/2	1 5/8	1 5/8	1.75	3.14	0.39	4.5	4.5	

Dimensions and pressures for reference only, subject to change.



# WGTX

Female Bulkhead Connector  
37° Flare / NPTF

HPD Base # 0253  
WGTX-WLN – Body with locknut  
(See [page C15](#) for WLN)

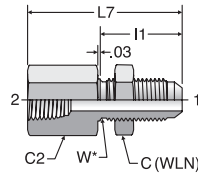

W\* – Bulkhead pilot dia.  
recommended clearance hole  
+.015 over W dia.

TUBE FITTING PART #	END SIZE		C HEX (in.)	C2 HEX (in.)	I1 (in.)	L7 (in.)	W DIA (in.)	MAX BULKHEAD WALL THICKNESS (in.)	STANDARD Dynamic Pressure (x 1,000 PSI)		
	1 (in.)	2 NPTF							-S	-SS	-B
	4 WGTX	1/4									
4-4 WGTX	1/4	1/4-18	11/16	3/4	1.33	2.11	0.44	0.33	6.0	6.0	
6 WGTX	3/8	1/4-18	13/16	13/16	1.28	2.06	0.56	0.42	6.0	6.0	
6-6 WGTX	3/8	3/8-18	13/16	7/8	1.28	2.24	0.56	0.42	6.0	6.0	
8 WGTX	1/2	3/8-18	1	1	1.44	2.34	0.75	0.44	6.0	6.0	
8-8 WGTX	1/2	1/2-14	1	1 1/8	1.44	2.61	0.75	0.44	5.0	5.0	
10 WGTX	5/8	1/2-14	1 1/8	1 1/8	1.58	2.66	0.88	0.43	5.0	5.0	
12 WGTX	3/4	3/4-14	1 3/8	1 3/8	1.75	2.95	1.06	0.44	4.0	4.0	
14 WGTX	7/8	3/4-14	1 3/8	1 1/2	1.75	2.89	1.19	0.41	4.0		
16 WGTX	1	1-11 1/2	1 5/8	1 5/8	1.75	3.19	1.31	0.39	3.0		
24 WGTX	1 1/2	1 1/2-11 1/2	2 1/8	2 1/4	1.81	3.35	1.88	0.28	2.0	2.0	

# XHX6

Extender and Expander  
37° Flare / 37° Flare Swivel

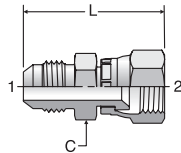

TUBE FITTING PART #	END SIZE		C HEX (in.)	L (in.)	STANDARD Dynamic Pressure (x 1,000 PSI)		
	1 (in.)	2 (in.)			-S	-SS	-B
	4 XHX6	1/4					
6 XHX6	3/8	3/8	5/8	1.50	6.0		
6-4 XHX6	3/8	1/4	5/8	1.50	6.0		
8 XHX6	1/2	1/2	13/16	1.71	6.0		
8-6 XHX6	1/2	3/8	13/16	1.72	6.0		
10 XHX6	5/8	5/8	1	2.01	5.0		
10-8 XHX6	5/8	1/2	15/16	1.93	5.0		
12 XHX6	3/4	3/4	1 1/4	2.27	5.0		
12-10 XHX6	3/4	5/8	1 1/8	2.20	5.0		
16 XHX6	1	1	1 1/2	2.47	4.0		
16-12 XHX6	1	3/4	1 1/2	2.31	4.0		
20-16 XHX6	1 1/4	1	1 11/16	2.50	4.0		

Dimensions and pressures for reference only, subject to change.

# TRTX / TRTXN

Reducer  
37° Flare

SAE 070123 / SAE 070123A  
HPD Base # 0603 (TRTXN only)

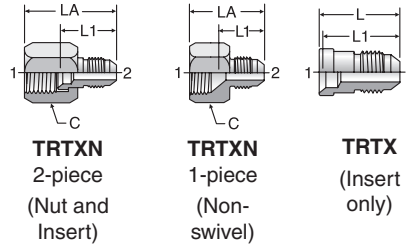

TUBE FITTING PART #			END SIZE		C HEX (in.)	L (TRTX) (in.)	LA (TRTXN) (in.)	L1 (TRTX & TRTXN) (in.)	STANDARD Dynamic Pressure (x 1,000 PSI)		
TRTXN 2-pc. Design (with Large Nut)	TRTXN 1-pc. Design (Machined Female)	TRTX Reducer Insert (For 2-pc. Design Only)	1 (in.)	2 (in.)					-S	-SS	-B
4-2 TRTXN	-	4-2 TRTX	1/4	1/8	9/16	0.75	1.23	0.68		9.0	
-	4-3 TRTXN	-	1/4	3/16	9/16	-	1.09	-		9.0	
-	5-4 TRTXN	-	5/16	1/4	5/8	-	1.16	-	6.0	7.2	
6-4 TRTXN	-	6-4 TRTX	3/8	1/4	11/16	0.97	1.53	0.90	6.0	7.2	3.3
-	6-5 TRTXN	-	3/8	5/16	11/16	-	1.19	-	6.0	7.2	
8-4 TRTXN	-	8-4 TRTX	1/2	1/4	7/8	1.00	1.63	0.90	6.0	7.2	3.3
8-6 TRTXN	-	8-6 TRTX	1/2	3/8	7/8	1.00	1.63	0.90	6.0	7.2	3.3
10-4 TRTXN	-	10-4 TRTX	5/8	1/4	1	1.03	1.78	0.93	5.0	6.0	
10-6 TRTXN	-	10-6 TRTX	5/8	3/8	1	1.03	1.78	0.93	5.0	6.0	3.3
-	10-8 TRTXN	-	5/8	1/2	1	-	1.88	-	5.0	6.0	
12-4 TRTXN	-	12-4 TRTX	3/4	1/4	1 1/4	1.09	1.85	0.95	5.0	6.0	3.3
12-6 TRTXN	-	12-6 TRTX	3/4	3/8	1 1/4	1.09	1.85	0.95	5.0	6.0	3.3
12-8 TRTXN	-	12-8 TRTX	3/4	1/2	1 1/4	1.19	1.95	1.05	5.0	6.0	3.3
-	12-10 TRTXN	-	3/4	5/8	1 1/4	-	2.05	-	5.0	6.0	
14-6 TRTXN	-	14-6 TRTX	7/8	3/8	1 3/8	1.13	1.96	1.00	5.0		
14-10 TRTXN	-	14-10 TRTX	7/8	5/8	1 3/8	1.33	2.16	1.20	5.0		
-	14-12 TRTXN	-	7/8	3/4	1 3/8	-	1.84	-	5.0		
16-4 TRTXN	-	16-4 TRTX	1	1/4	1 1/2	1.22	2.07	1.09		4.8	
16-6 TRTXN	-	16-6 TRTX	1	3/8	1 1/2	1.22	1.90	1.09		4.8	
16-8 TRTXN	-	16-8 TRTX	1	1/2	1 1/2	1.27	2.11	1.14	4.0	4.8	
16-10 TRTXN	-	16-10 TRTX	1	5/8	1 1/2	1.38	2.06	1.25	4.0		
16-12 TRTXN	-	16-12 TRTX	1	3/4	1 1/2	1.47	2.32	1.34	4.0	4.8	
-	16-14 TRTXN	-	1	7/8	1 1/2	-	2.35	-	4.0		
20-12 TRTXN	-	20-12 TRTX	1 1/4	3/4	2	1.53	2.45	1.37	4.0	4.8	
20-16 TRTXN	-	20-16 TRTX	1 1/4	1	2	1.59	2.51	1.43	4.0	4.8	
24-8 TRTXN	-	24-8 TRTX	1 1/2	1/2	2 1/4	1.56	2.39	1.41		3.6	
24-12 TRTXN	-	24-12 TRTX	1 1/2	3/4	2 1/4	1.63	2.46	1.48		3.6	
24-16 TRTXN	-	24-16 TRTX	1 1/2	1	2 1/4	1.63	2.46	1.48	3.0	3.6	
24-20 TRTXN	-	24-20 TRTX	1 1/2	1 1/4	2 1/4	1.69	2.77	1.54	3.0		
32-24 TRTXN	-	32-24 TRTX	2	1 1/2	2 7/8	1.91	2.96	1.72	2.0	2.4	

Dimensions and pressures for reference only, subject to change.



### F50X

Straight Thread Connector  
37° Flare / SAE-ORB

SAE 070120  
HPD Base # 0503

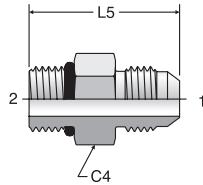

### FF50X

Long Straight Thread Connector  
37° Flare / SAE-ORB

SAE 071720  
HPD Base # 053E

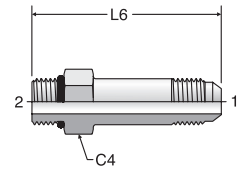

TUBE FITTING PART #	END SIZE		C4 HEX (in.)	L5 (in.)	STANDARD Dynamic Pressure (x 1,000 PSI)		
	1 (in.)	2 UN/UNF-2A			-S	-SS	-B
	2 F50X	1/8					
3 F50X	3/16	3/8-24	1/2	1.10	7.5	9.0	
3-2 F50X	3/16	5/16-24	1/2	1.10		9.0	
4 F50X	1/4	7/16-20	9/16	1.23	7.5	9.0	
4-2 F50X	1/4	5/16-24	9/16	1.02	7.5		
4-3 F50X	1/4	3/8-24	9/16	1.19		9.0	
4-5 F50X	1/4	1/2-20	5/8	1.23	6.0	7.2	
4-6 F50X	1/4	9/16-18	11/16	1.28	6.0	7.2	
4-8 F50X	1/4	3/4-16	7/8	1.38	6.0	7.2	
4-10 F50X	1/4	7/8-14	1	1.49	5.0		
5 F50X	5/16	1/2-20	5/8	1.23	6.0	7.2	
5-4 F50X	5/16	7/16-20	9/16	1.23	6.0		
5-6 F50X	5/16	9/16-18	11/16	1.30	6.0		
5-8 F50X	5/16	3/4-16	7/8	1.37	6.0		
6 F50X	3/8	9/16-18	11/16	1.30	6.0	7.2	
6-4 F50X	3/8	7/16-20	5/8	1.27	6.0	7.2	
6-5 F50X	3/8	1/2-20	5/8	1.27	6.0		
6-8 F50X	3/8	3/4-16	7/8	1.38	6.0	7.2	
6-10 F50X	3/8	7/8-14	1	1.50	5.0	6.0	
6-12 F50X	3/8	1 1/16-12	1 1/4	1.66	5.0	6.0	
8 F50X	1/2	3/4-16	7/8	1.48	6.0	7.2	
8-4 F50X	1/2	7/16-20	13/16	1.50	6.0	7.2	
8-6 F50X	1/2	9/16-18	13/16	1.44	6.0	7.2	
8-10 F50X	1/2	7/8-14	1	1.59	5.0	6.0	
8-12 F50X	1/2	1 1/16-12	1 1/4	1.77	5.0	6.0	
8-16 F50X	1/2	1 5/16-12	1 1/2	1.78	4.5	5.4	
10 F50X	5/8	7/8-14	1	1.70	5.0	6.0	
10-6 F50X	5/8	9/16-18	11/16	1.71	5.0	6.0	
10-8 F50X	5/8	3/4-16	15/16	1.64	5.0	6.0	
10-12 F50X	5/8	1 1/16-12	1 1/4	1.86	5.0	6.0	
10-16 F50X	5/8	1 5/16-12	1 1/2	1.89	4.5	5.4	
12 F50X	3/4	1 1/16-12	1 1/4	1.97	5.0	6.0	
12-8 F50X	3/4	3/4-16	1 1/8	1.94	5.0	6.0	
12-10 F50X	3/4	7/8-14	1 1/8	1.88	5.0	6.0	
12-14 F50X	3/4	1 3/16-12	1 3/8	1.96	5.0		
12-16 F50X	3/4	1 5/16-12	1 1/2	1.99	4.5	5.4	
12-20 F50X	3/4	1 5/8-12	1 7/8	2.08	4.0		
14 F50X	7/8	1 3/16-12	1 3/8	1.99	5.0		
14-16 F50X	7/8	1 5/16-12	1 1/2	2.02	4.5		
16 F50X	1	1 5/16-12	1 1/2	2.05	4.5	5.4	
16-8 F50X	1	3/4-16	1 3/8	1.78	4.5	5.4	
16-10 F50X	1	7/8-14	1 3/8	2.08	4.5	5.4	
16-12 F50X	1	1 1/16-12	1 3/8	1.99	4.5	5.4	
16-14 F50X	1	1 3/16-12	1 3/8	2.05	4.5		
16-20 F50X	1	1 5/8-12	1 7/8	2.13	4.0	4.8	
16-24 F50X	1	1 7/8-12	2 1/8	2.20	3.0		
20 F50X	1 1/4	1 5/8-12	1 7/8	2.17	4.0	4.8	
20-12 F50X	1 1/4	1 1/16-12	1 11/16	2.30	4.0	4.8	
20-16 F50X	1 1/4	1 5/16-12	1 11/16	2.33	4.0	4.8	
20-24 F50X	1 1/4	1 7/8-12	2 1/8	2.24	3.0	3.6	
24 F50X	1 1/2	1 7/8-12	2 1/8	2.38	3.0	3.6	
24-20 F50X	1 1/2	1 5/8-12	2	2.53	3.0	3.6	
24-32 F50X	1 1/2	2 1/2-12	2 3/4	2.53	2.0		
32 F50X	2	2 1/2-12	2 3/4	2.78	2.0	2.4	
32-24 F50X	2	1 7/8-12	2 5/8	2.94	2.0		

TUBE FITTING PART #	END SIZE		C4 HEX (in.)	L6 (in.)	STANDARD Dynamic Pressure (x 1,000 PSI)		
	1 (in.)	2 UN/UNF-2A			-S	-SS	-B
	4 FF50X	1/4					
4-6 FF50X	1/4	9/16-18	11/16	2.13		7.2	
6 FF50X	3/8	9/16-18	11/16	2.31	6.0	7.2	
8 FF50X	1/2	3/4-16	7/8	2.70	6.0	7.2	
10 FF50X	5/8	7/8-14	1	3.03	5.0	6.0	
12 FF50X	3/4	1 1/16-12	1 1/4	3.61	5.0	6.0	
16 FF50X	1	1 5/16-12	1 1/2	3.98	4.5	5.4	
20 FF50X	1 1/4	1 5/8-12	1 7/8	4.69	4.0		

### XHB3

Braze Socket  
37° Flare / Inch Tube Braze

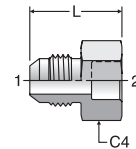

TUBE FITTING PART #	END SIZE		C4 HEX (in.)	L (in.)	STANDARD Dynamic Pressure (x 1,000 PSI)		
	1 (in.)	2 (in.)			-S	-SS	-B
	4 XHB3	1/4					
6 XHB3	3/8	3/8	5/8	1.00	6.0		
6-4 XHB3	3/8	1/4	5/8	1.00	6.0		
6-8 XHB3	3/8	1/2	5/8	1.00	6.0		
8 XHB3	1/2	1/2	13/16	1.12	6.0		
8-10 XHB3	1/2	5/8	13/16	1.12	5.0		
10 XHB3	5/8	5/8	15/16	1.21	5.0		
10-8 XHB3	5/8	1/2	15/16	1.21	5.0		
10-12 XHB3	5/8	3/4	1 1/8	1.37	5.0		
12 XHB3	3/4	3/4	1 1/4	1.51	5.0		
12-10 XHB3	3/4	5/8	1 1/8	1.51	5.0		
12-16 XHB3	3/4	1	1 1/4	1.57	4.0		
16 XHB3	1	1	1 3/8	1.63	4.0		
16-20 XHB3	1	1 1/4	1 11/16	1.73	4.0		
20 XHB3	1 1/4	1 1/4	1 11/16	1.71	4.0		
20-24 XHB3	1 1/4	1 1/2	2	1.71	3.0		
24 XHB3	1 1/2	1 1/2	2	1.84	3.0		
32 XHB3	2	2	2 5/8	2.16			

Note: Braze rings are on [page C15](#).

Dimensions and pressures for reference only, subject to change.

# FTX

Male Connector  
37° Flare / NPTF

SAE 070102  
HPD Base # 0103

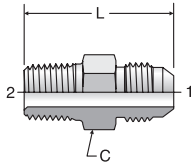

TUBE FITTING PART #	END SIZE		C HEX (in.)	L (in.)	STANDARD Dynamic Pressure (x 1,000 PSI)		
	1 (in.)	2 NPTF			-S	-SS	-B
2 FTX	1/8	1/8-27	7/16	1.11	6.0	6.0	3.3
3 FTX	3/16	1/8-27	7/16	1.14	6.0	6.0	3.3
4 FTX	1/4	1/8-27	1/2	1.22	6.0	6.0	3.3
4-4 FTX	1/4	1/4-18	9/16	1.42	6.0	6.0	3.3
4-6 FTX	1/4	3/8-18	3/4	1.44	6.0	6.0	
4-8 FTX	1/4	1/2-14	7/8	1.69	6.0	6.0	3.3
5 FTX	5/16	1/8-27	9/16	1.22	6.0	6.0	3.3
5-4 FTX	5/16	1/4-18	9/16	1.42	6.0	6.0	3.3
5-6 FTX	5/16	3/8-18	3/4	1.44	6.0	6.0	
6 FTX	3/8	1/4-18	5/8	1.43	6.0	6.0	3.3
6-2 FTX	3/8	1/8-27	5/8	1.24	6.0	6.0	3.3
6-6 FTX	3/8	3/8-18	3/4	1.44	6.0	6.0	3.3
6-8 FTX	3/8	1/2-14	7/8	1.69	6.0	6.0	3.3
6-12 FTX	3/8	3/4-14	1 1/8	1.75	5.5	5.5	
8 FTX	1/2	3/8-18	13/16	1.53	6.0	6.0	3.3
8-2 FTX	1/2	1/8-27	1 3/16	1.34	6.0	6.0	
8-4 FTX	1/2	1/4-18	13/16	1.53	6.0	6.0	3.3
8-8 FTX	1/2	1/2-14	7/8	1.78	6.0	6.0	3.3
8-12 FTX	1/2	3/4-14	1 1/8	1.85	5.5	5.5	2.6
8-16 FTX	1/2	1-11 1/2	1 3/8	2.05	4.5	4.5	
10 FTX	5/8	1/2-14	15/16	1.89	5.0	5.0	3.3
10-6 FTX	5/8	3/8-18	15/16	1.70	5.0	5.0	3.3
10-12 FTX	5/8	3/4-14	1 1/8	1.95	5.0	5.0	
12 FTX	3/4	3/4-14	1 1/8	2.06	5.0	5.0	2.6
12-6 FTX	3/4	3/8-18	1 1/8	1.88	5.0	5.0	
12-8 FTX	3/4	1/2-14	1 1/8	2.06	5.0	5.0	2.9
12-16 FTX	3/4	1-11 1/2	1 3/8	2.25	5.0	5.0	
12-20 FTX	3/4	1 1/4-11 1/2	1 11/16	2.36	5.0		
14 FTX	7/8	3/4-14	1 1/4	2.09	5.0	5.0	2.9
16 FTX	1	1-11 1/2	1 3/8	2.30	4.5	4.5	2.0
16-8 FTX	1	1/2-14	1 3/8	2.11	4.5	4.5	
16-12 FTX	1	3/4-14	1 3/8	2.11	4.5	4.5	2.3
16-20 FTX	1	1 1/4-11 1/2	1 11/16	2.41	3.0	3.0	
16-24 FTX	1	1 1/2-11 1/2	2	2.50	3.0	3.0	
20 FTX	1 1/4	1 1/4-11 1/2	1 11/16	2.45	3.0	3.0	1.6
20-16 FTX	1 1/4	1-11 1/2	1 11/16	2.42	3.0	3.0	
20-24 FTX	1 1/4	1 1/2-11 1/2	2	2.55	3.0	3.0	
24 FTX	1 1/2	1 1/2-11 1/2	2	2.67	3.0	3.0	1.3
24-16 FTX	1 1/2	1-11 1/2	2	2.62	3.0	3.0	
24-20 FTX	1 1/2	1 1/4-11 1/2	2	2.66	3.0		
24-32 FTX	1 1/2	2-11 1/2	2 5/8	2.86	2.0		
32 FTX	2	2-11 1/2	2 5/8	3.11	2.0	2.0	
32-24 FTX	2	1 1/2-11 1/2	2 5/8	3.08	2.0	2.0	
40 FTX	2 1/2	2 1/2-8	3 1/4	3.38	1.0		

# FFTX

Long Male Connector  
37° Flare / NPTF

SAE 071802  
HPD Base # 013E

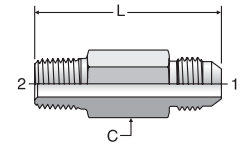

TUBE FITTING PART #	END SIZE		C (in.)	L (in.)	STANDARD Dynamic Pressure (x 1,000 PSI)		
	1 (in.)	2 NPTF			-S	-SS	-B
4 FFTX	1/4	1/8-27	1/2	1.81	6.0	6.0	
4-4 FFTX	1/4	1/4-18	9/16	2.25	6.0	6.0	
6 FFTX	3/8	1/4-18	5/8	2.25	6.0	6.0	
6-6 FFTX	3/8	3/8-18	3/4	2.50	6.0	6.0	
8 FFTX	1/2	3/8-18	13/16	2.75	6.0		
8-8 FFTX	1/2	1/2-14	15/16	2.80	6.0		
10 FFTX	5/8	1/2-14	15/16	3.12	5.0		
12 FFTX	3/4	3/4-14	1 1/8	3.50	5.0	5.0	

# GTX

Female Connector  
37° Flare / NPTF

SAE 070103  
HPD Base # 0203

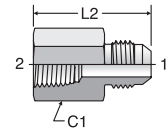

TUBE FITTING PART #	END SIZE		C1 HEX (in.)	L2 (in.)	STANDARD Dynamic Pressure (x 1,000 PSI)		
	1 (in.)	2 NPTF			-S	-SS	-B
2 GTX	1/8	1/8-27	9/16	1.12	6.0	6.0	3.3
3 GTX	3/16	1/8-27	9/16	1.13			3.3
4 GTX	1/4	1/8-27	9/16	1.19	6.0	6.0	3.3
4-4 GTX	1/4	1/4-18	3/4	1.39	6.0	6.0	3.3
4-6 GTX	1/4	3/8-18	7/8	1.45		6.0	
4-8 GTX	1/4	1/2-14	1 1/8	1.68		6.0	
5 GTX	5/16	1/8-27	9/16	1.17	6.0		3.3
5-4 GTX	5/16	1/4-18	3/4	1.39	6.0	6.0	3.3
6 GTX	3/8	1/4-18	3/4	1.41	6.0	6.0	3.3
6-2 GTX	3/8	1/8-27	5/8	1.19		6.0	
6-6 GTX	3/8	3/8-18	7/8	1.46	6.0	6.0	3.3
6-8 GTX	3/8	1/2-14	1 1/8	1.69	5.0	5.0	
8 GTX	1/2	3/8-18	7/8	1.56	6.0	6.0	3.3
8-4 GTX	1/2	1/4-18	13/16	1.55	6.0	6.0	
8-8 GTX	1/2	1/2-14	1 1/8	1.79	5.0	5.0	3.3
8-12 GTX	1/2	3/4-14	1 3/8	1.85	4.0	4.0	
10 GTX	5/8	1/2-14	1 1/8	1.89	5.0	5.0	3.3
10-12 GTX	5/8	3/4-14	1 3/8	1.95	4.0	4.0	
12 GTX	3/4	3/4-14	1 3/8	2.06	4.0	4.0	2.6
12-8 GTX	3/4	1/2-14	1 1/8	2.05	5.0	5.0	2.6
12-16 GTX	3/4	1-11 1/2	1 5/8	2.30	3.0	3.0	
14 GTX	7/8	3/4-14	1 3/8	2.06	4.0		
16 GTX	1	1-11 1/2	1 5/8	2.35	3.0	3.0	2.0
16-12 GTX	1	3/4-14	1 3/8	2.13	4.0	4.0	
16-20 GTX	1	1 1/4-11 1/2	2	2.44	2.5	2.5	
20 GTX	1 1/4	1 1/4-11 1/2	2	2.49	2.5	2.5	
20-16 GTX	1 1/4	1-11 1/2	1 3/4	2.47	3.0	3.0	
24 GTX	1 1/2	1 1/2-11 1/2	2 3/8	2.62	2.0	2.0	
32 GTX	2	2-11 1/2	2 7/8	2.97	1.5	1.5	

Dimensions and pressures for reference only, subject to change.



### F87OMX

Male Connector – ISO 6149  
37° Flare / ISO 6149

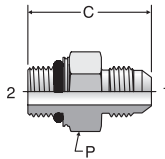

TUBE FITTING PART #	END SIZE			C (mm)	P (mm)	STANDARD Dynamic Pressure (x 1,000 PSI)		
	1		Male Metric Parallel Thread			-S	-SS	-B
	(mm)	(in.)						
4M10F87OMX	6	1/4	M10x1	30.5	14	7.2		
5M12F87OMX	8	5/16	M12x1.5	33.5	19	6.0		
6M14F87OMX	10	3/8	M14x1.5	33.5	19	6.0		
6M16F87OMX	10	3/8	M16x1.5	35.1	22	6.0		
8M16F87OMX	12	1/2	M16x1.5	37.6	22	6.0		
8M18F87OMX	12	1/2	M18x1.5	39.1	24	5.0		
10M18F87OMX	14, 15, 16	5/8	M18x1.5	41.7	24	5.0		
10M22F87OMX	14, 15, 16	5/8	M22x1.5	42.9	27	5.0		
12M22F87OMX	18, 20	3/4	M22x1.5	45.5	27	5.0		
12M27F87OMX	18, 20	3/4	M27x2	49.0	32	5.0		
16M27F87OMX	25	1	M27x2	50.5	36	5.0		
16M33F87OMX	25	1	M33x2	51.6	41	4.0		
20M42F87OMX	30, 32	1 1/4	M42x2	54.9	50	4.0		
24M48F87OMX	38	1 1/2	M48x2	59.4	55	3.0		

### F82EDMX

Male Connector – Metric  
37° Flare / Metric-ED

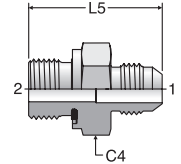

TUBE FITTING PART #	END SIZE			C4 (mm)	L5 (mm)	STANDARD Dynamic Pressure (x 1,000 PSI)		
	1		Male Metric Parallel Thread			-S	-SS	-B
	(mm)	(in.)						
4M10F82EDMX	6	1/4	M10x1	14	31.0	7.2		
5M12F82EDMX	8	5/16	M12x1.5	17	33.5	6.0		
6M14F82EDMX	10	3/8	M14x1.5	19	33.5	6.0		
6M16F82EDMX	10	3/8	M16x1.5	22	35.1	6.0		
8M16F82EDMX	12	1/2	M16x1.5	22	37.6	6.0		
8M18F82EDMX	12	1/2	M18x1.5	24	39.1	5.0		
10M18F82EDMX	14, 15, 16	5/8	M18x1.5	24	41.7	5.0		
10M22F82EDMX	14, 15, 16	5/8	M22x1.5	27	42.9	5.0		
12M22F82EDMX	18, 20	3/4	M22x1.5	27	45.5	5.0		
12M27F82EDMX	18, 20	3/4	M27x2	32	49.0	5.0		
16M33F82EDMX	25	1	M33x2	41	51.6	4.0		
20M42F82EDMX	30, 32	1 1/4	M42x2	50	54.9	4.0		

### F80MX

Male Connector – Metric  
37° Flare / Metric-ORR

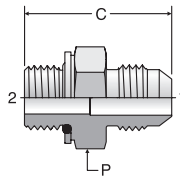

TUBE FITTING PART #	END SIZE			C (mm)	P (mm)	STANDARD Dynamic Pressure (x 1,000 PSI)		
	1		Male Metric Parallel Thread			-S	-SS	-B
	(mm)	(in.)						
4M10F80MX	6	1/4	M10x1	31.0	16	5.0		
5M12F80MX	8	5/16	M12x1.5	33.5	19	5.0		
6M14F80MX	10	3/8	M14x1.5	33.5	19	5.0		
8M16F80MX	12	1/2	M16x1.5	37.6	22	5.0		
8M18F80MX	12	1/2	M18x1.5	39.1	24	3.6		
10M18F80MX	14, 15, 16	5/8	M18x1.5	41.7	24	3.6		
10M22F80MX	14, 15, 16	5/8	M22x1.5	42.9	27	3.6		
12M22F80MX	18, 20	3/4	M22x1.5	45.5	27	3.6		
12M24F80MX	18, 20	3/4	M24x1.5	44.5	30	3.0		
12M27F80MX	18, 20	3/4	M27x2	49.0	32	3.0		
16M27F80MX	25	1	M27x2	50.5	36	3.0		
16M33F80MX	25	1	M33x2	51.6	41	3.0		
20M42F80MX	30, 32	1 1/4	M42x2	54.9	50	3.0		
24M48F80MX	38	1 1/2	M48x2	59.4	55			

Note: If F80MX is not available, use F82EDMX.

### F42EDMX

Male Connector – BSPP  
37° Flare / BSPP-ED

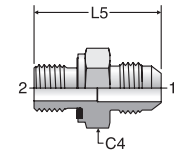

TUBE FITTING PART #	END SIZE			C4 (mm)	L5 (mm)	STANDARD Dynamic Pressure (x 1,000 PSI)		
	1		BSPP			-S	-SS	-B
	(mm)	(in.)						
4F42EDMX	6	1/4	1/8-28	14	30.0	7.2		
4-4F42EDMX	6	1/4	1/4-19	19	34.8	6.0	6.0	
4-6F42EDMX	6	1/4	3/8-19	22	35.7	6.0		
4-8F42EDMX	6	1/4	1/2-14	30	39.2	5.0		
5F42EDMX	8	5/16	1/8-28	14	30.0	6.0		
5-4F42EDMX	8	5/16	1/4-19	19	34.8	6.0		
5-6F42EDMX	8	5/16	3/8-19	22	35.7	6.0		
6-2F42EDMX	10	3/8	1/8-28	16	31.0	6.0		
6F42EDMX	10	3/8	1/4-19	19	35.1	6.0		
6-6F42EDMX	10	3/8	3/8-19	22	36.0	6.0		
6-8F42EDMX	10	3/8	1/2-14	30	39.4	5.0		
8F42EDMX	12	1/2	3/8-19	22	33.5	6.0		
8-4F42EDMX	12	1/2	1/4-19	19	38.7	6.0		
8-8F42EDMX	12	1/2	1/2-14	30	42.0	5.0		
8-12F42EDMX	12	1/2	3/4-14	36	45.6	5.0		
10F42EDMX	14, 15, 16	5/8	1/2-14	30	44.5	5.0		
10-6F42EDMX	14, 15, 16	5/8	3/8-19	24	42.6	5.0		
10-12F42EDMX	14, 15, 16	5/8	3/4-14	32	48.1	5.0		
12F42EDMX	18, 20	3/4	3/4-14	36	50.9	5.0		
12-6F42EDMX	18, 20	3/4	3/8-19	27	50.1	5.0		
12-8F42EDMX	18, 20	3/4	1/2-14	30	49.0	5.0		
12-16F42EDMX	18, 20	3/4	1-11	46	53.4	4.0		
16F42EDMX	25	1	1-11	46	54.7	4.0		
16-12F42EDMX	25	1	3/4-14	36	52.7	4.5		
16-20F42EDMX	25	1	1 1/4-11	50	58.7	4.0		
20-16F42EDMX	30, 32	1 1/4	1-11	46	62.1	4.0		
20F42EDMX	30, 32	1 1/4	1 1/4-11	50	60.0	4.0		
20-24F42EDMX	30, 32	1 1/4	1 1/2-11	55	63.8	3.0		
24F42EDMX	38	1 1/2	1 1/2-11	55	67.1	3.0		
24-20F42EDMX	38	1 1/2	1 1/4-11	50	63.8	3.0		

Dimensions and pressures for reference only, subject to change.



### F4OMX

Male Connector – BSPP  
37° Flare / BSPP-ORR

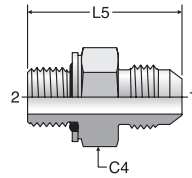

TUBE FITTING PART #	END SIZE			C4 (mm)	L5 (mm)	STANDARD Dynamic Pressure (x 1,000 PSI)		
	1		2			-S	-SS	-B
	(mm)	(in.)	BSPP					
4F4OMX	6	1/4	1/8-28	17	28.7	5.0		
4-4F4OMX	6	1/4	1/4-19	19	32.0	5.0		
4-6F4OMX	6	1/4	3/8-19	22	33.0	5.0		
4-8F4OMX	6	1/4	1/2-14	30	38.6	5.0		
5-4F4OMX	8	5/16	1/4-19	19	32.0	5.0		
5-6F4OMX	8	5/16	3/8-19	22	33.0	5.0		
6F4OMX	10	3/8	1/4-19	19	32.0	5.0		
6-6F4OMX	10	3/8	3/8-19	22	33.0	5.0		
6-8F4OMX	10	3/8	1/2-14	30	38.6	5.0		
8-4F4OMX	12	1/2	1/4-19	19	35.0	5.0		
8F4OMX	12	1/2	3/8-19	22	36.0	5.0		
8-8F4OMX	12	1/2	1/2-14	30	41.4	5.0		
8-12F4OMX	12	1/2	3/4-14	36	42.4	4.0		
10-6F4OMX	14, 15, 16	5/8	3/8-19	24	39.1	5.0		
10F4OMX	14, 15, 16	5/8	1/2-14	30	43.9	5.0		
12-8F4OMX	18, 20	3/4	1/2-14	30	46.7	5.0		
12F4OMX	18, 20	3/4	3/4-14	36	47.5	4.0		
12-16F4OMX	18, 20	3/4	1-11	46	52.6	4.0		
16-12F4OMX	25	1	3/4-14	36	48.5	4.0		
16F4OMX	25	1	1-11	46	53.6	4.0		
16-20F4OMX	25	1	1 1/4-11	50	55.1	3.6		
20F4OMX	30, 32	1 1/4	1 1/4-11	50	56.9	3.6		
24-20F4OMX	38	1 1/2	1 1/4-11	50	60.4	3.0		
24F4OMX	38	1 1/2	1 1/2-11	55	61.0	3.0		

Note: If F4OMX is not available, use F42EDMX.

### F3MX

Male Connector – BSPT  
37° Flare / BSPT

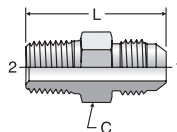

TUBE FITTING PART #	END SIZE			C HEX (mm)	L (mm)	STANDARD Dynamic Pressure (x 1,000 PSI)		
	1		2			-S	-SS	-B
	(mm)	(in.)	BSPT					
4F3MX	6	1/4	1/8-28	13	31.0	4.5		
4-4F3MX	6	1/4	1/4-19	14	36.0	4.5		
5F3MX	8	5/16	1/8-28	14	31.0	4.5		
5-4F3MX	8	5/16	1/4-19	14	36.0	4.5		
6F3MX	10	3/8	1/4-19	16	36.3	4.5		
6-6F3MX	10	3/8	3/8-19	19	36.4	4.5		
6-8F3MX	10	3/8	1/2-14	22	42.9	4.5		
8-4F3MX	12	1/2	1/4-19	19	38.9	4.5		
8F3MX	12	1/2	3/8-19	19	38.9	4.5		
8-8F3MX	12	1/2	1/2-14	22	45.5	4.5		
10-6F3MX	14,15,16	5/8	3/8-19	24	43.2	4.5		
10F3MX	14,15,16	5/8	1/2-14	24	48.0	4.5		
10-12F3MX	14,15,16	5/8	3/4-14	27	49.5	2.3		
12-8F3MX	18,20	3/4	1/2-14	27	52.3	4.5		
12F3MX	18,20	3/4	3/4-14	27	52.3	2.3		
12-16F3MX	18,20	3/4	1-11	36	57.1	2.3		
16-12F3MX	25	1	3/4-14	36	53.6	2.3		
16F3MX	25	1	1-11	36	58.4	2.3		
20-16F3MX	30,32	1 1/4	1-11	46	61.4	2.3		
20F3MX	30,32	1 1/4	1 1/4-11	46	62.2	2.3		
24F3MX	38	1 1/2	1 1/2-11	50	68.1	2.3		

Dimensions and pressures for reference only, subject to change.

### G4MX

Female Connector – BSPP  
37° Flare / BSPP

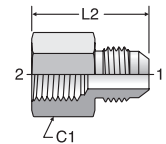

TUBE FITTING PART #	END SIZE			C1 (mm)	L2 (mm)	STANDARD Dynamic Pressure (x 1,000 PSI)		
	1		2			S	SS	B
	(mm)	(in.)	BSPP					
4G4MX	6	1/4	1/8-28	16	30.2	5.0		
4-4G4MX	6	1/4	1/4-19	19	35.3	5.0		
5G4MX	8	5/16	1/8-28	16	29.7	5.0		
6G4MX	10	3/8	1/4-19	19	35.6	5.0		
6-6G4MX	10	3/8	3/8-19	22	37.1	5.0		
8G4MX	12	1/2	3/8-19	22	39.6	5.0		
8-8G4MX	12	1/2	1/2-14	30	45.5	5.0		
10G4MX	14,15,16	5/8	1/2-14	30	48.0	5.0		
12G4MX	18,20	3/4	3/4-14	36	52.3	4.0		
16G4MX	25	1	1-11	46	59.7	4.0		

### HX6

Swivel Nut Union  
37° Swivel / 37° Swivel

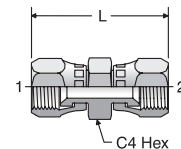

HPD Base # 0606

TUBE FITTING PART #	END SIZE		C4 HEX (in.)	L (in.)	STANDARD Dynamic Pressure (x 1,000 PSI)		
	1 & 2 (in.)				-S	-SS	-B
4 HX6	1/4	9/16	1.48	7.5	7.5		
6 HX6	3/8	11/16	1.75	6.0			
8 HX6	1/2	7/8	2.02	6.0			
10 HX6	5/8	1	2.24	5.0			
12 HX6	3/4	1 1/4	2.43	5.0			
16 HX6	1	1 1/2	2.68	4.0			

### F650X

Swivel Straight Thread Connector  
37° Swivel / SAE-ORB

HPD Base # 0506

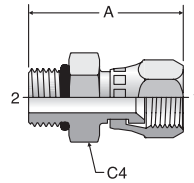

TUBE FITTING PART #	END SIZE		A (in.)	C4 HEX (in.)	STANDARD Dynamic Pressure (x 1,000 PSI)		
	1 (in.)	2 UN/UNF-2A			-S	-SS	-B
4 F650X	1/4	7/16-20	1.31	9/16	7.5	9.0	
4-6 F650X	1/4	9/16-18	1.37	11/16	6.0		
5 F650X	5/16	1/2-20	1.35	5/8	6.0		
6 F650X	3/8	9/16-18	1.43	11/16	6.0	7.2	
6-4 F650X	3/8	7/16-20	1.37	9/16	6.0		
6-8 F650X	3/8	3/4-16	1.50	7/8	6.0	7.2	
8 F650X	1/2	3/4-16	1.61	7/8	6.0	7.2	
8-6 F650X	1/2	9/16-18	1.54	13/16	6.0		
8-10 F650X	1/2	7/8-14	1.88	7/8	5.0		
10 F650X	5/8	7/8-14	1.84	1	5.0	6.0	
10-8 F650X	5/8	3/4-16	1.67	1	5.0		
10-12 F650X	5/8	1 1/16-12	1.92	1 1/4	5.0		
12 F650X	3/4	1 1/16-12	2.07	1 1/4	5.0	6.0	
12-10 F650X	3/4	7/8-14	2.10	1 1/4	5.0		
12-16 F650X	3/4	1 5/16-12	2.24	1 1/2	4.5		
16 F650X	1	1 5/16-12	2.28	1 1/2	4.0	4.8	
16-12 F650X	1	1 1/16-12	2.14	1 1/2	4.5		
20 F650X	1 1/4	1 5/8-12	2.49	2	4.0	4.8	

### F6X

Swivel Connector  
37° Swivel / NPTF

HPD Base # 0106

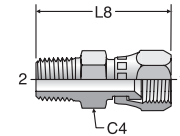

TUBE FITTING PART #	END SIZE		C4 (in.)	L8 (in.)	STANDARD Dynamic Pressure (x 1,000 PSI)		
	1 (in.)	2 NPTF			-S	-SS	-B
4 F6X	1/4	1/8-27	9/16	1.13	6.0	6.0	
4-4 F6X	1/4	1/4-18	9/16	1.46	6.0	6.0	
5-4 F6X	5/16	1/4-18	5/8	1.57	6.0		
6 F6X	3/8	1/4-18	11/16	1.59	5.0	5.0	
6-6 F6X	3/8	3/8-18	3/4	1.59	5.0	5.0	
8 F6X	1/2	3/8-18	7/8	1.69	5.0	5.0	
8-8 F6X	1/2	1/2-14	7/8	1.92	5.0	5.0	
10 F6X	5/8	1/2-14	1	2.05	5.0	5.0	
10-6 F6X	5/8	3/8-18	1	1.87	5.0		
12 F6X	3/4	3/4-14	1 1/4	2.15	5.0	5.0	
12-8 F6X	3/4	1/2-14	1 1/4	2.15	5.0	5.0	
16 F6X	1	1-11 1/2	1 1/2	2.50	3.6	3.6	
16-12 F6X	1	3/4-14	1 1/2	2.33	3.6		
20 F6X	1 1/4	1 1/4-11 1/2	2	2.76	3.0	3.0	
24 F6X	1 1/2	1 1/2-11 1/2	2 1/4	3.05	2.5	2.5	
32 F6X	2	2-11 1/2	2 5/8	3.38		2.0	

### G6X

Swivel Nut Female Connector  
37° Swivel / NPTF

HPD Base # 0206

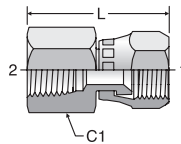

TUBE FITTING PART #	END SIZE		C1 (in.)	L (in.)	STANDARD Dynamic Pressure (x 1,000 PSI)		
	1 (in.)	2 NPTF			-S	-SS	-B
4 G6X	1/4	1/8-27	9/16	1.27	6.0	6.0	
4-4 G6X	1/4	1/4-18	3/4	1.43	6.0	6.0	
6 G6X	3/8	1/4-18	3/4	1.44	5.0	5.0	
6-6 G6X	3/8	3/8-18	7/8	1.54	5.0	5.0	
6-8 G6X	3/8	1/2-14	1 1/8	1.80	5.0	5.0	
8 G6X	1/2	3/8-18	7/8	1.69	5.0	5.0	
8-8 G6X	1/2	1/2-14	1 1/8	1.94	5.0	5.0	
10 G6X	5/8	1/2-14	1 1/8	1.98	5.0	5.0	
12 G6X	3/4	3/4-14	1 3/8	2.08	4.0	4.0	
12-8 G6X	3/4	1/2-14	1 1/4	2.07		5.0	
16 G6X	1	1-11 1/2	1 5/8	2.45	3.0	3.0	
20 G6X	1 1/4	1 1/4-11 1/2	2	2.81	2.5	2.5	
24 G6X	1 1/2	1 1/2-11 1/2	2 3/8	3.01	2.0	2.0	
32 G6X	2	2-11 1/2	2 7/8	3.40	1.5	1.5	

### F6870MX

Swivel – ISO 6149 Connector  
37° Swivel / ISO 6149

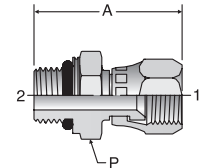

TUBE FITTING PART #	END SIZE		A (mm)	P (mm)	STANDARD Dynamic Pressure (x 1,000 PSI)		
	1 (mm)	2 Male Metric Parallel Thread			-S	-SS	-B
4M10F6870MX	6	1/4 M10x1	33.8	16	7.2		
5M12F6870MX	8	5/16 M12x1.5	44.0	22	6.0		
6M14F6870MX	10	3/8 M14x1.5	45.7	22	6.0		
8M16F6870MX	12	1/2 M16x1.5	46.6	27	6.0		
10M22F6870MX	14, 15, 16	5/8 M22x1.5	48.6	27	5.0		
12M27F6870MX	18, 20	3/4 M27x2	53.9	32	5.0		
16M33F6870MX	25	1 M33x2	57.5	38	4.0		

Dimensions and pressures for reference only, subject to change.



### F68OMX

Swivel Metric ORR Connector  
Metric-ORR / 37° Swivel

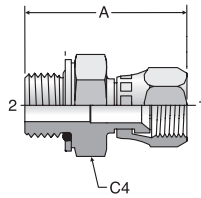

TUBE FITTING PART #	END SIZE		Male Metric Parallel Thread	A (mm)	C4 (mm)	STANDARD Dynamic Pressure (x 1,000 PSI)		
	1	2				-S	-SS	-B
	(mm)	(in.)						
4M10F68OMX	6	1/4	M10x1	34.3	16	5.0		
5M12F68OMX	8	5/16	M12x1.5	37.9	19	5.0		
6M14F68OMX	10	3/8	M14x1.5	38.5	19	5.0		
8M16F68OMX	12	1/2	M16x1.5	42.4	22	5.0		
10M22F68OMX	14, 15, 16	5/8	M22x1.5	47.9	27	3.6		
12M27F68OMX	18, 20	3/4	M27x2	52.3	32	3.0		
16M33F68OMX	25	1	M33x2	57.4	41	3.0		

### F682EDMX

Metric-ED / 37° Swivel

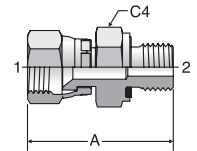

TUBE FITTING PART #	END SIZE		Male Metric Parallel Thread	A (mm)	C4 (mm)	STANDARD Dynamic Pressure (x 1,000 PSI)		
	1	2				-S	-SS	-B
	(mm)	(in.)						
4M10F682EDMX	6	1/4	M10x1	24.0	14			
5M12F682EDMX	8	5/16	M12x1.5	28.8	17			
6M14F682EDMX	10	3/8	M14x1.5	30.4	19			
8M16F682EDMX	12	1/2	M16x1.5	33.5	22	6.0		
10M22F682EDMX	14, 15, 16	5/8	M22x1.5	37.6	27			
12M27F682EDMX	18, 20	3/4	M27x2	41.5	32	5.0		
16M33F682EDMX	25	1	M33x2	45.2	41	4.0		

### F642EDMX

Swivel – BSPP Connector  
37° Swivel / BSPP-ED

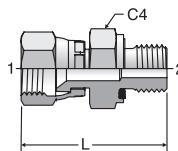

TUBE FITTING PART #	END SIZE		BSPP	C4 (mm)	L (mm)	STANDARD Dynamic Pressure (x 1,000 PSI)		
	1	2				-S	-SS	-B
	(mm)	(in.)						
4F642EDMX	6	1/4	1/8-28	14	24.0	7.2	7.2	
4-4F642EDMX	6	1/4	1/4-19	19	29.0	6.0		
5F642EDMX	8	5/16	1/8-28	14	25.0			
5-4F642EDMX	8	5/16	1/4-19	19	29.0	6.0		
6F642EDMX	10	3/8	1/4-19	19	30.0	6.0		
6-6F642EDMX	10	3/8	3/8-19	22	31.0	6.0		
8F642EDMX	12	1/2	3/8-19	22	33.0	6.0		
8-4F642EDMX	12	1/2	1/4-19	19	33.0	6.0		
10F642EDMX	14, 15, 16	5/8	1/2-14	27	37.0	5.0		
10-6F642EDMX	14, 15, 16	5/8	3/8-19	22	35.0	5.0		
12F642EDMX	18, 20	3/4	3/4-14	32	42.0	5.0		
12-8F642EDMX	18, 20	3/4	1/2-14	27	40.0	5.0		
16F642EDMX	25	1	1-11	41	45.0	4.0		
16-12F642EDMX	25	1	3/4-14	36	43.0			
20F642EDMX	28, 30, 32	1 1/4	1 1/4-11	50	52.0	4.0		
20-16F642EDMX	28, 30, 32	1 1/4	1-11	41	54.0	4.0		
24F642EDMX	35, 38	1 1/2	1 1/2-11	55	58.0			
24-20F642EDMX	35, 38	1 1/2	1 1/4-11	50	60.0	3.0		

### F63MX

Swivel – BSPT Connector  
37° Swivel / BSPT

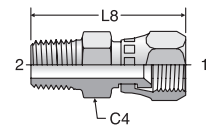

TUBE FITTING PART #	END SIZE		BSPT	C4 (mm)	L8 (mm)	STANDARD Dynamic Pressure (x 1,000 PSI)		
	1	2				-S	-SS	-B
	(mm)	(in.)						
4F63MX	6	1/4	1/8-20	13	34.1	4.5		
4-4F63MX	6	1/4	1/4-19	14	38.1	4.5		
5F63MXS	8	5/16	1/8-20	13	34.1			
5-4F63MX	8	5/16	1/4-19	14	38.4	4.5		
6F63MX	10	3/8	1/4-19	14	40.3	4.5		
6-6F63MX	10	3/8	3/8-19	19	40.6	4.5		
8-4F63MX	12	1/2	1/4-19	19	42.8	4.5		
8F63MX	12	1/2	3/8-19	19	42.8	4.5		
10F63MX	14, 15, 16	5/8	1/2-14	22	51.2	4.5		
12-8F63MX	18, 20	3/4	1/2-14	27	54.6	4.5		
12F63MX	18, 20	3/4	3/4-14	27	54.6	2.3		
16-12F63MX	25	1	3/4-14	32	58.9	2.3		
16F63MX	25	1	1-11	36	63.8	2.3		
20F63MX	28, 30, 32	1 1/4	1 1/4-11	46	69.0	2.3		

Dimensions and pressures for reference only, subject to change.





### WNTX

45° Bulkhead Union Elbow  
37° Flare / 37° Flare

SAE 070801  
HPD Base # 3353  
WNTX-WLN – Body with locknut  
(See [page C15](#) for WLN)

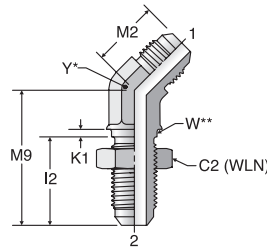

Y\* – Across wrench flats.  
W\*\* – Bulkhead pilot dia.  
recommended clearance hole  
+.015 over W dia.

TUBE FITTING PART #	END SIZE		C2 (in.)	I2 (in.)	K1 (in.)	M2 (in.)	M9 (in.)	W DIA (in.)	MAX BULKHEAD WALL THICKNESS (in.)	Y (in.)	STANDARD Dynamic Pressure (x 1,000 PSI)		
	1 & 2 (in.)	HEX (in.)									-S	-SS	-B
4 WNTX	1/4	11/16	1.02	0.09	0.72	1.53	0.44	0.21	7/16	7.5	7.7		
5 WNTX	5/16	3/4	1.02	0.09	0.78	1.66	0.56	0.21	9/16	7.5			
6 WNTX	3/8	13/16	1.09	0.09	0.83	1.67	0.56	0.28	9/16	7.5	6.0		
8 WNTX	1/2	1	1.25	0.13	0.98	1.94	0.75	0.33	3/4	6.0	6.0		
10 WNTX	5/8	1 1/8	1.39	0.13	1.11	2.17	0.82	0.32	7/8	5.0			
12 WNTX	3/4	1 3/8	1.56	0.13	1.28	2.44	1.06	0.34	1 1/16	5.0	5.0		
16 WNTX	1	1 5/8	1.56	0.13	1.47	2.56	1.31	0.29	1 5/16	4.5	3.5		
20 WNTX	1 1/4	1 7/8	1.61	0.13	1.59	2.65	1.63	0.29	1 5/8	4.0			

### V6X

45° Swivel Nut Elbow  
37° Flare / 37° Swivel

SAE 070321  
HPD Base # 3703

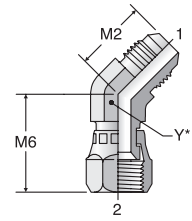

Y\* – Across wrench flats

TUBE FITTING PART #	END SIZE		M2 (in.)	M6 (in.)	Y (in.)	STANDARD Dynamic Pressure (x 1,000 PSI)		
	1 & 2 (in.)					-S	-SS	-B
4 V6X	1/4		0.72	0.94	7/16	7.5	7.7	
5 V6X	5/16		0.77	1.00	9/16	6.0		
6 V6X	3/8		0.83	1.12	9/16	6.0	6.0	
8 V6X	1/2		0.98	1.28	3/4	6.0	6.0	
10 V6X	5/8		1.11	1.44	7/8	5.0	5.0	
12 V6X	3/4		1.28	1.50	1 1/16	5.0	5.0	
14 V6X	7/8		1.39	1.62	1 3/16	5.0		
16 V6X	1		1.47	1.75	1 5/16	4.0	2.5	
20 V6X	1 1/4		1.59	2.03	1 5/8	4.0	2.5	
24 V6X	1 1/2		1.78	2.27	1 7/8	3.0		
32 V6X	2		2.22	2.76	2 1/2	2.0	1.5	

### V50X

45° Straight Thread Elbow  
37° Flare / SAE-ORB

SAE 070320  
HPD Base # 3503

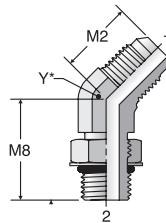

Y\* – Across wrench flats

TUBE FITTING PART #	END SIZE		M2 (in.)	M8 (in.)	Y (in.)	STANDARD Dynamic Pressure (x 1,000 PSI)		
	1 (in.)	2 UN/UNF-2A				-S	-SS	-B
4 V50X	1/4	7/16-20	0.72	1.05	7/16	6.0	6.0	
4-6 V50X	1/4	9/16-18	0.82	1.14	9/16	6.0		
5 V50X	5/16	1/2-20	0.77	1.05	9/16	6.0		
6 V50X	3/8	9/16-18	0.83	1.14	9/16	6.0	5.4	
6-4 V50X	3/8	7/16-20	0.83	1.08	9/16	6.0		
6-8 V50X	3/8	3/4-16	0.86	1.30	3/4	6.0		
8 V50X	1/2	3/4-16	0.98	1.30	3/4	6.0	5.4	
8-6 V50X	1/2	9/16-18	0.98	1.09	3/4	6.0	5.4	
8-10 V50X	1/2	7/8-14	1.00	1.52	7/8	5.0	5.4	
8-12 V50X	1/2	1 1/16-12	1.04	1.73	1 1/16	5.0		
10 V50X	5/8	7/8-14	1.11	1.52	7/8	5.0	5.4	
10-8 V50X	5/8	3/4-16	1.11	1.38	7/8	5.0		
10-12 V50X	5/8	1 1/16-12	1.16	1.73	1 1/16	5.0		
12 V50X	3/4	1 1/16-12	1.28	1.73	1 1/16	5.0	5.4	
12-10 V50X	3/4	7/8-14	1.28	1.58	1 1/16	5.0	5.4	
12-16 V50X	3/4	1 5/16-12	1.42	1.86	1 5/16	4.0		
14 V50X	7/8	1 3/16-12	1.45	1.86	1 5/16	5.0		
16 V50X	1	1 5/16-12	1.47	1.86	1 5/16	4.0	3.0	
16-12 V50X	1	1 1/16-12	1.47	1.86	1 5/16	4.0		
16-20 V50X	1	1 5/8-12	1.55	1.91	1 5/8	4.0		
20 V50X	1 1/4	1 5/8-12	1.59	1.91	1 5/8	4.0	2.5	
20-16 V50X	1 1/4	1 5/16-12	1.59	1.91	1 5/8	4.0		
24 V50X	1 1/2	1 7/8-12	1.78	1.91	1 7/8	3.0		
32 V50X	2	2 1/2-12	2.22	1.86	2 1/2	2.0		

### V870MX

Male 45° Elbow – ISO 6149  
37° Flare / ISO 6149

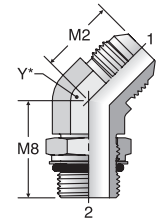

Y\* – Across wrench flats

TUBE FITTING PART #	END SIZE		Male Metric Parallel Thread	M2 (mm)	M8 (mm)	Y (mm)	STANDARD Dynamic Pressure (x 1,000 PSI)		
	1 (mm)	2 (in.)					-S	-SS	-B
	4M12V870MX	6					1/4	M12X1.5	19.6
6M14V870MX	10	3/8	M14X1.5	21.1	28.0	14	6.0		
8M16V870MX	12	1/2	M16 X 1.5	24.9	32.1	19	5.0		
10M22V870MX	14, 15, 16	5/8	M22 X 1.5	28.2	37.2	22	5.0		
12M27V870MX	18, 20	3/4	M27 X 2.0	32.5	43.2	27	5.0		
16M33V870MX	25	1	M33 X 2.0	37.3	46.5	33	4.0		

Dimensions and pressures for reference only, subject to change.



### VTX

45° Male Elbow  
37° Flare / NPTF

SAE 070302  
HPD Base # 3103

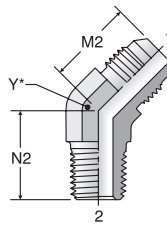

Y\* – Across wrench flats

TUBE FITTING PART #	END SIZE			M2 (in.)	N2 (in.)	Y (in.)	STANDARD Dynamic Pressure (x 1,000 PSI)		
	1 (in.)	2 NPTF					-S	-SS	-B
	2 VTX	1/8	1/8-27				0.69	0.53	7/16
3 VTX	3/16	1/8-27	0.69	0.53	7/16	6.0			
4 VTX	1/4	1/8-27	0.72	0.64	7/16	6.0	6.0	3.3	
4-4 VTX	1/4	1/4-18	0.82	0.86	9/16	6.0	6.0	3.3	
4-6 VTX	1/4	3/8-18	0.92	0.95	3/4	6.0			
5 VTX	5/16	1/8-27	0.77	0.64	9/16	6.0	6.0	3.3	
5-4 VTX	5/16	1/4-18	0.82	0.86	9/16	6.0	6.0		
6 VTX	3/8	1/4-18	0.83	0.86	9/16	6.0	6.0	3.3	
6-2 VTX	3/8	1/8-27	0.83	0.67	9/16	6.0	6.0	3.3	
6-6 VTX	3/8	3/8-18	0.87	0.95	3/4	6.0	6.0	3.3	
6-8 VTX	3/8	1/2-14	1.06	1.17	7/8	6.0	6.0		
8 VTX	1/2	3/8-18	0.98	0.95	3/4	6.0	6.0	3.3	
8-4 VTX	1/2	1/4-18	0.98	0.95	3/4	6.0	6.0		
8-8 VTX	1/2	1/2-14	0.99	1.17	7/8	6.0	6.0	3.3	
8-12 VTX	1/2	3/4-14	1.04	1.20	1 1/16	4.0	4.0		
10 VTX	5/8	1/2-14	1.11	1.17	7/8	5.0	5.0	3.3	
10-6 VTX	5/8	3/8-18	1.11	0.98	7/8	5.0	5.0		
10-12 VTX	5/8	3/4-14	1.28	1.20	1 1/16	4.0			
12 VTX	3/4	3/4-14	1.28	1.20	1 1/16	4.0	4.0	2.6	
12-8 VTX	3/4	1/2-14	1.28	1.20	1 1/16	5.0	5.0		
12-16 VTX	3/4	1-11 1/2	1.42	1.48	1 5/16	3.0			
14 VTX	7/8	3/4-14	1.39	1.27	1 5/16	4.0			
16 VTX	1	1-11 1/2	1.47	1.48	1 5/16	3.0	3.0	2.0	
16-12 VTX	1	3/4-14	1.47	1.29	1 5/16	4.0	4.0		
16-20 VTX	1	1 1/4-11 1/2	1.59	1.67	1 5/8	2.5			
20 VTX	1 1/4	1 1/4-11 1/2	1.59	1.67	1 5/8	2.5	2.5		
20-16 VTX	1 1/4	1-11 1/2	1.59	1.63	1 5/8	3.0			
24 VTX	1 1/2	1 1/2-11 1/2	1.78	1.77	1 7/8	2.5	2.5		
32 VTX	2	2-11 1/2	2.22	2.11	2 1/2	2.0			

### V3MX

Male 45° Elbow – BSPT  
37° Flare / BSPT

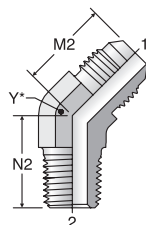

Y\* – Across wrench flats

TUBE FITTING PART #	END SIZE			M2 (mm)	N2 (mm)	Y (mm)	STANDARD Dynamic Pressure (x 1,000 PSI)		
	1 (mm)	(in.)	BSPT				-S	-SS	-B
	4V3MX	6	1/4				1/8-28	18.3	16.3
4-4V3MX	6	1/4	1/4-19	20.8	21.8	14	4.5		
6V3MX	10	3/8	1/4-19	21.1	21.8	14	4.5		
6-6V3MX	10	3/8	3/8-19	22.1	24.1	19	4.5		
8V3MX	12	1/2	3/8-19	24.9	24.1	19	4.5		
8-8V3MX	12	1/2	1/2-14	25.2	29.7	22	4.5		
12V3MX	18, 20	3/4	3/4-14	32.5	30.5	27	2.3		

### V40MX

Male 45° Elbow – BSPP  
37° Flare / BSPP-ORR

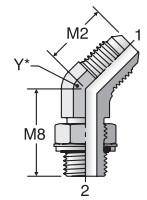

Y\* – Across wrench flats

TUBE FITTING PART #	END SIZE			M2 (mm)	M8 (mm)	Y (mm)	STANDARD Dynamic Pressure (x 1,000 PSI)		
	1 (mm)	(in.)	BSPP				-S	-SS	-B
	4V40MX	6	1/4				1/8-28	18.3	26.7
6V40MX	10	3/8	1/4-19	21.1	29.0	14	3.6		
8V40MX	12	1/2	3/8-19	24.9	33.0	19	3.6		
10V40MX	14, 15, 16	5/8	1/2-14	28.2	38.6	22	3.6		
12V40MX	18, 20	3/4	3/4-14	32.5	43.9	27	3.6		
16V40MX	25	1	1-11	37.2	47.2	33	3.6		

### ETX

Union Elbow  
37° Flare / 37° Flare

SAE 070201  
HPD Base # 2303

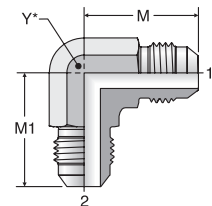

Y\* – Across wrench flats

TUBE FITTING PART #	END SIZE			M (in.)	M1 (in.)	Y (in.)	STANDARD Dynamic Pressure (x 1,000 PSI)		
	1 (in.)	2 (in.)					-S	-SS	-B
	2 ETX	1/8	1/8				0.78	0.78	7/16
3 ETX	3/16	3/16	0.83	0.83	7/16				
4 ETX	1/4	1/4	0.89	0.89	7/16	7.5	7.7	3.3	
5 ETX	5/16	5/16	0.95	0.95	9/16	6.0	6.0	3.3	
6 ETX	3/8	3/8	1.06	1.06	9/16	6.0	6.0	3.3	
6-4 ETX	3/8	1/4	1.06	1.05	9/16	6.0			
8 ETX	1/2	1/2	1.25	1.25	3/4	6.0	6.0	3.3	
8-6 ETX	1/2	3/8	1.25	1.14	3/4	6.0			
10 ETX	5/8	5/8	1.45	1.45	7/8	5.0	5.0	3.3	
10-8 ETX	5/8	1/2	1.45	1.33	7/8	5.0			
12 ETX	3/4	3/4	1.66	1.66	1 1/16	5.0	5.0	3.3	
12-8 ETX	3/4	1/2	1.66	1.42	1 1/16				
12-10 ETX	3/4	5/8	1.66	1.54	1 1/16		5.0		
14 ETX	7/8	7/8	1.73	1.73	1 3/16	5.0			
16 ETX	1	1	1.81	1.81	1 5/16	4.0	3.5	2.3	
16-12 ETX	1 to 3/4	3/4	1.81	1.77	1 5/16				
20 ETX	1 1/4	1 1/4	2.06	2.06	1 5/8	4.0	3.0		
24 ETX	1 1/2	1 1/2	2.33	2.33	1 7/8	3.0	2.0		
32 ETX	2	2	3.06	3.06	2 1/2	2.0	1.5		

Dimensions and pressures for reference only, subject to change.

# WETX

Bulkhead Union Elbow  
37° Flare / 37° Flare

SAE 070701  
HPD Base # 2353  
WETX-WLN – Body with locknut  
(See [page C15](#) for WLN)

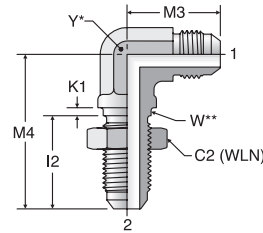

Y\* – Across wrench flats.  
W\*\* – Bulkhead pilot dia.  
recommended clearance hole  
+.015 over W dia.

TUBE FITTING PART #	END SIZE		I2 (in.)	K1 (in.)	M3 (in.)	M4 (in.)	W DIA (in.)	MAX BULKHEAD WALL THICKNESS (in.)	Y (in.)	STANDARD Dynamic Pressure (x 1,000 PSI)		
	1 & 2 (in.)	C2 HEX (in.)								-S	-SS	-B
3 WETX	3/16	5/8	0.92	0.09	0.94	1.50	0.38	0.21	7/16		7.7	
4 WETX	1/4	11/16	1.20	0.09	0.97	1.59	0.44	0.21	7/16	7.5	7.7	3.3
5 WETX	5/16	3/4	1.02	0.09	1.06	1.72	0.50	0.21	9/16	6.0		
6 WETX	3/8	13/16	1.09	0.09	1.09	1.81	0.56	0.28	9/16	6.0	6.0	3.3
8 WETX	1/2	1	1.25	0.13	1.36	2.11	0.75	0.33	3/4	6.0	6.0	3.3
10 WETX	5/8	1 1/8	1.39	0.13	1.56	2.39	0.88	0.32	7/8	5.0	5.0	
12 WETX	3/4	1 3/8	1.56	0.13	1.78	2.67	1.06	0.34	1 1/16	5.0	5.0	
14 WETX	7/8	1 1/2	1.56	0.13	1.92	2.80	1.19	0.31	1 5/8	5.0		
16 WETX	1	1 5/8	1.56	0.13	1.94	2.80	1.31	0.29	1 5/8	4.0	3.5	
20 WETX	1 1/4	1 7/8	1.61	0.13	2.17	3.13	1.63	0.29	1 5/8	4.0		

# C6X

Swivel Nut Elbow  
37° Flare / 37° Swivel

SAE 070221  
HPD Base # 3903

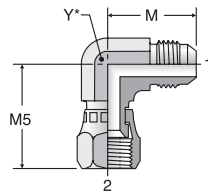

Y\* – Across wrench flats

TUBE FITTING PART #	END SIZE		M (in.)	M5 (in.)	Y (in.)	STANDARD Dynamic Pressure (x 1,000 PSI)		
	1 (in.)	2 (in.)				-S	-SS	-B
3 C6X	3/16	3/16	0.83	1.00	7/16	7.5	7.7	
4 C6X	1/4	1/4	0.89	1.00	7/16	7.5	7.7	
5 C6X	5/16	5/16	0.95	1.06	9/16	6.0	6.0	
6 C6X	3/8	3/8	1.06	1.25	9/16	6.0	6.0	
8 C6X	1/2	1/2	1.25	1.38	3/4	6.0	6.0	
10 C6X	5/8	5/8	1.45	1.62	7/8	5.0	5.0	
12 C6X	3/4	3/4	1.66	1.75	1 1/16	5.0	5.0	
12-24 C6X	3/4	1 1/2	2.11	2.59	1 7/8			
14 C6X	7/8	7/8	1.80	1.78	1 5/16	5.0		
16 C6X	1	1	1.81	2.00	1 5/16	4.0	2.5	
16-12 C6X	1	3/4	1.81	1.87	1 5/16			
20 C6X	1 1/4	1 1/4	2.06	2.31	1 5/8	4.0	2.5	
24 C6X	1 1/2	1 1/2	2.33	2.59	1 7/8	3.0	2.0	
32 C6X	2	2	3.06	3.51	2 1/2	2.0	1.5	

# AOEX6

Swivel Elbow Straight  
Thread Connector  
SAE-ORB / 37° Swivel

HPD Base # 2506

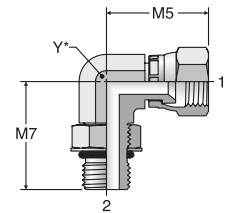

Y\* – Across wrench flats

TUBE FITTING PART #	END SIZE		M5 (in.)	M7 (in.)	Y (in.)	STANDARD Dynamic Pressure (x 1,000 PSI)		
	1 (in.)	2 UN/UNF-2A				-S	-SS	-B
4 AOEX6	1/4	7/16-20	0.94	1.03	7/16	6.0		
6 AOEX6	3/8	9/16-18	1.27	1.25	9/16	6.0		
8 AOEX6	1/2	3/4-16	1.34	1.45	3/4	6.0		
10 AOEX6	5/8	7/8-14	1.62	1.70	7/8	5.0		
12 AOEX6	3/4	1 1/16-12	1.75	1.94	1 1/16	5.0		
16 AOEX6	1	1 5/16-12	2.01	2.05	1 5/16	4.0		

Dimensions and pressures for reference only, subject to change.

### X6EF

Swivel Elbow Connector  
37° Swivel / NPTF

HPD Base # 2106

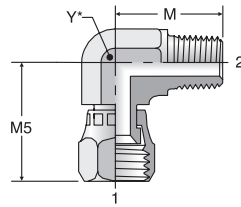

Y\* – Across wrench flats

TUBE FITTING PART #	END SIZE		M (in.)	M5 (in.)	Y (in.)	STANDARD Dynamic Pressure (x 1,000 PSI)		
	1 (in.)	2 NPTF				-S	-SS	-B
4 X6EF	1/4	1/8-27	0.78	1.01	7/16	6.0	6.0	
4-4 X6EF	1/4	1/4-18	1.09	1.13	9/16	6.0	6.0	
6 X6EF	3/8	1/4-18	1.09	1.27	9/16	5.0	5.0	
6-6 X6EF	3/8	3/8-18	1.22	1.27	3/4	5.0	5.0	
8 X6EF	1/2	3/8-18	1.22	1.34	3/4	5.0	5.0	
8-8 X6EF	1/2	1/2-14	1.47	1.48	7/8	5.0	5.0	
10 X6EF	5/8	1/2-14	1.47	1.62	7/8	5.0		
12 X6EF	3/4	3/4-14	1.59	1.75	1 1/16	4.0	4.0	
16 X6EF	1	1-11	1.97	2.01	1 5/16	3.0	3.0	

### C50X

Straight Thread Elbow  
37° Flare / SAE-ORB

SAE 070220

HPD Base # 2503

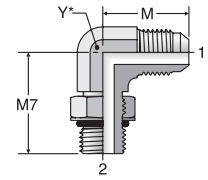

Y\* – Across wrench flats

TUBE FITTING PART #	END SIZE		M (in.)	M7 (in.)	Y (in.)	STANDARD Dynamic Pressure (x 1,000 PSI)		
	1 (in.)	2 UN/UNF-2A				-S	-SS	-B
2 C50X	1/8	5/16-24	0.77	0.94	7/16	5.0	6.0	
3 C50X	3/16	3/8-24	0.83	0.94	7/16	5.0	6.0	
4 C50X	1/4	7/16-20	0.89	1.03	7/16	6.0	6.0	
4-2 C50X	1/4	5/16-24	0.89	0.92	7/16	5.0		
4-6 C50X	1/4	9/16-18	1.05	1.25	9/16	6.0	5.4	
4-8 C50X	1/4	3/4-16	1.13	1.45	3/4	6.0	5.4	
5 C50X	5/16	1/2-20	0.95	1.13	9/16	6.0	5.4	
5-4 C50X	5/16	7/16-18	0.95	1.13	9/16	6.0		
5-6 C50X	5/16	9/16-18	1.06	1.25	9/16	6.0		
6 C50X	3/8	9/16-18	1.06	1.25	9/16	6.0	5.4	
6-4 C50X	3/8	7/16-20	1.06	1.19	9/16	6.0	5.4	
6-5 C50X	3/8	1/2-20	1.06	1.19	9/16	6.0		
6-8 C50X	3/8	3/4-16	1.14	1.45	3/4	6.0	5.4	
6-10 C50X	3/8	7/8-14	1.23	1.70	7/8	5.0		
8 C50X	1/2	3/4-16	1.25	1.45	3/4	6.0	5.4	
8-4 C50X	1/2	7/16-20	1.25	1.26	3/4	6.0	5.4	
8-6 C50X	1/2	9/16-18	1.25	1.34	3/4	6.0	5.4	
8-10 C50X	1/2	7/8-14	1.34	1.70	7/8	5.0	5.4	
8-12 C50X	1/2	1 1/16-12	1.42	1.94	1 1/16	5.0	5.4	
8-16 C50X	1/2	1 5/16-12	1.52	2.05	1 5/16	4.0	3.0	
10 C50X	5/8	7/8-14	1.45	1.70	7/8	5.0	5.4	
10-6 C50X	5/8	9/16-18	1.45	1.41	7/8	5.0		
10-8 C50X	5/8	3/4-16	1.45	1.55	7/8	5.0	5.4	
10-12 C50X	5/8	1 1/16-12	1.53	1.94	1 1/16	5.0		
10-16 C50X	5/8	1 5/16-12	1.64	2.05	1 5/16	4.0		
12 C50X	3/4	1 1/16-12	1.66	1.94	1 1/16	5.0	5.4	
12-8 C50X	3/4	3/4-16	1.66	1.63	1 1/16	5.0	5.4	
12-10 C50X	3/4	7/8-14	1.66	1.78	1 1/16	5.0	5.4	
12-14 C50X	3/4	1 3/16-12	1.77	2.00	1 5/16	5.0		
12-16 C50X	3/4	1 5/16-12	1.81	2.05	1 5/16	4.0	3.0	
12-20 C50X	3/4	1 5/8-12	1.97	2.25	1 5/8	4.0		
14 C50X	7/8	1 3/16-12	1.73	2.00	1 5/16	5.0		
16 C50X	1	1 5/16-12	1.81	2.05	1 5/16	4.0	3.0	
16-12 C50X	1	1 1/16-12	1.81	2.05	1 5/16	4.0	3.0	
16-14 C50X	1	1 3/16-12	1.81	2.07	1 5/16	4.0		
16-20 C50X	1	1 5/8-12	2.01	2.25	1 5/8	4.0	2.5	
16-24 C50X	1	1 7/8-12	2.16	2.39	1 7/8	3.0		
20 C50X	1 1/4	1 5/8-12	2.06	2.25	1 5/8	4.0	2.5	
20-16 C50X	1 1/4	1 5/16-12	2.06	2.25	1 5/8	4.0	2.5	
20-24 C50X	1 1/4	1 7/8-12	2.20	2.39	1 7/8	3.0		
24 C50X	1 1/2	1 7/8-12	2.33	2.39	1 7/8	3.0	2.0	
24-20 C50X	1 1/2	1 5/8-12	2.33	2.39	1 7/8	3.0	2.0	
32 C50X	2	2 1/2-12	3.06	2.89	2 1/2	2.0	1.5	
32-24 C50X	2	1 7/8-12	3.06	2.89	2 1/2			

### CC50X

Long Straight Thread Elbow  
37° Flare / SAE-ORB

SAE 071520

HPD Base # 5503

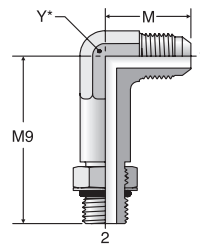

Y\* – Across wrench flats

TUBE FITTING PART #	END SIZE		M (in.)	M9 (in.)	Y (in.)	STANDARD Dynamic Pressure (x 1,000 PSI)		
	1 (in.)	2 UN/UNF-2A				-S	-SS	-B
4 CC50X	1/4	7/16-20	0.89	1.73	9/16	6.0		
6 CC50X	3/8	9/16-18	1.06	2.08	9/16	6.0		
8 CC50X	1/2	3/4-16	1.25	2.50	7/8	6.0		
10 CC50X	5/8	7/8-14	1.45	2.89	7/8	5.0		
12 CC50X	3/4	1 1/16-12	1.66	3.34	1 1/16	5.0		
16 CC50X	1	1 5/16-12	1.81	3.72	1 5/16	4.0		

Dimensions and pressures for reference only, subject to change.

### CTX

Male Elbow  
37° Flare / NPTF

SAE 070202  
HPD Base # 2103

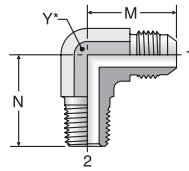

Y\* – Across wrench flats

### CCTX

Long Male Elbow  
37° Flare / NPTF

SAE 071502  
HPD Base # 5603

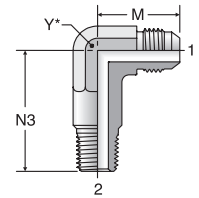

Y\* – Across wrench flats

TUBE FITTING PART #	END SIZE		M (in.)	N (in.)	Y (in.)	STANDARD Dynamic Pressure (x 1,000 PSI)		
	1 (in.)	2 NPTF				-S	-SS	-B
2 CTX	1/8	1/8-27	0.77	0.72	5/16	6.0	6.0	3.3
3 CTX	3/16	1/8-27	0.83	0.72	3/8	6.0	6.0	3.3
4 CTX	1/4	1/8-27	0.89	0.78	7/16	6.0	6.0	3.3
4-4 CTX	1/4	1/4-18	1.05	1.09	9/16	6.0	6.0	3.3
4-6 CTX	1/4	3/8-18	1.13	1.22	3/4	6.0	6.0	
4-8 CTX	1/4	1/2-14	1.23	1.44	7/8	6.0	6.0	
5 CTX	5/16	1/8-27	0.95	0.78	9/16	6.0	6.0	3.3
5-4 CTX	5/16	1/4-18	1.05	1.09	9/16	6.0	6.0	3.3
5-6 CTX	5/16	3/8-18	1.13	1.22	3/4	6.0	6.0	
6 CTX	3/8	1/4-18	1.06	1.09	9/16	6.0	6.0	3.3
6-2 CTX	3/8	1/8-27	1.06	0.90	9/16	6.0	6.0	3.3
6-6 CTX	3/8	3/8-18	1.14	1.22	3/4	6.0	6.0	3.3
6-8 CTX	3/8	1/2-14	1.22	1.47	7/8	6.0	6.0	3.3
6-12 CTX	3/8	3/4-14	1.31	1.59	1 1/16	4.0	4.0	
8 CTX	1/2	3/8-18	1.25	1.22	3/4	6.0	6.0	3.3
8-4 CTX	1/2	1/4-18	1.25	1.22	3/4	6.0	6.0	3.3
8-8 CTX	1/2	1/2-14	1.33	1.47	7/8	6.0	6.0	3.3
8-12 CTX	1/2	3/4-14	1.42	1.59	1 1/16	4.0	4.0	2.6
8-16 CTX	1/2	1-11 1/2	1.52	1.97	1 5/16	3.0	3.0	
10 CTX	5/8	1/2-14	1.45	1.47	7/8	5.0	5.0	3.3
10-6 CTX	5/8	3/8-18	1.45	1.28	7/8	5.0	5.0	3.3
10-12 CTX	5/8	3/4-14	1.53	1.59	1 1/16	4.0	4.0	
10-16 CTX	5/8	1-11 1/2	1.64	1.97	1 5/16	3.0		
12 CTX	3/4	3/4-14	1.66	1.59	1 1/16	4.0	4.0	2.6
12-6 CTX	3/4	3/8-18	1.66	1.41	1 1/16	5.0	5.0	
12-8 CTX	3/4	1/2-14	1.66	1.59	1 1/16	5.0	5.0	2.9
12-16 CTX	3/4	1-11 1/2	1.76	1.97	1 5/16	3.0	3.0	
14 CTX	7/8	3/4-14	1.80	1.69	1 5/16	4.0		2.3
16 CTX	1	1-11 1/2	1.81	1.97	1 5/16	3.0	3.0	2.0
16-8 CTX	1	1/2-14	1.81	1.66	1 5/16	4.0		
16-12 CTX	1	3/4-14	1.81	1.78	1 5/16	4.0	4.0	2.3
16-20 CTX	1	1 1/4-11 1/2	2.13	2.38	1 5/8	2.5	2.5	
20 CTX	1 1/4	1 1/4-11 1/2	2.06	2.38	1 5/8	2.5	2.5	1.6
20-16 CTX	1 1/4	1-11 1/2	2.06	2.06	1 5/8	3.0	3.0	
20-24 CTX	1 1/4	1 1/2-11 1/2	2.20	2.64	1 7/8	2.5		
24 CTX	1 1/2	1 1/2-11 1/2	2.33	2.64	1 7/8	2.5	2.5	
24-20 CTX	1 1/2	1 1/4-11 1/2	2.33	2.25	1 7/8	2.5	2.5	
24-32 CTX	1 1/2	2-11 1/2	2.81	3.00	2 1/2	2.0		
32 CTX	2	2-11 1/2	3.06	3.00	2 1/2	2.0	2.0	
32-24 CTX	2	1 1/2-11 1/2	3.06	2.97	2 1/2	2.0		
40 CTX	2 1/2	2 1/2-8	2.86	3.57	3 1/4			

TUBE FITTING PART #	END SIZE		M (in.)	N3 (in.)	Y (in.)	STANDARD Dynamic Pressure (x 1,000 PSI)		
	1 (in.)	2 NPTF				-S	-SS	-B
4 CCTX	1/4	1/8-27	0.89	1.19	7/16	6.0	6.0	3.3
4-4 CCTX	1/4	1/4-18	1.05	1.44	9/16	6.0	6.0	
5 CCTX	5/16	1/8-27	0.95	1.17	9/16	6.0		
6 CCTX	3/8	1/4-18	1.06	1.56	9/16	6.0	6.0	3.3
6-6 CCTX	3/8	3/8-18	1.14	1.81	3/4	6.0	6.0	
8 CCTX	1/2	3/8-18	1.25	1.78	3/4	6.0		
8-8 CCTX	1/2	1/2-14	1.34	2.16	7/8	6.0	6.0	
8-12 CCTX	1/2	3/4-14	1.42	2.44	1 1/16	4.0		
10 CCTX	5/8	1/2-14	1.45	2.16	7/8	5.0	5.0	
12 CCTX	3/4	3/4-14	1.66	2.41	1 1/16	4.0	4.0	
14 CCTX	7/8	3/4-14	1.80	2.59	1 5/16			
16 CCTX	1	1-11 1/2	1.81	2.97	1 5/16	3.0	3.0	
20 CCTX	1 1/4	1 1/4-11 1/2	2.06	3.66	1 5/8	2.5	2.5	

### CCCTX

Extra Long Male Elbow  
37° Flare / NPTF

SAE 071602  
HPD Base # 5703

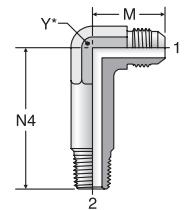

Y\* – Across wrench flats

TUBE FITTING PART #	END SIZE		M (in.)	N4 (in.)	Y (in.)	STANDARD Dynamic Pressure (x 1,000 PSI)		
	1 (in.)	2 NPTF				-S	-SS	-B
4 CCCTX	1/4	1/8-27	0.89	1.56	7/16	6.0		3.3
4-4 CCCTX	1/4	1/4-18	1.05	2.03	9/16	6.0		
5 CCCTX	5/16	1/8-27	0.97	1.63	9/16	6.0		
6 CCCTX	3/8	1/4-18	1.06	2.07	9/16	6.0		3.3
6-6 CCCTX	3/8	3/8-18	1.14	2.34	3/4	6.0		
8 CCCTX	1/2	3/8-18	1.25	2.34	3/4	6.0		
8-8 CCTX	1/2	1/2-14	1.34	2.84	7/8	6.0	6.0	
10 CCCTX	5/8	1/2-14	1.45	2.84	7/8	5.0		
12 CCCTX	3/4	3/4-14	1.66	3.22	1 1/16	4.0		
16 CCCTX	1	1-11 1/2	1.81	3.97	1 5/16	3.0		
20 CCCTX	1 1/4	1 1/4-11 1/2	2.06	4.94	1 5/8			

Dimensions and pressures for reference only, subject to change.

### DTX

Female Elbow  
37° Flare / NPTF

SAE 070203  
HPD Base # 2203

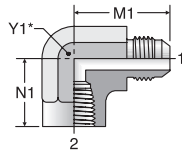

Y\* – Across wrench flats

### C870MX

Male Elbow – ISO 6149  
37° Flare / ISO 6149

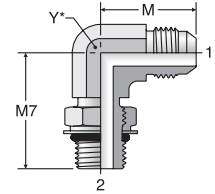

Y\* – Across wrench flats

TUBE FITTING PART #	END SIZE		M1 (in.)	N1 (in.)	Y1 (in.)	STANDARD Dynamic Pressure (x 1,000 PSI)		
	1 (in.)	2 NPTF				-S	-SS	-B
	4 DTX	1/4						
4-4 DTX	1/4	1/4-18	1.22	0.88	3/4	5.0	5.0	3.3
5 DTX	5/16	1/8-27	1.08	0.66	9/16	5.0		3.3
5-4 DTX	5/16	1/4-18	1.13	0.88	3/4	5.0	5.0	
6 DTX	3/8	1/4-18	1.23	0.88	3/4	5.0	5.0	3.3
6-2 DTX	3/8	1/8-27	1.23	0.67	9/16	5.0		
6-6 DTX	3/8	3/8-18	1.31	1.02	7/8	4.5	4.5	2.9
8 DTX	1/2	3/8-18	1.42	1.02	7/8	4.5	4.5	2.0
8-4 DTX	1/2	1/4-18	1.42	1.01	3/4	4.5	4.5	3.3
8-8 DTX	1/2	1/2-14	1.52	1.23	1 1/16	3.0	3.0	2.0
10 DTX	5/8	1/2-14	1.64	1.23	1 1/16	3.0	3.0	2.0
12 DTX	3/4	3/4-14	1.89	1.36	1 5/16	3.0	3.0	2.0
12-8 DTX	3/4	1/2-14	1.89	1.35	1 1/16	3.0	3.0	
14 DTX	7/8	3/4-14	1.86	1.42	1 5/16	3.0		
16 DTX	1	1-11 1/2	2.17	1.63	1 5/8	1.8	1.8	
20 DTX	1 1/4	1 1/4-11 1/2	2.33	1.70	1 7/8	1.5	1.5	
24 DTX	1 1/2	1 1/2-11 1/2	2.89	2.08	2 1/2	1.5	1.5	

TUBE FITTING PART #	END SIZE		M (mm)	M7 (mm)	Y (mm)	STANDARD Dynamic Pressure (x 1,000 PSI)			
	1 (mm)	2				-S	-SS	-B	
	(mm)	Male Metric Parallel Thread (in.)							
4M10C870MX	6	1/4	M10x1	22.6	25.0	11	6.0		
5M12C870MX	8	5/16	M12x1.5	24.1	30.0	13	6.0		
6M14C870MX	10	3/8	M14x1.5	26.9	34.9	14	6.0		
8M16C870MX	12	1/2	M16x1.5	31.8	35.9	19	5.0		
8M18C870MX	12	1/2	M18x1.5	31.8	36.8	19	5.0		
10M18C870MX	14, 15, 16	5/8	M18x1.5	36.8	40.7	22	5.0		
10M22C870MX	14, 15, 16	5/8	M22x1.5	36.8	41.7	22	5.0		
12M22C870MX	18, 20	3/4	M22x.15	42.2	44.4	27	5.0		
12M27C870MX	18, 20	3/4	M27x2	42.2	48.5	27	5.0		
16M33C870MX	25	1	M33x2	46.0	51.2	33	4.0		

### C80MX

Male Elbow – Metric-ORR  
37° Flare / Metric-ORR

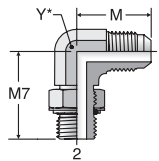

Y\* – Across wrench flats

TUBE FITTING PART #	END SIZE		Male Metric Parallel Thread	M (mm)	M7 (mm)	Y (mm)	STANDARD Dynamic Pressure (x 1,000 PSI)		
	1 (mm)	2 (in.)					-S	-SS	-B
	4M10C80MX	6							
5M12C80MX	8	5/16	M12x1.5	24.1	28.5	13	3.6		
6M14C80MX	10	3/8	M14x1.5	26.9	32.5	14	3.6		
8M16C80MX	12	1/2	M16x1.5	31.8	36.4	19	3.6		
8M18C80MX	12	1/2	M18x1.5	31.8	36.8	19	3.6		
10M18C80MX	14, 15, 16	5/8	M18x1.5	36.8	41.0	22	3.6		
10M22C80MX	14, 15, 16	5/8	M22x1.5	36.8	42.5	22	3.6		
12M22C80MX	18, 20	3/4	M22x.15	42.2	44.0	27	3.6		
12M27C80MX	18, 20	3/4	M27x2.0	42.2	50.0	27	2.5		
16M33C80MX	25	1	M33x2.0	46.0	53.0	33	2.0		

Dimensions and pressures for reference only, subject to change.

### C40MX

Male Elbow – BSPP  
37° Flare / BSPP-ORR

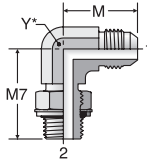

Y\* – Across wrench flats

### C3MX

Male Elbow – BSPT  
37° Flare / BSPT

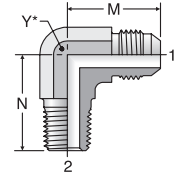

Y\* – Across wrench flats

TUBE FITTING PART #	END SIZE			M (mm)	M7 (mm)	Y (mm)	STANDARD Dynamic Pressure (x 1,000 PSI)		
	1		2				-S	-SS	-B
	(mm)	(in.)	BSPP						
4C40MX	6	1/4	1/8-28	22.6	26.2	11	3.6		
4-4C40MX	6	1/4	1/4-19	22.6	31.8	14	3.6		
5C40MX	8	5/16	1/8-28	24.1	27.7	13	3.6		
5-4C40MX	8	5/16	1/4-19	26.6	31.8	14	3.6		
5-6C40MX	8	5/16	3/8-19	28.5	36.8	19	3.6		
6C40MX	10	3/8	1/4-19	26.9	31.8	14	3.6		
6-6C40MX	10	3/8	3/8-19	29.0	36.8	19	3.6	3.6	
8-4C40MX	12	1/2	1/4-19	31.8	36.8	19	3.6		
8C40MX	12	1/2	3/8-19	31.8	36.8	19	3.6		
8-8C40MX	12	1/2	1/2-14	33.8	43.2	22	3.6		
10-6C40MX	16	5/8	3/8-19	36.8	37.1	22	3.6		
10C40MX	14,15,16	5/8	1/2-14	36.8	43.2	22	3.6		
10-12C40MX	15	5/8	3/4-14	39.2	49.3	27	3.6		
12-8C40MX	18,20	3/4	1/2-14	42.2	49.3	27	3.6		
12C40MX	18,20	3/4	3/4-14	42.2	49.3	27	3.6		
12-16C40MX	18	3/4	1-11	44.7	52.1	33	3.6		
16-12C40MX	25	1	3/4-14	46.0	48.2	33	3.6		
16C40MX	25	1	1-11	46.0	52.1	33	3.6		
20-16C40MX	30,32	1 1/4	1-11	52.3	57.2	41	3.6		
20C40MX	30,32	1 1/4	1 1/4-11	52.3	57.2	41	3.0		
24-20C40MX	38	1 1/2	1 1/4-11	59.2	60.7	48	3.0		
24C40MX	38	1 1/2	1 1/2-11	59.2	60.7	48	2.0		

TUBE FITTING PART #	END SIZE			M (mm)	N (mm)	Y (mm)	STANDARD Dynamic Pressure (x 1,000 PSI)		
	1		2				-S	-SS	-B
	(mm)	(in.)	BSPT						
4C3MX	6	1/4	1/8-28	22.6	19.8	11	4.5		
4-4C3MX	6	1/4	1/4-19	26.6	27.7	14	4.5		
5C3MX	8	5/16	1/8-28	24.1	19.8	13	4.5		
5-4C3MX	8	5/16	1/4-19	26.6	27.7	14	4.5		
6C3MX	10	3/8	1/4-19	26.9	27.7	14	4.5		
6-6C3MX	10	3/8	3/8-19	29.0	31.0	19	4.5		
6-8C3MX	10	3/8	1/2-14	31.0	37.3	22	4.5		
8-4C3MX	12	1/2	1/4-19	31.8	31.0	19	4.5		
8C3MX	12	1/2	3/8-19	31.8	31.0	19	4.5		
8-8C3MX	12	1/2	1/2-14	33.8	37.3	22	4.5		
10-6C3MX	14,15,16	5/8	3/8-19	36.5	32.5	22	4.5		
10C3MX	14,15,16	5/8	1/2-14	36.8	37.3	22	4.5		
10-12C3MX	14,15,16	5/8	3/4-14	39.2	40.4	27	2.3		
12-8C3MX	18,20	3/4	1/2-14	42.2	40.4	27	4.5		
12C3MX	18,20	3/4	3/4-14	42.2	40.4	27	2.3		
16-12C3MX	25	1	3/4-14	46.0	45.2	33	2.3		
16C3MX	25	1	1-11	46.0	50.0	33	2.3		
20-16C3MX	30,32	1 1/4	1-11	52.3	59.7	41	2.3		
20C3MX	30,32	1 1/4	1 1/4-11	52.3	60.5	41	2.3		
24C3MX	38	1 1/2	1 1/2-11	59.2	67.1	48	2.3		

### JTX

Union Tee  
37° Flare (all three ends)

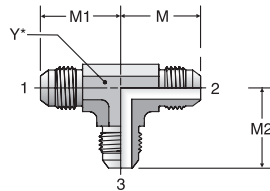

Y\* – Across wrench flats

SAE 070401  
HPD Base # 033T

TUBE FITTING PART #	END SIZE			M (in.)	M1 (in.)	M2 (in.)	Y (in.)	STANDARD Dynamic Pressure (x 1,000 PSI)		
	1 (in.)	2 (in.)	3 (in.)					-S	-SS	-B
	2 JTX	1/8	1/8							
3 JTX	3/16	3/16	3/16	0.83	0.83	0.83	7/16	7.5	7.7	
4 JTX	1/4	1/4	1/4	0.89	0.89	0.89	7/16	7.5	7.7	3.3
4-4-3 JTX	1/4	1/4	3/16	0.89	0.89	0.81	7/16			
5 JTX	5/16	5/16	5/16	0.95	0.95	0.95	9/16	6.0	6.0	3.3
6 JTX	3/8	3/8	3/8	1.06	1.06	1.06	9/16	6.0	6.0	3.3
8 JTX	1/2	1/2	1/2	1.25	1.25	1.25	3/4	6.0	6.0	3.3
10 JTX	5/8	5/8	5/8	1.45	1.45	1.45	7/8	5.0	5.0	3.3
12 JTX	3/4	3/4	3/4	1.66	1.66	1.66	1 1/16	5.0	5.0	2.9
12-12-8 JTX	3/4	3/4	1/2	1.66	1.66	1.42	1 1/16		5.0	
12-16-12 JTX	3/4	1	3/4	1.77	1.81	1.77	1 5/16			
14 JTX	7/8	7/8	7/8	1.73	1.73	1.73	1 5/16	5.0		
16 JTX	1	1	1	1.81	1.81	1.81	1 5/16	4.0	3.5	2.3
20 JTX	1 1/4	1 1/4	1 1/4	2.06	2.06	2.06	1 5/8	4.0	3.0	
24 JTX	1 1/2	1 1/2	1 1/2	2.33	2.33	2.33	1 7/8	3.0	2.0	
24-16-16 JTX	1 1/2	1	1	2.33	2.16	2.16	1 7/8			
32 JTX	2	2	2	3.06	3.06	3.06	2 1/2	2.0	1.5	

Dimensions and pressures for reference only, subject to change.



# WJTX

Bulkhead Branch Tee  
37° Flare (all three ends)

SAE 070959  
HPD Base # 543T  
WJTX-WLN – Body with locknut  
(See [page C15](#) for WLN)

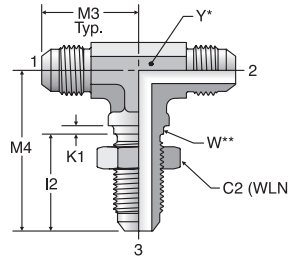

Y\* – Across wrench flats.  
W\*\* – Bulkhead pilot dia.  
recommended clearance hole  
+.015 over W dia.

TUBE FITTING PART #	END SIZE (in.)	C2 HEX (in.)	I2 (in.)	K1 (in.)	M3 (in.)	M4 (in.)	W DIA (in.)	MAX BULKHEAD WALL THICKNESS (in.)	Y (in.)	STANDARD Dynamic Pressure (x 1,000 PSI)		
										-S	-SS	-B
4 WJTX	1/4	11/16	1.02	0.09	0.97	1.59	0.44	0.21	7/16	7.5	7.7	
6 WJTX	3/8	13/16	1.09	0.09	1.09	1.81	0.56	0.28	9/16	6.0	6.0	
8 WJTX	1/2	1	1.25	0.13	1.36	2.11	0.75	0.33	3/4	6.0	6.0	
10 WJTX	5/8	1 1/8	1.39	0.13	1.56	2.39	0.88	0.32	1 1/16	5.0		
12 WJTX	3/4	1 3/8	1.56	0.13	1.78	2.67	1.06	0.34	1 1/16	5.0	5.0	
16 WJTX	1	1 5/8	1.56	0.13	1.94	2.80	1.31	0.29	1 5/16	4.0		
20 WJTX***	1 1/4	1 7/8	1.61	0.13	2.17	3.12	1.63	0.29	1 5/8			

\*\*\*Machined from one-piece milled bar stock.

# WJJTX

Bulkhead Run Tee  
37° Flare (all three ends)

SAE 070958  
HPD Base # 533T  
WJJTX-WLN – Body with locknut  
(See [page C15](#) for WLN)

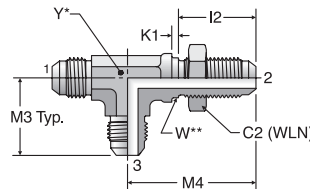

Y\* – Across wrench flats.  
W\*\* – Bulkhead pilot dia.  
recommended clearance hole  
+.015 over W dia.

TUBE FITTING PART #	END SIZE (in.)	C2 HEX (in.)	I2 (in.)	K1 (in.)	M3 (in.)	M4 (in.)	W DIA (in.)	MAX BULKHEAD WALL THICKNESS (in.)	Y (in.)	STANDARD Dynamic Pressure (x 1,000 PSI)		
										-S	-SS	-B
4 WJJTX	1/4	11/16	1.02	0.09	0.97	1.59	0.44	0.21	7/16	7.5	7.7	
6 WJJTX	3/8	13/16	1.09	0.09	1.09	1.81	0.56	0.28	9/16	6.0	6.0	
8 WJJTX	1/2	1	1.25	0.13	1.36	2.11	0.75	0.33	3/4	6.0	6.0	
10 WJJTX	5/8	1 1/8	1.39	0.13	1.56	2.39	0.88	0.32	7/8	5.0		
12 WJJTX	3/4	1 3/8	1.56	0.13	1.78	2.67	1.06	0.34	1 1/16	5.0	5.0	
16 WJJTX***	1	1 5/8	1.56	0.13	1.94	2.80	1.31	0.29	1 7/16			
20 WJJTX***	1 1/4	1 7/8	1.61	0.13	2.17	3.12	1.63	0.29	1 5/8			

\*\*\*Machined from one-piece milled bar stock.

Dimensions and pressures for reference only, subject to change.



### JX6

Swivel Nut Union Tee  
37° Swivel (all three ends)

HPD Base # 069T

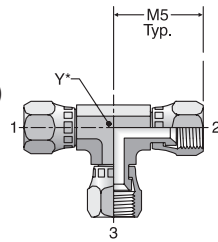

Y\* – Across wrench flats

TUBE FITTING PART #	END SIZE (in.)	M5 (in.)	Y (in.)	STANDARD Dynamic Pressure (x 1,000 PSI)		
				-S	-SS	-B
4 JX6	1/4	1.00	7/16	7.5		
6 JX6	3/8	1.25	9/16	6.0		
8 JX6	1/2	1.38	3/4	6.0		
10 JX6	5/8	1.62	3/4	5.0		
12 JX6	3/4	1.75	1 1/16	5.0		
16 JX6	1	2.00	1 3/16	4.0		

### S6X

Swivel Nut Branch Tee  
37° Flare / 37° Flare / 37° Swivel

SAE 070433  
HPD Base # 393T

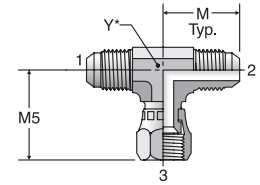

Y\* – Across wrench flats

TUBE FITTING PART #	END SIZE (in.)	M (in.)	M5 (in.)	Y (in.)	STANDARD Dynamic Pressure (x 1,000 PSI)		
					-S	-SS	-B
4 S6X	1/4	0.89	1.00	7/16	7.5	7.7	
5 S6X	5/16	0.95	1.16	9/16	6.0	6.0	
6 S6X	3/8	1.06	1.25	9/16	6.0	6.0	
8 S6X	1/2	1.25	1.38	3/4	6.0	6.0	
10 S6X	5/8	1.45	1.62	7/8	5.0	5.0	
12 S6X	3/4	1.66	1.75	1 1/16	5.0	5.0	
14 S6X	7/8	1.80	1.91	1 5/16	5.0		
16 S6X	1	1.81	2.00	1 5/16	4.0	2.5	
20 S6X	1 1/4	2.06	2.31	1 5/8	4.0	2.5	
24 S6X	1 1/2	2.33	2.67	1 7/8	3.0	2.0	

### R6X

Swivel Nut Run Tee  
37° Flare / 37° Swivel / 37° Flare

SAE 070432  
HPD Base # 063T

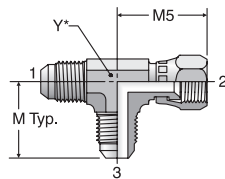

Y\* – Across wrench flats

TUBE FITTING PART #	END SIZE (in.)	M (in.)	M5 (in.)	Y (in.)	STANDARD Dynamic Pressure (x 1,000 PSI)		
					-S	-SS	-B
4 R6X	1/4	0.89	1.00	7/16	7.5	7.7	
5 R6X	5/16	0.95	1.16	9/16	6.0	6.0	
6 R6X	3/8	1.06	1.25	9/16	6.0	6.0	
8 R6X	1/2	1.25	1.38	3/4	6.0	6.0	
10 R6X	5/8	1.45	1.62	7/8	5.0	5.0	
12 R6X	3/4	1.66	1.75	1 1/16	5.0	5.0	
14 R6X	7/8	1.80	1.91	1 5/16	5.0		
16 R6X	1	1.81	2.00	1 5/16	4.0	2.5	
20 R6X	1 1/4	2.06	2.31	1 5/8	4.0	2.5	
24 R6X	1 1/2	2.33	2.59	1 7/8	3.0	2.0	

Dimensions and pressures for reference only, subject to change.

# S50X

Straight Thread Branch Tee  
 37° Flare / 37° Flare /  
 SAE-ORB

SAE 070429  
 HPD Base # 253T

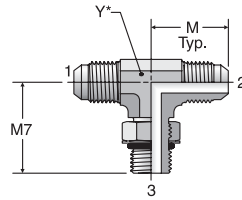

Y\* – Across wrench flats

TUBE FITTING PART #	END SIZE			M (in.)	M7 (in.)	Y (in.)	STANDARD Dynamic Pressure (x 1,000 PSI)		
	1 (in.)	2 (in.)	3 UN/UNF-2A				-S	-SS	-B
	4 S50X	1/4	1/4				7/16-20	0.89	1.03
4-4-6 S50X	1/4	1/4	9/16-18	1.05	1.25	9/16	6.0		
5 S50X	5/16	5/16	1/2-20	0.97	1.13	9/16	6.0		
6 S50X	3/8	3/8	9/16-18	1.06	1.25	9/16	6.0	5.4	
6-6-8 S50X	3/8	3/8	3/4-16	1.14	1.45	3/4	6.0		
8 S50X	1/2	1/2	3/4-16	1.25	1.45	3/4	6.0	5.4	
8-8-10 S50X	1/2	1/2	7/8-14	1.33	1.70	7/8	5.0		
10 S50X	5/8	5/8	7/8-14	1.45	1.70	7/8	5.0		
10-10-12 S50X	5/8	5/8	1 1/16-12	1.54	1.94	1 1/16	5.0		
12 S50X	3/4	3/4	1 1/16-12	1.66	1.94	1 1/16	5.0	5.4	
12-12-16 S50X	3/4	3/4	1 5/16-12	1.77	2.05	1 5/16	4.0		
16 S50X	1	1	1 5/16-12	1.81	2.05	1 5/16	4.0	3.0	
20 S50X	1 1/4	1 1/4	1 5/8-12	2.06	2.25	1 5/8	4.0		
24 S50X	1 1/2	1 1/2	1 7/8-12	2.33	2.39	1 7/8	3.0		
32 S50X	2	2	2 1/2-12	3.06	2.89	2.50	2.0		

# R50X

Straight Thread Run Tee  
 37° Flare / SAE-ORB /  
 37° Flare

SAE 070428  
 HPD Base # 053T

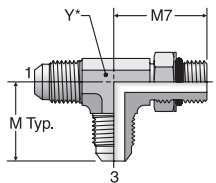

Y\* – Across wrench flats

TUBE FITTING PART #	END SIZE			M (in.)	M7 (in.)	Y (in.)	STANDARD Dynamic Pressure (x 1,000 PSI)		
	1 (in.)	2 UN/UNF-2A	3 (in.)				-S	-SS	-B
	4 R50X	1/4	7/16-20				1/4	0.89	1.03
4-6-4 R50X	1/4	9/16-18	1/4	1.00	1.25	9/16	6.0	6.0	
5 R50X	5/16	1/2-20	5/16	0.97	1.13	9/16	6.0		
6 R50X	3/8	9/16-18	3/8	1.06	1.25	9/16	6.0	5.4	
6-8-6 R50X	3/8	3/4-16	3/8	1.14	1.45	3/4	6.0		
8 R50X	1/2	3/4-16	1/2	1.25	1.45	3/4	6.0	5.4	
8-6-8 R50X	1/2	9/16-18	1/2	1.25	1.33	3/4		5.4	
8-10-8 R50X	1/2	7/8-14	1/2	1.33	1.70	7/8	5.0		
8-12-8 R50X	1/2	1 1/16-12	1/2	1.42	1.94	1 1/16		5.4	
10 R50X	5/8	7/8-14	5/8	1.45	1.70	7/8	5.0	5.4	
10-12-10 R50X	5/8	1 1/16-12	5/8	1.53	1.94	1 1/16	5.0		
12 R50X	3/4	1 1/16-12	3/4	1.66	1.94	1 1/16	5.0	5.4	
12-16-12 R50X	3/4	1 5/16-12	3/4	1.76	2.05	1 5/16	4.0		
16 R50X	1	1 5/16-12	1	1.81	2.05	1 5/16	4.0	3.0	
20 R50X	1 1/4	1 5/8-12	1 1/4	2.06	2.25	1 5/8	4.0	2.5	
24 R50X	1 1/2	1 7/8-12	1 1/2	2.33	2.39	1 7/8	3.0		
32 R50X	2	2 1/2-12	2	3.06	2.89	2 1/2	2.0		

Dimensions and pressures for reference only, subject to change.

# STX

Male Branch Tee  
37° Flare / 37° Flare / NPTF

SAE 070425  
HPD Base # 213T

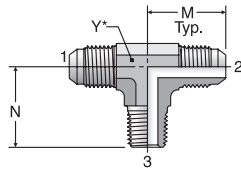

Y\* – Across wrench flats

TUBE FITTING PART #	END SIZE		M (in.)	N (in.)	Y (in.)	STANDARD Dynamic Pressure (x 1,000 PSI)		
	1 & 2 (in.)	3 NPTF				-S	-SS	-B
3 STX	3/16	1/8-27	0.83	0.72	7/16	6.0		
4 STX	1/4	1/8-27	0.89	0.78	7/16	6.0	6.0	3.3
4-4-4 STX	1/4	1/4-18	1.05	1.09	9/16	6.0	6.0	3.3
4-4-6 STX	1/4	3/8-18	1.13	1.22	3/4		6.0	
5 STX	5/16	1/8-27	0.95	0.78	9/16	6.0	6.0	3.3
5-5-4 STX	5/16	1/4-18	1.05	1.09	9/16	6.0	6.0	
6 STX	3/8	1/4-18	1.06	1.09	9/16	6.0	6.0	3.3
6-6-6 STX	3/8	3/8-18	1.14	1.22	3/4	6.0	6.0	
8 STX	1/2	3/8-18	1.25	1.22	3/4	6.0	6.0	3.3
8-8-8 STX	1/2	1/2-14	1.34	1.47	7/8	6.0	6.0	
10 STX	5/8	1/2-14	1.45	1.47	7/8	5.0	5.0	3.3
12 STX	3/4	3/4-14	1.66	1.59	1 1/16	4.0	4.0	
14 STX	7/8	3/4-14	1.80	1.69	1 5/16	4.0		
16 STX	1	1-11 1/2	1.81	1.97	1 5/16	3.0	3.0	
20 STX	1 1/4	1 1/4-11 1/2	2.06	2.38	1 5/8	2.5	2.5	
24 STX	1 1/2	1 1/2-11 1/2	1.33	2.64	1 7/8	2.5	2.5	

# RTX

Male Run Tee  
37° Flare / NPTF / 37° Flare

SAE 070424  
HPD Base # 013T

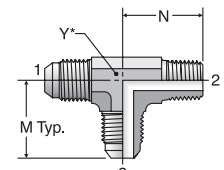

Y\* – Across wrench flats

TUBE FITTING PART #	END SIZE		M (in.)	N (in.)	Y (in.)	STANDARD Dynamic Pressure (x 1,000 PSI)		
	1 & 2 (in.)	3 NPTF				-S	-SS	-B
3 RTX	3/16	1/8-27	0.83	0.72	7/16	6.0	6.0	3.3
4 RTX	1/4	1/8-27	0.89	0.78	7/16	6.0	6.0	3.3
4-4-4 RTX	1/4	1/4-18	1.05	1.09	9/16	6.0	6.0	
5 RTX	5/16	1/8-27	0.97	0.81	9/16	6.0	6.0	3.3
5-4-5 RTX	5/16	1/4-18	1.05	1.09	9/16		6.0	
6 RTX	3/8	1/4-18	1.06	1.09	9/16	6.0	6.0	3.3
6-6-6 RTX	3/8	3/8-18	1.14	1.22	3/4	6.0	6.0	
8 RTX	1/2	3/8-18	1.25	1.22	3/4	6.0	6.0	3.3
8-8-8 RTX	1/2	1/2-14	1.34	1.47	7/8	6.0	6.0	
10 RTX	5/8	1/2-14	1.45	1.47	7/8	5.0	5.0	
12 RTX	3/4	3/4-14	1.66	1.59	1 1/16	4.0	4.0	
12-8-12 RTX	3/4	1/2-14	1.66	1.59	1 1/16		5.0	
14 RTX	7/8	3/4-14	1.80	1.69	1 5/16	4.0		
16 RTX	1	1-11 1/2	1.81	1.97	1 5/16	3.0	3.0	
20 RTX	1 1/4	1 1/4-11 1/2	2.06	2.38	1 5/8	2.5	2.5	
24 RTX	1 1/2	1 1/2-11 1/2	2.33	2.64	1 7/8	2.5	2.5	

# OTX

Female Branch Tee  
37° Flare / 37° Flare / NPTF

SAE 070427  
HPD Base # 223T

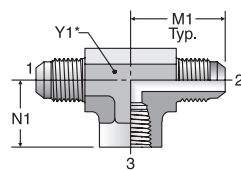

Y\* – Across wrench flats

TUBE FITTING PART #	END SIZE		M1 (in.)	N1 (in.)	Y1 (in.)	STANDARD Dynamic Pressure (x 1,000 PSI)		
	1 & 2 (in.)	3 NPTF				-S	-SS	-B
4 OTX	1/4	1/8-27	1.08	0.66	9/16	5.0	5.0	3.3
4-4-4 OTX	1/4	1/4-18	1.13	0.88	3/4		5.0	
5 OTX	5/16	1/8-27	1.08	0.66	9/16	5.0		
6 OTX	3/8	1/4-18	1.24	0.88	3/4	5.0	5.0	3.3
6-6-6 OTX	3/8	3/8-18	1.23	1.02	7/8	4.5	4.5	
8 OTX	1/2	3/8-18	1.42	1.02	7/8	4.5	4.5	2.9
8-8-8 OTX	1/2	1/2-14	1.42	1.23	1 1/16	3.0	3.0	
10 OTX	5/8	1/2-14	1.64	1.24	1 1/16	3.0	3.0	
12 OTX	3/4	3/4-14	1.89	1.36	1 5/16	3.0	3.0	2.0
14 OTX	7/8	3/4-14	1.86	1.42	1 5/16	3.0		
16 OTX	1	1-11 1/2	2.17	1.63	1 5/8	1.8	1.2	
20 OTX	1 1/4	1 1/4-11 1/2	2.33	1.70	1 7/8	1.5		
24 OTX	1 1/2	1 1/2-11 1/2	2.89	2.08	2 1/2	1.5		

# MTX

Female Run Tee  
37° Flare / NPTF / 37° Flare

SAE 070426  
HPD Base # 023T

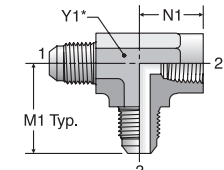

Y\* – Across wrench flats

TUBE FITTING PART #	END SIZE		M1 (in.)	N1 (in.)	Y1 (in.)	STANDARD Dynamic Pressure (x 1,000 PSI)		
	1 & 3 (in.)	2 NPTF				-S	-SS	-B
4 MTX	1/4	1/8-27	1.08	0.66	9/16	5.0	5.0	3.3
4-4-4 MTX	1/4	1/4-18	1.13	0.88	3/4		5.0	
6 MTX	3/8	1/4-18	1.24	0.88	3/4	5.0	5.0	3.3
8 MTX	1/2	3/8-18	1.42	1.02	7/8	4.5	4.5	2.9
8-8-8 MTX	1/2	1/2-14	1.42	1.23	1 1/16	3.0	3.0	
10 MTX	5/8	1/2-14	1.64	1.24	1 1/16	3.0		
12 MTX	3/4	3/4-14	1.89	1.36	1 5/16	3.0	3.0	
14 MTX	7/8	3/4-14	1.86	1.42	1 5/16	3.0		
16 MTX	1	1-11 1/2	2.17	1.63	1 5/8	1.8		
20 MTX	1 1/4	1 1/4-11 1/2	2.33	1.70	1 7/8	1.5		
24 MTX	1 1/2	1 1/2-11 1/2	2.89	2.08	2 1/2	1.5		

Dimensions and pressures for reference only, subject to change.



# S870MX

ISO 6149 Branch Tee  
37° Flare / 37° Flare / ISO 6149

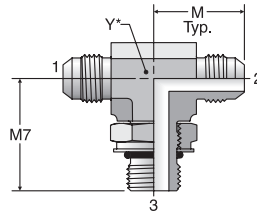

Y\* – Across wrench flats

TUBE FITTING PART #	END SIZE			M (mm)	M7 (mm)	Y (mm)	STANDARD Dynamic Pressure (x 1,000 PSI)		
	1 & 2		3				-S	-SS	-B
	(mm)	(in.)	Male Metric Parallel Thread						
6M14S870MX	10	3/8	M14 x 1.5	26.9	33.5	14	6.0		
8M16S870MX	12	1/2	M16 x 1.5	31.8	38.0	19			
10M22S870MX	14,15,16	5/8	M22 x 1.5	36.8	42.5	22			
12M27S870MX	18,20	3/4	M27 x 2	42.2	51.0	27			

# R870MX

ISO 6149 Run Tee  
37° Flare / ISO 6149 / 37° Flare

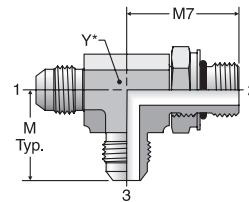

Y\* – Across wrench flats

TUBE FITTING PART #	END SIZE			M (mm)	M7 (mm)	Y (mm)	STANDARD Dynamic Pressure (x 1,000 PSI)		
	1 & 3		2				-S	-SS	-B
	(mm)	(in.)	Male Metric Parallel Thread						
6M14R870MX	10	3/8	M14 x 1.5	26.9	33.5	14	5.0		
8M16R870MX	12	1/2	M16 x 1.5	31.8	38.0	19			
10M22R870MX	14,15,16	5/8	M22 x 1.5	36.8	42.5	22	5.0		
12M27R870MX	18,20	3/4	M27 x 2	42.2	51	27	5.0		

# S40MX

Male Branch Tee – BSPP  
37° Flare / 37° Flare / BSPP-ORR

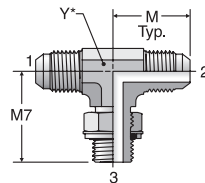

Y\* – Across wrench flats

# R40MX

Male Run Tee – BSPP  
37° Flare / BSPP-ORR / 37° Flare

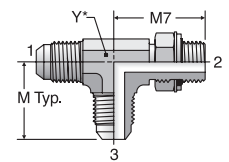

Y\* – Across wrench flats

TUBE FITTING PART #	END SIZE			M (mm)	M7 (mm)	Y (mm)	STANDARD Dynamic Pressure (x 1,000 PSI)		
	1 & 2		3				-S	-SS	-B
	(mm)	(in.)	BSPP						
4S40MX	6	1/4	1/8-28	22.6	26.2	11	3.6		
6S40MX	10	3/8	1/4-19	26.9	31.8	14	3.6		
8S40MX	12	1/2	3/8-19	31.8	36.8	19	3.6		
10S40MX	14,15,16	5/8	1/2-14	36.8	43.2	22	3.6		
12S40MX	18,20	3/4	3/4-14	42.2	49.3	27	3.6		
16S40MX	25	1	1-11	46.0	52.1	33	3.6		

TUBE FITTING PART #	END SIZE			M (mm)	M7 (mm)	Y (mm)	STANDARD Dynamic Pressure (x 1,000 PSI)		
	1 & 3		2				-S	-SS	-B
	(mm)	(in.)	BSPP						
4R40MX	6	1/4	1/8-28	22.6	26.2	11	3.6		
6R40MX	10	3/8	1/4-19	26.9	31.8	14	3.6		
8R40MX	12	1/2	3/8-19	31.8	36.8	19	3.6		
10R40MX	14,15,16	5/8	1/2-14	36.8	43.2	22	3.6		
12R40MX	18,20	3/4	3/4-14	42.2	49.3	27	3.6		
16R40MX	25	1	1-11	46.0	52.1	33	3.6		
20R40MX	28, 30, 32	1 1/4	1 1/4-11	52.3	57.2	41	3.0		

Dimensions and pressures for reference only, subject to change.



### KTX

Union Cross  
37° Flare (all four ends)

SAE 070501  
HPD Base # 033X

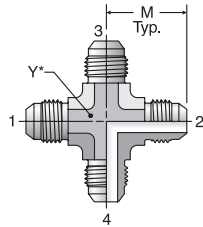

Y\* – Across wrench flats

TUBE FITTING PART #	END SIZE	M (in.)	Y (in.)	STANDARD Dynamic Pressure (x 1,000 PSI)		
				-S	-SS	-B
	1-4 (in.)					
4 KTX	1/4	0.89	7/16	7.5	7.7	3.3
5 KTX	5/16	0.95	9/16	6.0		
6 KTX	3/8	1.06	9/16	6.0	6.0	3.3
8 KTX	1/2	1.25	3/4	6.0	6.0	3.3
10 KTX	5/8	1.45	7/8	5.0		
12 KTX	3/4	1.66	1 1/16	5.0	5.0	
16 KTX	1	1.81	1 5/16	4.0		

### PNTX

Plug  
37° Flare

SAE 070109  
HPD Base # 03CP

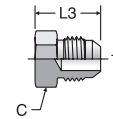

TUBE FITTING PART #	END SIZE	C HEX (in.)	L3 (in.)	STANDARD Dynamic Pressure (x 1,000 PSI)		
				-S	-SS	-B
	1 (in.)					
2 PNTX	1/8	7/16	0.70		9.0	
3 PNTX	3/16	7/16	0.73	7.5	9.0	
4 PNTX	1/4	1/2	0.80	7.5	9.0	3.3
5 PNTX	5/16	9/16	0.80	6.0	7.2	3.3
6 PNTX	3/8	5/8	0.84	6.0	7.2	3.3
8 PNTX	1/2	13/16	0.94	6.0	7.2	3.3
10 PNTX	5/8	15/16	1.10	5.0	6.0	3.3
12 PNTX	3/4	1 1/8	1.28	5.0	6.0	3.3
14 PNTX	7/8	1 1/4	1.31	5.0	5.0	
16 PNTX	1	1 3/8	1.33	4.5	5.4	
20 PNTX	1 1/4	1 11/16	1.45	4.0	4.8	
24 PNTX	1 1/2	2	1.66	4.0	4.8	
32 PNTX	2	2 5/8	2.05	2.0	2.4	

### FNTX

Cap  
37° Flare

SAE 070112  
HPD Base # 06CP

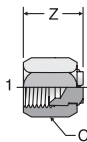

TUBE FITTING PART #	END SIZE	C HEX (in.)	Z (in.)	STANDARD Dynamic Pressure (x 1,000 PSI)		
				-S	-SS	-B
	1 (in.)					
2 FNTX	1/8	3/8	0.60	7.5	9.0	3.3
3 FNTX	3/16	7/16	0.66	7.5	9.0	3.3
4 FNTX	1/4	9/16	0.67	7.5	9.0	3.3
5 FNTX	5/16	5/8	0.77	6.0	7.2	3.3
6 FNTX	3/8	11/16	0.81	6.0	7.2	3.3
8 FNTX	1/2	7/8	0.94	6.0	7.2	3.3
10 FNTX	5/8	1	1.07	5.0	6.0	3.3
12 FNTX	3/4	1 1/4	1.24	5.0	6.0	3.3
14 FNTX	7/8	1 3/8	1.26	5.0		
16 FNTX	1	1 1/2	1.29	4.5	5.4	2.6
20 FNTX	1 1/4	2	1.39	4.0	4.8	
24 FNTX	1 1/2	2 1/4	1.70	4.0	4.8	
32 FNTX	2	2 7/8	2.01	2.0	2.4	

### T22X

Mountie Cap

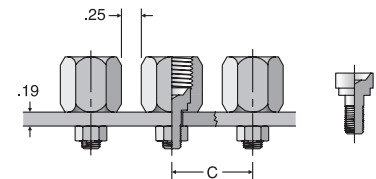

TUBE FITTING PART #	END SIZE		C (in.)	L (in.)	STANDARD Dynamic Pressure (x 1,000 PSI)		
	1 (in.)	2 UNC/UNF-2A			-S	-SS	-B
4 T22X	1/4	1/4-20	0.91	0.72	7.5		
6 T22X	3/8	1/4-20	1.08	0.81	6.0		
8 T22X	1/2	5/16-18	1.25	0.97	6.0		

Dimensions and pressures for reference only, subject to change.

### HTXO

Union  
37° Flare

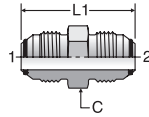

TUBE FITTING PART #	END SIZE		C HEX (in.)	L1 (in.)	STANDARD Dynamic Pressure (x 1,000 PSI) -SS
	1 & 2 (in.)				
4 HTXO	1/4	1/2	5/8	1.39	9.0
6 HTXO	3/8	5/8	1 1/8	1.42	7.7
8 HTXO	1/2	13/16	1 3/8	1.66	7.7
10 HTXO	5/8	15/16	1 7/8	1.98	6.0
12 HTXO	3/4	1 1/8	2 1/8	2.24	6.0
16 HTXO	1	1 3/8	2 3/4	2.41	5.4
20 HTXO	1 1/4	1 11/16	3 1/8	2.58	5.0
24 HTXO	1 1/2	2	3 3/4	2.90	5.0

### F5OXO

Straight Thread Connector  
37° Flare / SAE-ORB

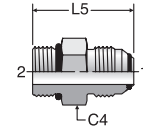

TUBE FITTING PART #	END SIZE		C4 HEX (in.)	L5 (in.)	STANDARD Dynamic Pressure (x 1,000 PSI) -SS
	1 (in.)	2			
	(in.)	UN/UNF-2A			
4 F5OXO	1/4	7/16-20	9/16	1.23	9.0
4-6 F5OXO	1/4	9/16-18	11/16	1.28	7.7
6 F5OXO	3/8	9/16-18	11/16	1.30	7.7
6-4 F5OXO	3/8	7/16-20	5/8	1.27	7.7
6-8 F5OXO	3/8	3/4-16	7/8	1.38	7.7
8 F5OXO	1/2	3/4-16	7/8	1.48	7.7
8-6 F5OXO	1/2	9/16-18	13/16	1.44	7.7
10 F5OXO	5/8	7/8-14	1	1.75	6.0
12 F5OXO	3/4	1 1/16-12	1 1/4	1.97	6.0
16 F5OXO	1	1 5/16-12	1 1/2	2.05	5.4
20 F5OXO	1 1/4	1 5/8-12	1 7/8	2.17	5.0
24 F5OXO	1 1/2	1 7/8-12	2 1/8	2.37	4.0
32 F5OXO	2	2 1/2-12	2 3/4	2.78	2.4

### FTXO

Male Connector  
37° Flare / NPTF

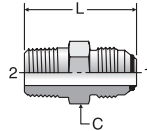

TUBE FITTING PART #	END SIZE		C HEX (in.)	L (in.)	STANDARD Dynamic Pressure (x 1,000 PSI) -SS
	1 (in.)	2 NPTF			
4 FTXO	1/4	1/8-27	1/2	1.23	6.0
4-4 FTXO	1/4	1/4-18	9/16	1.43	6.0
6 FTXO	3/8	1/4-18	5/8	1.45	6.0
6-6 FTXO	3/8	3/8-18	3/4	1.46	6.0
8 FTXO	1/2	3/8-18	13/16	1.53	6.0
8-8 FTXO	1/2	1/2-14	7/8	1.78	6.0
10 FTXO	5/8	1/2-14	15/16	1.94	5.0
12 FTXO	3/4	3/4-14	1 1/8	2.10	5.0
16 FTXO	1	1-11 1/2	1 3/8	2.38	4.5
20 FTXO	1 1/4	1 1/4-11 1/2	1 11/16	2.52	3.0
24 FTXO	1 1/2	1 1/2-11 1/2	2	2.76	3.0
32 FTXO	2	2-11 1/2	2 5/8	3.18	2.0

### GTXO

Female Connector  
37° Flare / NPTF

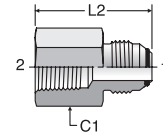

TUBE FITTING PART #	END SIZE		C1 HEX (in.)	L2 (in.)	STANDARD Dynamic Pressure (x 1,000 PSI) -SS
	1 (in.)	2 NPTF			
4 GTXO	1/4	1/8-27	9/16	1.20	6.0
6 GTXO	3/8	1/4-18	3/4	1.41	6.0
8 GTXO	1/2	3/8-18	7/8	1.58	6.0
10 GTXO	5/8	1/2-14	1 1/8	1.94	5.0
12 GTXO	3/4	3/4-14	1 3/8	2.10	4.8
16 GTXO	1	1-11 1/2	1 5/8	2.43	3.6
20 GTXO	1 1/4	1 1/4-11 1/2	2	2.56	3.0
24 GTXO	1 1/2	1 1/2-11 1/2	2 3/8	2.70	2.4

Dimensions and pressures for reference only, subject to change.

### ETXO

Union Elbow  
37° Flare / 37° Flare

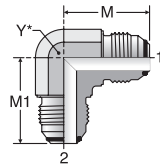

TUBE FITTING PART #	END SIZE		M (in.)	M1 (in.)	Y (in.)	STANDARD Dynamic Pressure (x 1,000 PSI) -SS
	1 & 2 (in.)					
4 ETXO	1/4		0.90	0.90	7/16	7.7
6 ETXO	3/8		1.08	1.08	9/16	6.0
8 ETXO	1/2		1.25	1.25	3/4	6.0
10 ETXO	5/8		1.50	1.50	7/8	5.0
12 ETXO	3/4		1.70	1.70	1 1/16	5.0
16 ETXO	1		1.89	1.89	1 5/16	5.0
20 ETXO	1 1/4		2.13	2.13	1 5/8	5.0
24 ETXO	1 1/2		2.41	2.41	1 7/8	5.0

### C6XO

Swivel Nut Elbow  
37° Flare / 37° Swivel

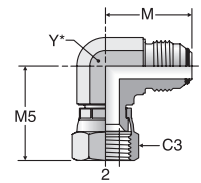

TUBE FITTING PART #	END SIZE		C3 (in.)	M (in.)	M5 (in.)	M10 (in.)	Y (in.)	STANDARD Dynamic Pressure (x 1,000 PSI) -SS
	1 & 2 (in.)	HEX (in.)						
4 C6XO	1/4		9/16	0.90	1.00	0.66	7/16	7.7
6 C6XO	3/8		11/16	1.08	1.25	0.88	9/16	6.0
8 C6XO	1/2		7/8	1.25	1.38	0.95	3/4	6.0
10 C6XO	5/8		1	1.50	1.62	1.13	7/8	5.0
12 C6XO	3/4		1 1/4	1.70	1.75	1.19	1 1/16	5.0
16 C6XO	1		1 1/2	1.89	2.00	1.41	1 5/16	2.5
20 C6XO	1 1/4		2	2.13	2.31	1.69	1 5/8	2.5

### CTXO

Male Elbow  
37° Flare / NPTF

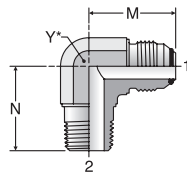

TUBE FITTING PART #	END SIZE		M (in.)	N (in.)	Y (in.)	STANDARD Dynamic Pressure (x 1,000 PSI) -SS
	1 (in.)	2 NPTF				
4 CTXO	1/4	1/8-27	0.90	0.78	7/16	6.0
4-4 CTXO	1/4	1/4-18	1.06	1.09	9/16	6.0
6 CTXO	3/8	1/4-18	1.08	1.09	9/16	6.0
6-6 CTXO	3/8	3/8-18	1.16	1.22	3/4	6.0
8 CTXO	1/2	3/8-18	1.25	1.22	3/4	6.0
8-8 CTXO	1/2	1/2-14	1.33	1.47	7/8	6.0
10 CTXO	5/8	1/2-14	1.51	1.47	7/8	5.0
12 CTXO	3/4	3/4-14	1.70	1.59	1 1/16	4.0
16 CTXO	1	1-11 1/2	1.89	1.97	1 5/16	3.0
20 CTXO	1 1/4	1 1/4-11 1/2	2.13	2.38	1 5/8	2.5
24 CTXO	1 1/2	1 1/2-11 1/2	2.41	2.64	1 7/8	2.5
32 CTXO	2	2-11 1/2	3.13	3.00	2 1/2	2.0

### C5OXO

Straight Thread Elbow  
37° Flare / SAE-ORB

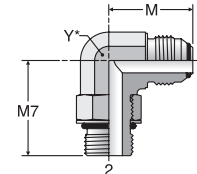

TUBE FITTING PART #	END SIZE		M (in.)	M7 (in.)	Y (in.)	STANDARD Dynamic Pressure (x 1,000 PSI) -SS
	1 (in.)	2 UN/UNF-2A				
4 C5OXO	1/4	7/16-20	0.90	1.03	7/16	6.0
6 C5OXO	3/8	9/16-18	1.08	1.25	9/16	5.4
8 C5OXO	1/2	3/4-16	1.25	1.45	3/4	5.4
10 C5OXO	5/8	7/8-14	1.50	1.70	7/8	5.4
12 C5OXO	3/4	1 1/16-12	1.70	1.94	1 1/16	5.4
16 C5OXO	1	1 5/16-12	1.89	2.05	1 5/16	3.7
20 C5OXO	1 1/4	1 5/8-12	2.13	2.25	1 5/8	2.8
24 C5OXO	1 1/2	1 7/8-12	2.41	2.39	1 7/8	2.5
32 C5OXO	2	2 1/2-12	3.13	2.89	2 1/2	1.5

Dimensions and pressures for reference only, subject to change.

### JTXO

Union Tee  
37° Flare (all three ends)

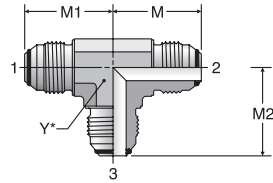

TUBE FITTING PART #	END SIZE		M (in.)	M1 (in.)	M2 (in.)	Y (in.)	STANDARD Dynamic Pressure (x 1,000 PSI) -SS
	1 - 3 (in.)						
4 JTXO	1/4		0.90	0.90	0.90	7/16	7.7
6 JTXO	3/8		1.08	1.08	1.08	9/16	6.0
8 JTXO	1/2		1.25	1.25	1.25	3/4	6.0
10 JTXO	5/8		1.50	1.50	1.50	7/8	5.0
12 JTXO	3/4		1.70	1.70	1.70	1 1/16	5.0
16 JTXO	1		1.89	1.89	1.89	1 5/16	5.0
20 JTXO	1 1/4		2.13	2.13	2.13	1 5/8	5.0
24 JTXO	1 1/2		2.41	2.41	2.41	1 7/8	5.0

### RTXO

Male Run Tee  
37° Flare / NPTF / 37° Flare

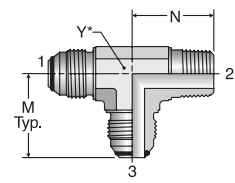

TUBE FITTING PART #	END SIZE		M (in.)	N (in.)	Y (in.)	STANDARD Dynamic Pressure (x 1,000 PSI) -SS
	1 & 3 (in.)	2 NPTF				
4 RTXO	1/4	1/8-27	0.90	0.78	7/16	6.0
6 RTXO	3/8	1/4-18	1.08	1.09	9/16	6.0
8 RTXO	1/2	3/8-18	1.25	1.22	3/4	6.0
10 RTXO	5/8	1/2-14	1.51	1.47	7/8	5.0
12 RTXO	3/4	3/4-14	1.70	1.59	1 1/16	4.0
16 RTXO	1	1-11 1/2	1.89	1.97	1 5/16	3.0
20 RTXO	1 1/4	1 1/4-11 1/2	2.13	2.38	1 5/8	2.5
24 RTXO	1 1/2	1 1/2-11 1/2	2.41	2.64	1 7/8	2.5

### R5OXO

Straight Thread Run Tee  
37° Flare / SAE-ORB / 37° Flare

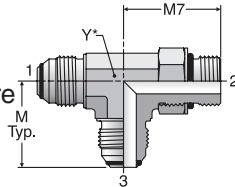

TUBE FITTING PART #	END SIZE		M (in.)	M7 (in.)	Y (in.)	STANDARD Dynamic Pressure (x 1,000 PSI) -SS
	1 (in.)	2 UN/UNF-2A				
4 R5OXO	1/4	7/16-20	0.90	1.03	7/16	6.0
6 R5OXO	3/8	9/16-18	1.08	1.25	9/16	5.4
8 R5OXO	1/2	3/4-16	1.25	1.45	3/4	5.4
10 R5OXO	5/8	7/8-14	1.51	1.70	7/8	5.4
12 R5OXO	3/4	1 1/16-12	1.70	1.94	1 1/16	5.4
16 R5OXO	1	1 5/16-12	1.89	2.05	1 5/16	3.7
20 R5OXO	1 1/4	1 5/8-12	2.13	2.25	1 5/8	2.8

Dimensions and pressures for reference only, subject to change.