

# ASHCROFT®

## Refrigerant Ammonia Gauges

- *Improved design*
- *Patented PowerFlex™ movement*
- *Temperature indication*
- *Two year warranty*

The Ashcroft refrigerant ammonia gauge is ideally suited for refrigeration applications.

An improved design utilizes a stainless steel Bourdon tube soldered to a plated steel socket. The patented PowerFlex™ movement and state-of-the-art manufacturing processes provide superior gauge performance and extended gauge life.

A mass spectrometer leak test ensures leak integrity to  $1 \times 10^{-4}$  cc per second of Helium at rated pressure.

Dials include equivalent ammonia temperature scales.

### The PowerFlex™ Movement

The patented PowerFlex™ movement addresses problems common to conventional movement designs. The unique suspended construction isolates the gauge movement from the socket, which is the normal travel path for shock and vibration. In this design, the Bourdon tube and linkwire cushion the movement under stress conditions, reducing wear on the lubricated surfaces.



**ISO 9001**  
REGISTERED FIRM

**DRESSER** INSTRUMENT

BULLETIN CRG-2

A Halliburton Company

### Product Specifications

**Ashcroft**  
**Model Number:** 1005M XR5  
**Size:** 2 1/2", 3 1/2" Diameter  
**Case:** Black painted steel  
**Window:** Polycarbonate  
**Dial:** Steel, white background, black pressure scale, red temperature scale  
**Pointer:** Black, Aluminum  
**Movement:** Patented PowerFlex, stainless steel with polyester segment  
**Bourdon Tube:** 316 stainless steel  
**Socket:** Steel  
**Restrictor:** .020" Orifice throttle plug, stainless steel  
**Connection:** 1/4" NPT Lower  
**Construction:** Soldered Tube/Socket and Tube/Tip Joints  
**Accuracy:** ASME B40.1, Grade B (±3-2-3%)  
**Ranges:** 30" HG VAC/0/150 psi, 30" HG VAC/0/300 psi with equivalent ammonia temperature scales

#### OPTIONAL FEATURES

**Case:** Stainless-clad Aluminum (Type 1005SM) (ABS 1005PM)  
**Window:** Glass with black ring (XRG) Glass with stainless steel cladding (XSC)  
**Dial:** Aluminum material Customized artwork Metric ranges  
**Other:** Bulk packaging FlutterGuard™ (XSF)

### Dimensions

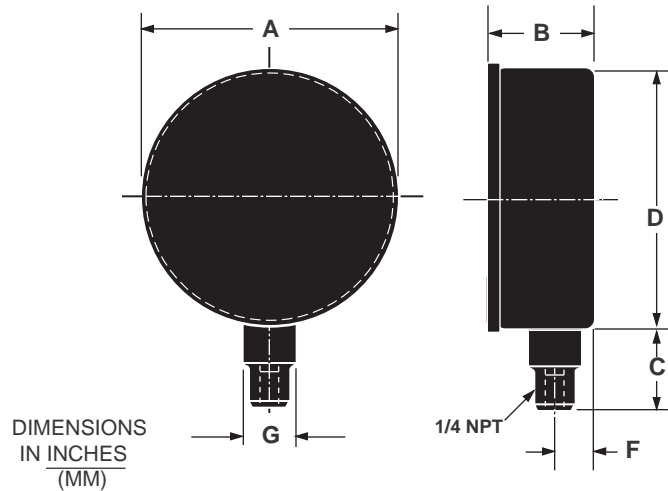

SIZE/TYPE	A	B	C	D	F	G
2 1/2"-W1005M XR5	2.73 (69)	1.10 (28)	.82 (21)	2.68 (68)	.36 (9)	.56 (14)
3 1/2"-W1005M XR5	3.67 (93)	1.12 (28)	.92 (23)	3.61 (92)	.43 (11)	.56 (14)

### Ordering Information

25 W 1005 M 02L XR5 150#IV  
 Dial Size: 2 1/2"  
 Patented PowerFlex™ Movement  
 Case Type Number: 1005  
 Socket Material: Steel  
 Connection Size/Location: 1/4 NPT Lower  
 Service: (Refrigerant, Ammonia)  
 Range: 30" HG VAC/0/150 psi

#### U.S. Headquarters

**Berea, Kentucky**  
 Harrison Road  
 Berea, KY 40403  
 Tel: (606) 986-9333  
 FAX: 1-800-28 BEREA  
 (1-800-282-3732)

#### International Headquarters

**Stratford, Connecticut**  
 250 E. Main Street  
 Stratford, CT 06614-5145  
 Tel: (203) 378-8281  
 FAX: (203) 385-0499

#### U.S. Sales Offices

**Chicago, Illinois**  
 400 W. Lake Street  
 Suite 318  
 Roselle, IL 60172-3573  
 Tel: (630) 980-9030  
 FAX: (630) 980-9440

#### Houston, Texas

3838 North Sam Houston  
 Parkway East  
 Suite 120  
 Houston, TX 77032  
 Tel: (281) 590-1092  
 FAX: (281) 590-7100

#### Los Angeles, California

3931 MacArthur Blvd.  
 Suite 202  
 Newport Beach, CA 92660  
 Tel: (714) 852-8948  
 FAX: (714) 852-8971

#### Hartford, Connecticut

1501 East Main Street  
 Meriden, CT 06450-2860  
 Tel: (203) 235-0450  
 FAX: (203) 235-0593

#### Mobile, Alabama

851 South Beltline Hwy.  
 Suite 402, 4th Floor  
 Mobile, AL 36606  
 Tel: (334) 473-1692  
 FAX: (334) 473-1782

visit our web site at  
[www.dresser.com/instruments](http://www.dresser.com/instruments)